

- Economic plastic housing, light weight;
- Preventing oil and water ;
- Double way switch, double spring inner switch;
- Variety of levers;
- Widely used in Mechanical equipment, automatic machine, and instrument, electro motion tool etc.

### Model & Meanings

X Z - 9 101



### Contact Form & Mounting Holes Dimensions

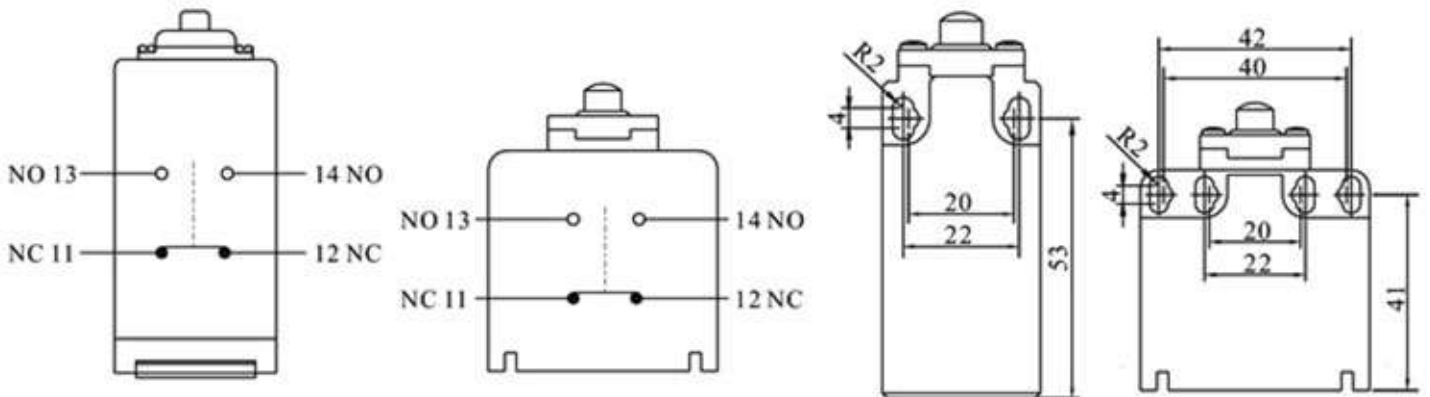

## Specification

项目 Item		参数值 Data
额定负荷 Rating load		10(4)A/250VAC,6(2)A 380VAC
操作速度 Operation speed		5mm-0.5m/s
操作频率 Operation frequency	机械 Mechanical	120次/分 120times/min
	电气 Electrical	30次/分 30times/min
绝缘电阻 Insulation resistance		100mΩ以上(Above) DC500V
绝缘电阻 Contact resistance		25mΩ初值 initial value)
介质耐压 Withstand voltage	非连线 Non-connection wire	1000VAC
	各端子间 Every terminal	1500VAC
振动 Vibration	误动作 Misoperation	10-55Hz Amplitude (复振幅) 1.5mm
冲击 Impact	耐久 Durable	1000m/s <sup>2</sup>
	误动作 Misoperation	300m/s <sup>2</sup>
寿命 Life	电气 Electrical	100,000次以上 above
	机械 Mechanical	1,000,000次以上 above
防护等级 Protection degree		IP65
使用温度 Operating temperature		-10~+70°C
使用湿度 Operating humidity		<85%

## Product Structure

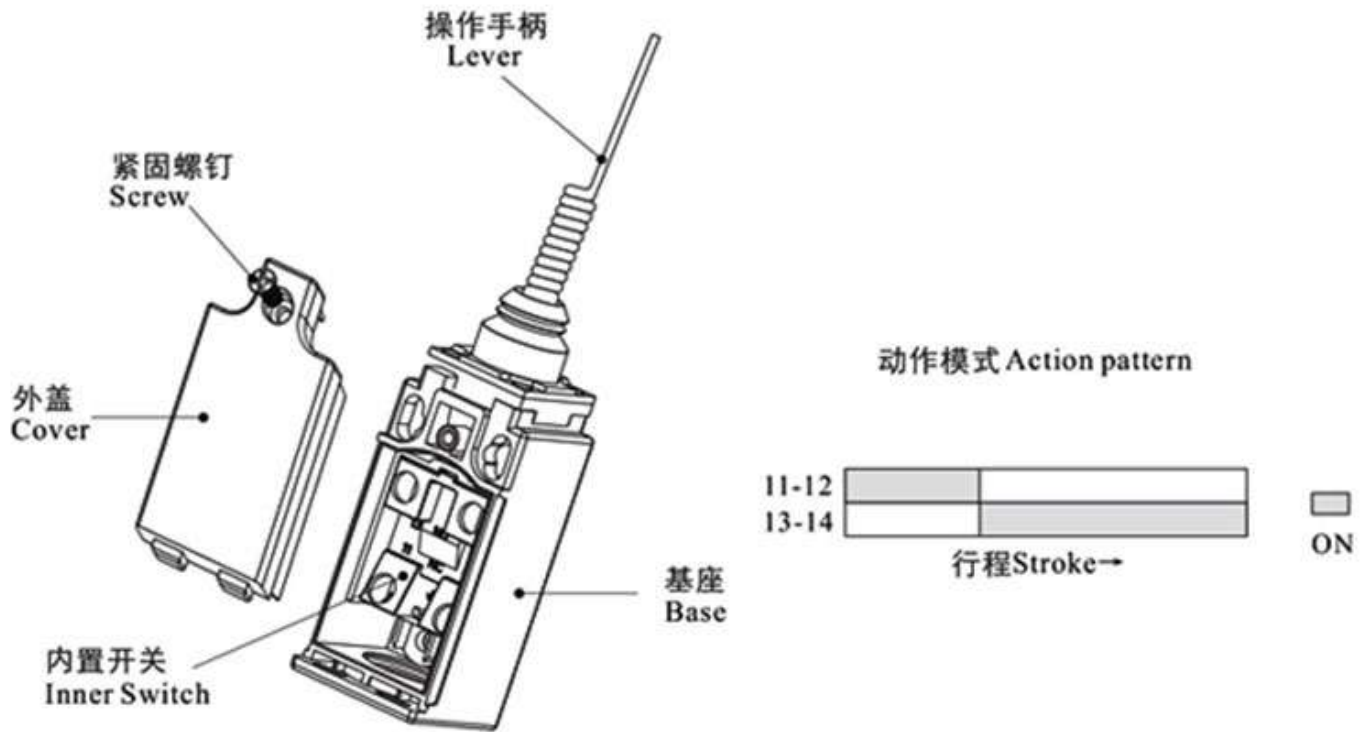

## Dimensions/Operating Characteristics

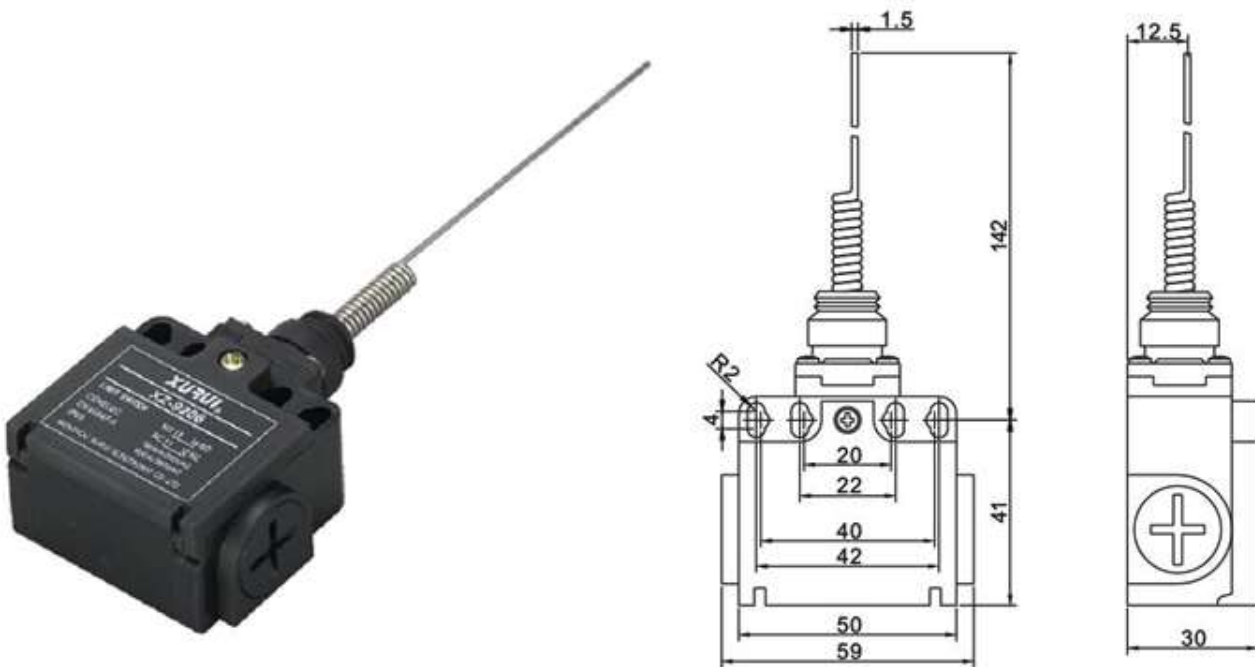

OF max.动作力	100g(0.98N)	OT min.超行程	20mm
RF min.回复力	30g(0.29N)	MD max.差行程	10mm
PT max.预行程	28mm	TT 总行程	48mm