

- Economic plastic housing, light weight;
- Preventing oil and water ;
- Double way switch, double spring inner switch;
- Variety of levers;
- Widely used in Mechanical equipment, automatic machine, and instrument, electro motion tool etc.

Model & Meanings

X Z - 9 101



Contact Form & Mounting Holes Dimensions

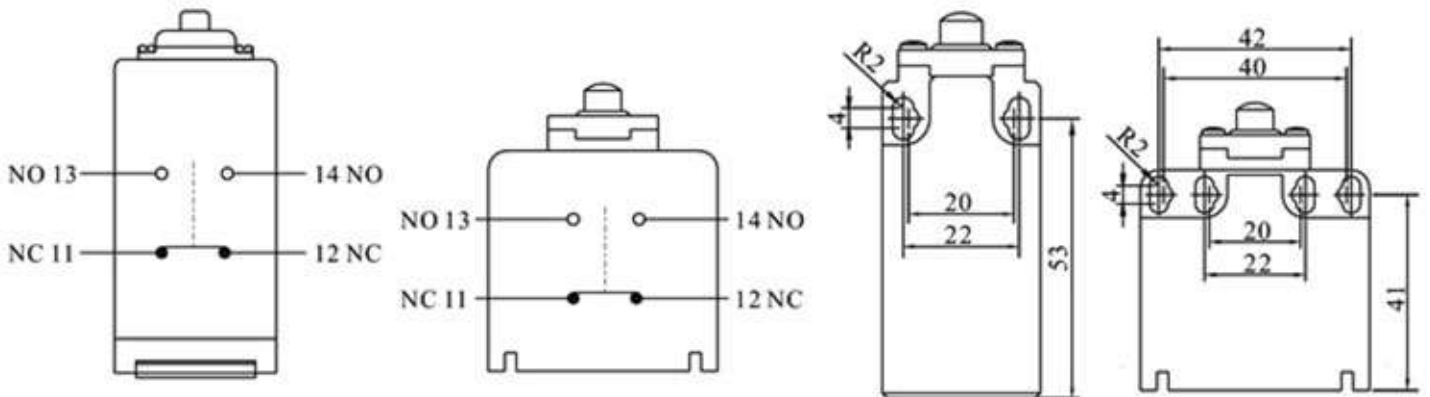

Specification

Item	Data	
Rating load	10(4)A/250VAC,6(2)A 380VAC	
Operation speed	5mm-0.5m/s	
Operation frequency	Mechanical	120times/min
	Electrical	30times/min
Insulation resistance	100mΩ(Above) DC500V	
Contact resistance	25mΩ (initial value)	
Withstand voltage	Non-connection wire	1000VAC
	Every terminal	1500VAC
Vibration	Misoperation	10-55Hz Amplitude 1.5mm
Impact	Durable	1000m/s ²
	Misoperation	300m/s ²
Life	Electrical	100,000 above
	Mechanical	1,000,000 above
Protection degree	IP65	
Operating temperature	-10~+70°C	
Operating humidity	<85%	

Product Structure

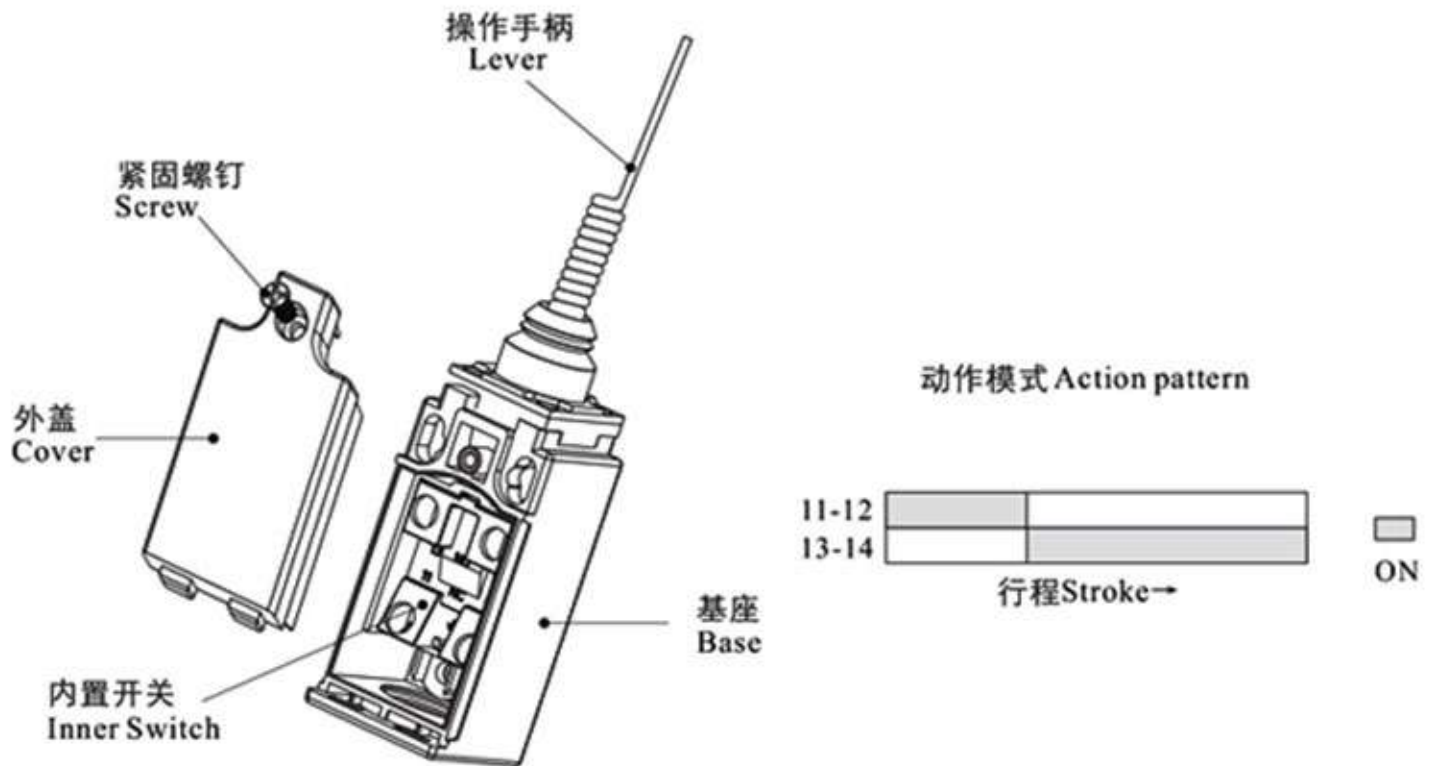

Dimensions/Operating Characteristics

- 可调大滚轮摆杆型
XZ-9110

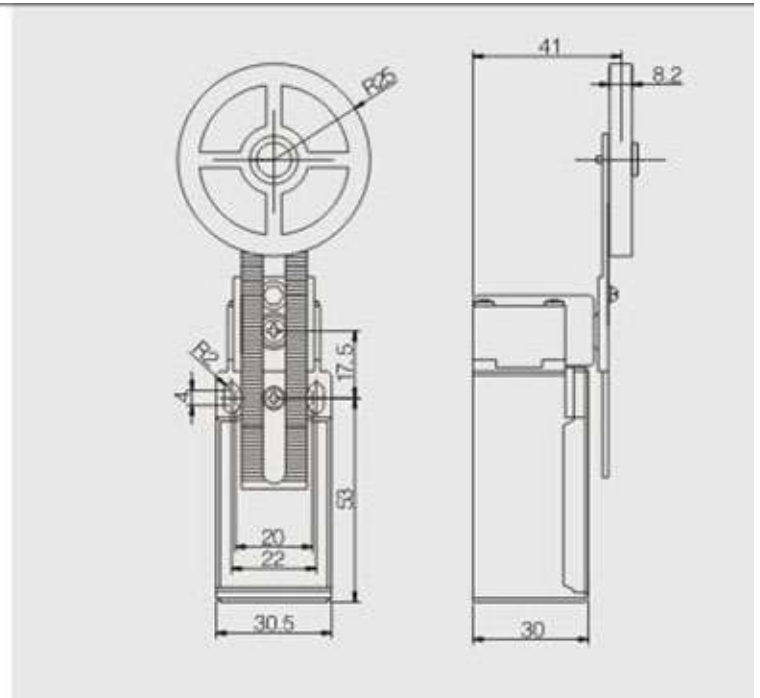

OF max.	500g(4.9N)	OT min.	70°
RF min.	80g(0.78N)	MD max.	15°
PT max.	30°	TT	90°