

Strong structure, made of zinc metal alloy and plastics, easy to contact line;

- Small size, water and oil resistant;
- Double way switch, double spring inner switch;
- Variety of levers;
- Widely used in Mechanical equipment, automatic machine, and instrument, electro motion tool etc.

Model & Meanings

X Z - 8 / 104

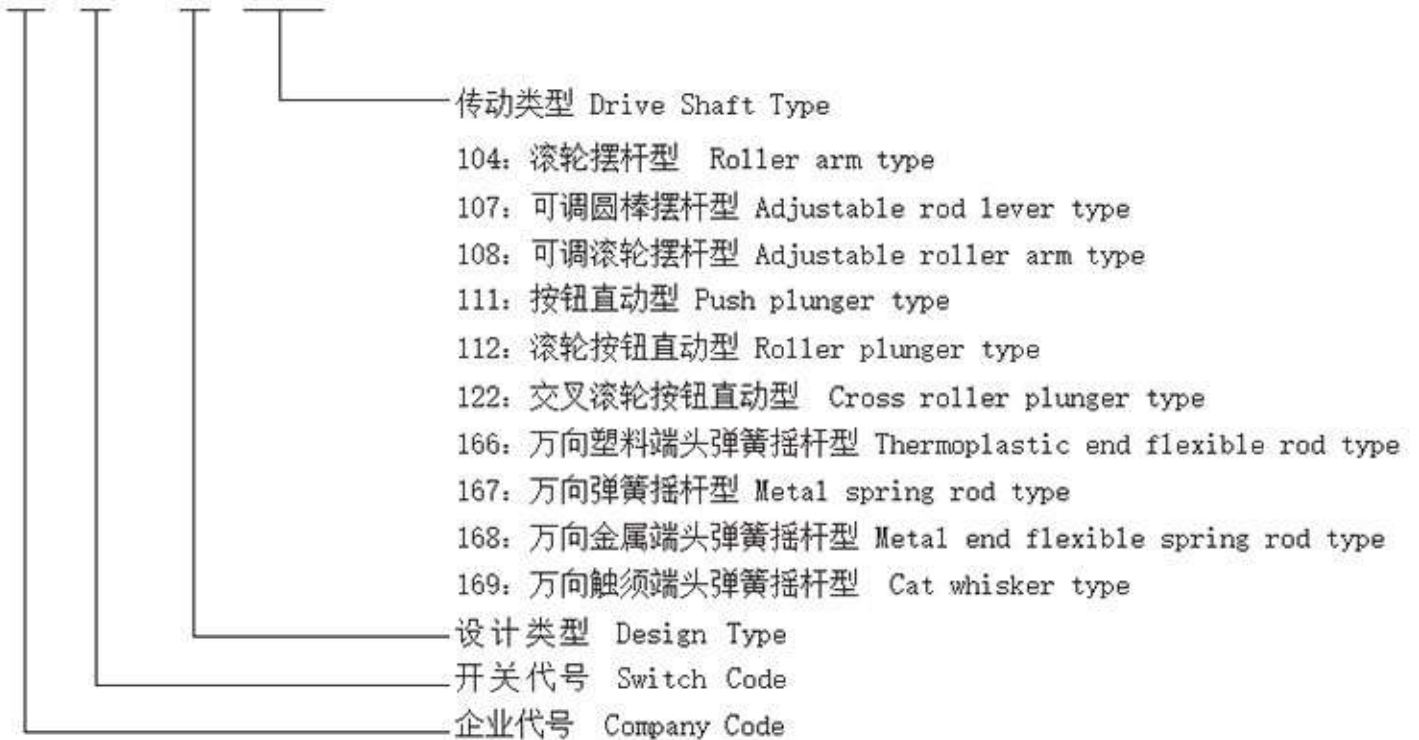

Mounting Holes & Contact Form

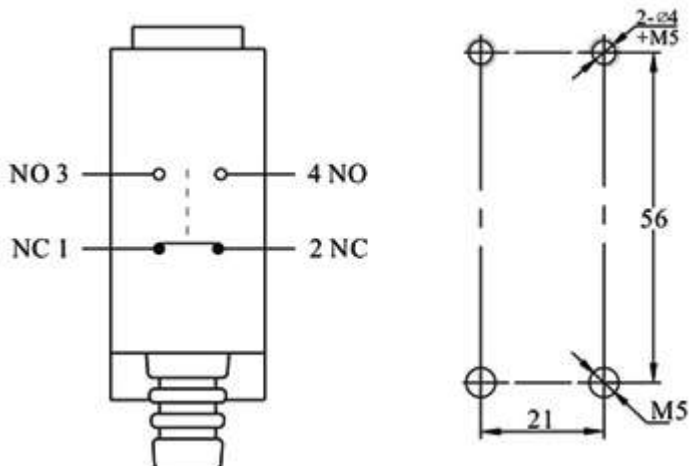

Product Structure

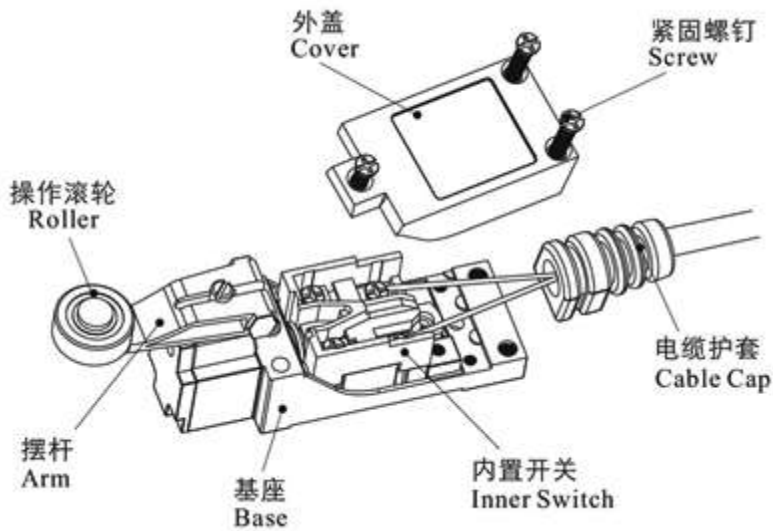

Specification

项目 Item	参数值 Data	
额定负荷 Rating load	5A/250VAC	
操作速度 Operation speed	5mm-50cm/s	
操作频率 Operation frequency	机械 Mechanical	120次/分 120times/min
	电气 Electrical	30次/分 30times/min
绝缘电阻 Insulation resistance	100mΩ以上(Above) DC500V	
接触电阻 Contact resistance	25mΩ初值 initial value)	
介质耐压 Withstand voltage	非连线 Non-connection wire	1000VAC
	各端子间 Every terminal	1500VAC
振动 Vibration	误动作 Misoperation	10-55Hz Amplitude (复振幅) 1.5mm
冲击 Impact	耐久 Durable	1000m/s ²
	误动作 Misoperation	300m/s ²

寿命 Life	电气 Electrical	100,000次以上 above
	机械 Mechanical	1,000,000次以上 above
防护等级 Protection degree	IP65	
使用温度 Operating temperature	-20~+60°C	
使用湿度 Operating humidity	<85%	

Dimensions/Operating Characteristics

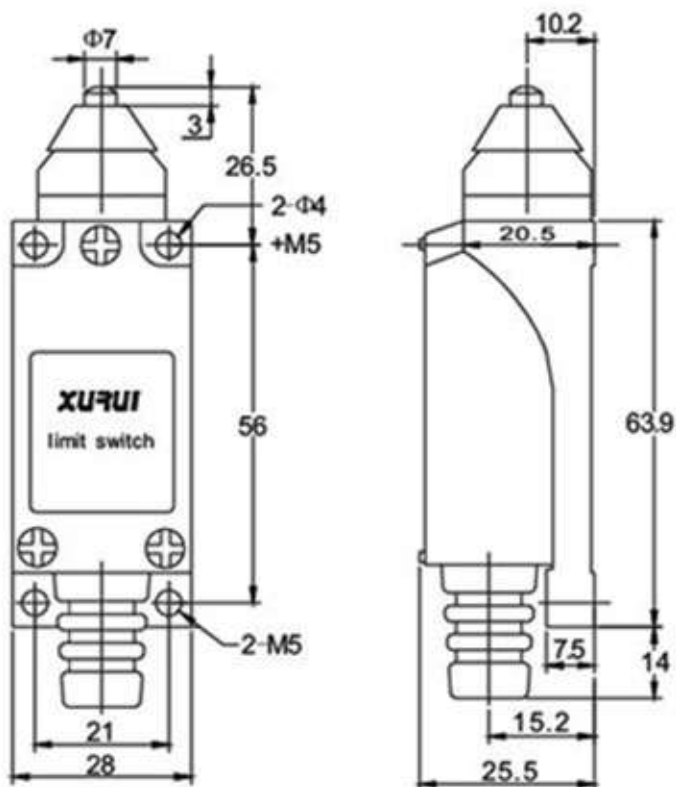

OF max.动作力	1100g(10.78N)
RF min.回复力	250g(2.45N)
PT max.预行程	2mm
OT min.超行程	0.6mm
MD max.差行程	1mm
TT 总行程	26±0.8mm