

# Product Information

# Periphery module

# PM AI404

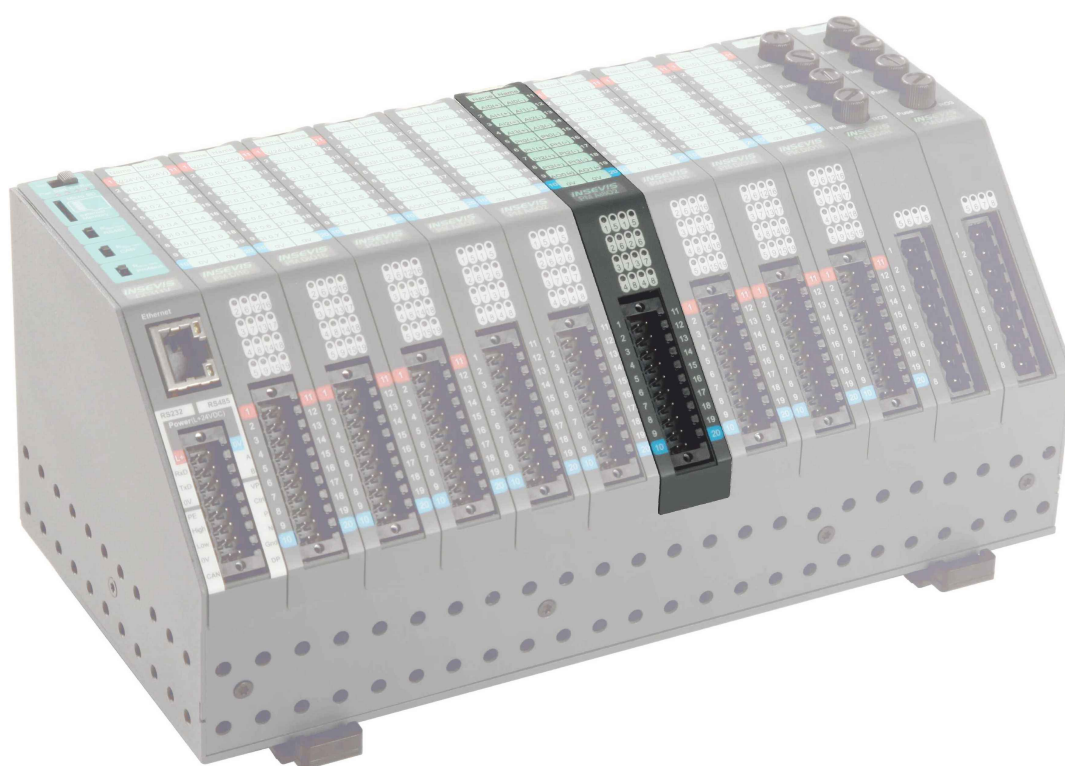

(valid from 04/2012, for all PLCs PC/CCxxxxV/P-03 with OS 2.0.35 and with ConfigStage 1.0.14.5)

## Changes to older versions of this document

**Changed in Rev. 5:** Increase of the resolution of analog inputs by expanding the integration time  
**Changed in Rev. 6:** Description of 3-/4-wire connections corrected (0V connected with Ref n)  
**Changed in Rev. 6:** Connectors, new design line

## Description

compact periphery module for

**- 4 analog inputs to be configured by software**

0...20mA, 4...20mA, 0...10 V, ±10V, ±5V, ±2,5V

**4 analog outputs to be configured by software**  
± 20mA, 4...20mA, ±10V

- Resolution 12 Bit
- green diagnostic LED for each input
  - LED 1 for AI0
  - LED 2 for AI1
  - LED 3 for AI2
  - LED 4 for AI3
  - LED 5 for AO0
  - LED 6 for AO1
  - LED 7 for AO2
  - LED 8 for AO3

- red diagnostic LED for each input for error (sensor-/ broken wire detection)

- LED 1 for AI0
- LED 2 for AI1
- LED 3 for AI2
- LED 4 for AI3
- (or output error flag)
- LED 5 for AO0
- LED 6 for AO1
- LED 7 for AO2
- LED 8 for AO3

- Increase of the resolution of analog inputs by expanding the integration time up to 16Bit

- insertion stripe with description field for every signal

- cage-clamp connector with 2 lift arms or bolt flanges on side

### INSEVIS-benefit:

This module has an internal supply for the 2-wire encoders (4-20mA). So it is not necessary to care for external supply!

**If you use these pins 1-4, do not apply external encoder supply!**

**Always connect Ref0..3 with analog ground (0V)**

## for 2-wire encoders

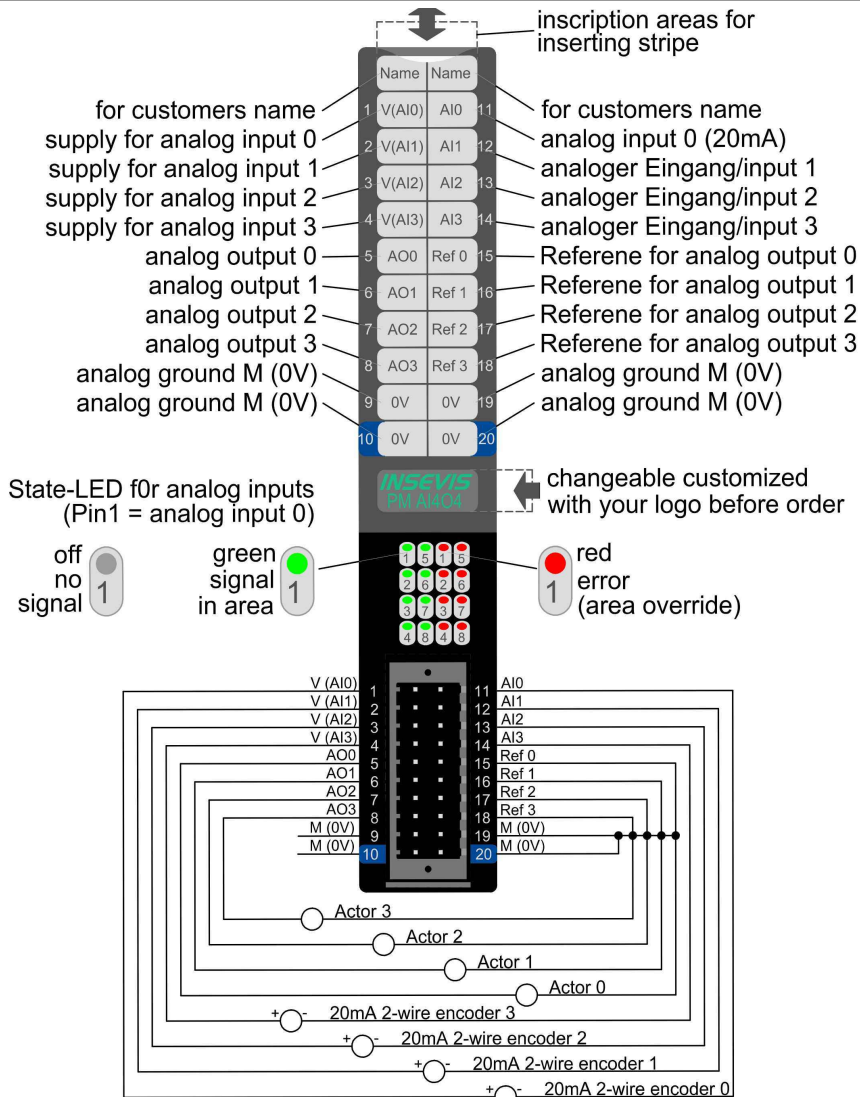

Figure above: Description and wiring of all connections of PM AI4O4 with 2-wire encoders

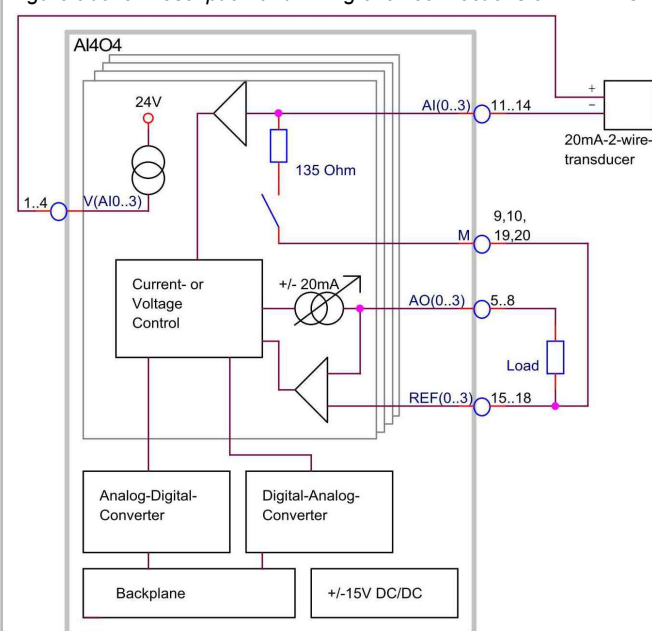

Figure above: Block diagram of PM AI4O4 with 2-wire encoders

Input		
Start address:	128	
End address:	135	
Channel	Address	Mode
Channel 1:	128	+/- 10V
Channel 2:	130	+/- 5V
Channel 3:	132	+/- 2.5V
Channel 4:	134	0..10V
Output		
Start address:	128	
End address:	135	
Channel	Address	Mode
Channel 1:	128	+/- 10V
Channel 2:	130	4..20mA
Channel 3:	132	+/- 20mA
Channel 4:	134	+/- 10V

Figure above: configuration block of start-/end addresses of AI4O4-i/o's (in words) in the ConfigStage

## Description

## for 3-/ 4-wire encoders or $\pm 10V$ voltage source

compact periphery module for

**- 4 analog inputs to be configured by software**

0...20mA, 4...20mA, 0...10 V,  $\pm 10V$ ,  $\pm 5V$ ,  $\pm 2,5V$

**4 analog outputs to be configured by software**

$\pm 20mA$ , 4...20mA,  $\pm 10V$

- Resolution 12 Bit
- green diagnostic LED for each input
  - LED 1 for AI0
  - LED 2 for AI1
  - LED 3 for AI2
  - LED 4 for AI3
  - LED 5 for AO0
  - LED 6 for AO1
  - LED 7 for AO2
  - LED 8 for AO3

- red diagnostic LED for each input for error (sensor-/ broken wire detection)
  - LED 1 for AI0
  - LED 2 for AI1
  - LED 3 for AI2
  - LED 4 for AI3

(or output error flag)

- LED 5 for AO0
- LED 6 for AO1
- LED 7 for AO2
- LED 8 for AO3

- Increase of the resolution of analog inputs by expanding the integration time up to 16 Bit

- insertion stripe with description field for every signal

- cage-clamp connector with 2 lift arms or bolt flanges on side

**Attention!**

This module has an internal supply for the 2-wire encoders (4-20mA).

**Do not connect pins 1-4 when using 3/4-wire encoders!**

**Always connect Ref0..3 with analog ground (0V)**

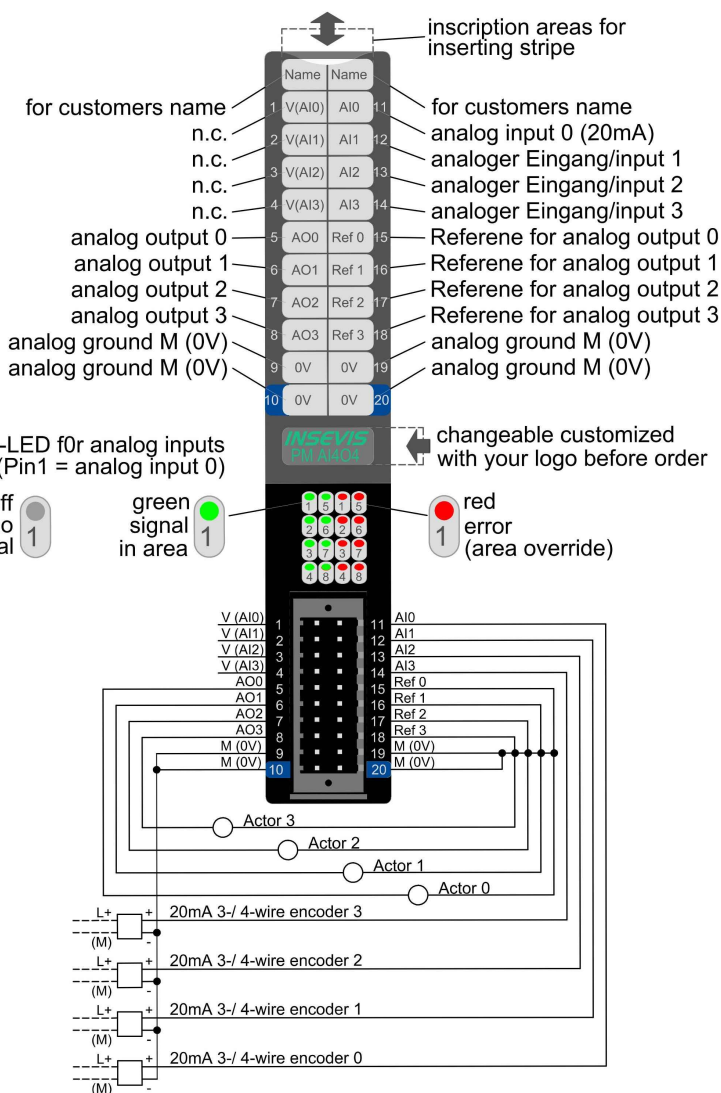

Figure above: Description and wiring of all connections of PM AI4O4 with 3-/ 4-wire encoders or  $\pm 10V$

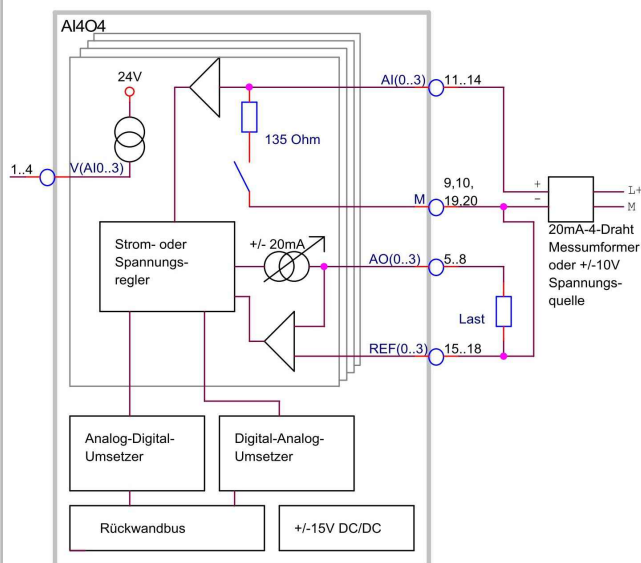

Figure above: Block diagram of PM AI4O4 with 4-wire encoders or  $\pm 10V$  voltage source

Input		
Start address:	128	
End address:	135	
Channel	Address	Mode
Channel 1:	128	+/- 10V
Channel 2:	130	+/- 10V
Channel 3:	132	+/- 5V
Channel 4:	134	+/- 2.5V
		0...10V
		4...20mA
		0...20mA
Output		
Start address:	128	
End address:	135	
Channel	Address	Mode
Channel 1:	128	+/- 10V
Channel 2:	130	4...20mA
Channel 3:	132	+/- 20mA
Channel 4:	134	+/- 10V

Figure above: configuration block of 3-/ start-/ end addresses of AI4O4-i/o's (in words) in the ConfigStage

Technical data			
Operating temperature range Storage temperature range Dimensions W x H x D (mm) Weight	-20°C ... +60°C (without condens.) -30°C ... +80°C 20 x 108 x 70 mm ca. 150 g	Load voltage L+ Current consumption Power dissipation	24V DC (10V ... 30V DC, connected by device supply) 250 mA (max.) 4 W (max.)
Connection technology	connector with cage clamp technology for cross section up to max. 1,5mm <sup>2</sup>	Wire length unshielded (max.) shielded (max.)	30 m 100 m
<b>Analog inputs</b> Input area (nominal values)	4 (to be configured by software) 0...20mA, 4...20mA ±10V, ±5V, ±2,5V, 0..10V	Valid voltage between inputs and A-GND (max.)	-15 V ... +24 V DC
Diagnostic LEDs	4 green: signal in valid area 4 red: override (mA) or saturation no displaying broken wires and open inputs	Error message during override metering area	adjustable diagnosis- and limit value alert on request
Value number format	0000 ... 6C00 (hexadecimal) for range mA and 0 ... 10V all other 9400 ... 6C00 (hexadecimal)	Broken wire detection	by overrun / shortfall of metering area
Override area	20 mA ... 22 mA (only at mAs)	Access of sensor	unsymmetric against A-GND (single ended)
Input resistance	150Ω (typ.) metering area current 100kΩ (typ.) metering area voltage	Metering principle / conversion principle Resolution depending on integration time *	successive approximation  12 Bit ... 16 Bit
Sampling cycle time = Integration time *	adjustable 1ms ... 35767 ms default: 100 ms (=Net frequency filter 50Hz and 60Hz)	Specificity (based on input area)	< 1%
<b>Analog outputs</b> Output area (nominal values)	4 (to be configured by software) ±20mA, 4...20mA, ±10V	Value number format	0000 ... 6C00 (hexadecimal) for range mA and 0 ... 10V all other 9400 ... 6C00 (hexadecimal)
Resolution	12 Bit	Short cut protection	yes
Diagnostic LEDs	4 green: signal in valid area 4 rot: override (mA) or short circuit	Override area	20 ... 23 mA, -20 ... -23 mA 10 ... 11,3V, -10 ... -11,3V
Setting time: response time τ (typ)	1,5 ms	Short cut current (typ.)	32 mA
Load resistance against A-GND	mA: 500 Ω (max.) V: 1 kΩ (min.)	Specificity (based on output area)	< 1%

**\* Increase of the resolution of analog inputs by expanding the integration time (configurable in ConfigStage at the PM-AI4O4 directly)**

for 0..10V:	0...16ms → 13Bit	17...64ms → 14Bit	65...256ms → 15Bit
for 0(4)..20mA:	0...16ms → 12Bit	17...64ms → 13Bit	65...256ms → 14Bit > 265ms → 15Bit
for ±2,5V, ±5V, ±10V:	0...16ms → 12Bit	17...64ms → 13Bit	65...256ms → 14Bit > 265ms → 15Bit
	(+sign)	(+sign)	(+sign)

Configuration of the process image Hardware version 2.0: The module allocates 8 input words and 4 output words in the process image.			
Offset	I/O	Function	Description
0,2,4,6	I	Input AI0..AI3	Measuring range according to configuration
0,2,4,6	O	Output AO0..AO3	Measuring range according to configuration
8,10,12,14	I	State of the (backreadable) outputs AO0..AO3	.0 FCM Common-Mode Over-Range .1 FLD Load Error .2 FOT Over Temperature .15 ... .3 0 ... 6C00 (hex) at mA: output voltage 0 ... 10V at ±10V: output current 0 ... 20mA

## Ordering data module

Identification	Order-no.	Packaging unit
Periphery module <b>AI4O4</b>	PM-AI4O4-02	PU: 1 piece

## Ordering data accessoires

Identification	Order-no.	Packaging unit
Connector 2x10pin with pin markings and lift arms on side	E-CON20A-00	PU: 1 piece
Connector 2x10pin with pin markings and bolt flanges on side	E-CONS20A-00	PU: 1 piece
Spare part: Inserting stripe for description fields, 2x11 fields *	E-LABES22-00	PU: 20 pieces
Inserting stripe V for logo and identification for rear side *	E-LABV-00	PU: 100 pieces

\* (1x already part of first deliveries scope)

### Qualified personnel

All devices described in this manual may only be used, built up and operated together with this documentation. Installation, initiation and operation of these devices might only be done by instructed personnel with certified skills, who can prove their ability to install and initiate electrical and mechanical devices, systems and current circuits in a generally accepted and admitted standard.

### Manuals, sample programs

Additional documentation by manuals is available as well sample applications at the download area of [www.insevis.com](http://www.insevis.com) in English language for free download.

### Copyright

This and all other documentation and software, supplied or hosted on INSEVIS web sites to download are copyrighted. Any duplicating of these data in any way without express approval by INSEVIS GmbH is not permitted. All property and copy rights of these documentation and software and every copy of it are reserved to INSEVIS GmbH.

### Trade Marks

INSEVIS refers that all trade marks of particular companies used in own documentation are reserved trade marks are property of the particular owners and are subjected to common protection of trade marks.

### Disclaimer

All technical details in this documentation were created by INSEVIS with highest diligence. Anyhow mistakes could not be excluded, so no responsibility is taken by INSEVIS for the complete correctness of this information. This documentation will reviewed regularly and necessary corrections will be done in next version.

With publication of this information all other versions are no longer valid.