

- » Sleek design with NEW 18 mm width in accordance with DIN norm
- » Conforms to IEC 61812-1
- » Wide power supply range (12-240 V AC/DC)
- » SPDT relay output (10A)
- » Wide and easily adjustable time range
- » LED notifications
- » High sensitivity and switching capacity
- » High mechanical endurance

Type	Order No	Mode	Relay Count	Time Range
Z1A-ND30s	261025	ND	1 C/O	1 sec .. 30 sec
Z1A-ND100s	261023	ND	1 C/O	1 sec .. 100 sec
Z1T-ND100s	261010	ND	1 C/O	1 sec .. 100 sec
Z1T-PFD120m-24	261011	PFD	1 C/O	1 sec .. 120 min
Z1T-PFD120s-24	261030	PFD	1 C/O	1 sn .. 120 sec
Z1T-NDX	261012	ND	1 C/O	0 sec .. 5109 sec
Z1T-FDF	261013	FDF	1 C/O	0.1 sec .. 10 days
Z1T-NDF	261014	NDF	1 C/O	0.1 sec .. 10 days
Z1T-ND100s.2	261026	ND	2 C/O	1 sec .. 100 sec

Operating Voltage		12..240V AC/DC ±10% 24..240V AC/DC ±10% (for Z1T-PFD120m-24, Z1T-PFD120m/s-24) 24V AC/DC (A2-A3 ve 180 .. 265V AC (A1-A3) (Z1A-xxx for
Operating Frequency		45..65Hz
Power Consumption	DC	< 1.5 W < 8 W (for Z1T-PFD120m-24)
	AC	< 5 VA < 8 VA (for Z1T-PFD120m-24)
Relay Outputs	Maximum Switching (Voltage/Current/Power)	250VAC / 10A / 1250 VA
Cable Cross Section		2.5mm ² / 14 AWG
Screw Tightening Torque		0.5 Nm
Cable Stripping Size (Min / Max)		8mm / 9mm
Operating Temperature Range		-20 / +60 °C
Protection Degree (IEC 60529)		IP 20

NOTE: The charging time of the Z1T-PFD120m-24 product varies between 3 seconds and 1 minute, and the charging time of the Z1T-PFD120s-24 product varies between 3 and 10 seconds.

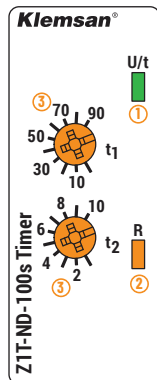
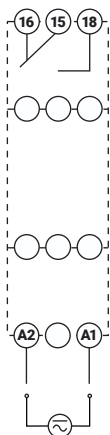
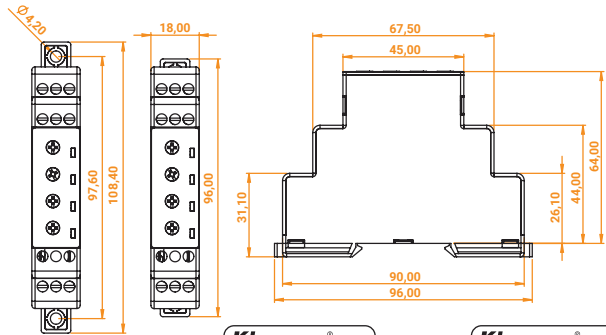

- Power Status LED
- Relay Status LED
- "toff" Delay Adjustment Pots t1+t2

NOTE: On delay time duration is set via one knob for the Z1A-NDxxx series

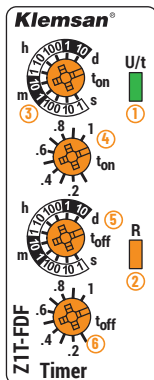

- Power Status LED
- Relay Status LED
- "ton" Delay Time Range Adjustment Pot
- "ton" Delay Multiplier Adjustment Pot
- "toff" Delay Time Range Adjustment Pot
- "toff" Delay Multiplier Adjustment Pot

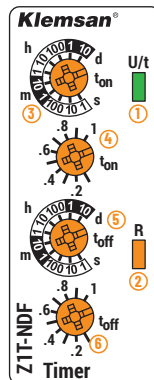

- Power Status LED
- Relay Status LED
- "ton" Delay Time Range Adjustment Pot
- "ton" Delay Multiplier Adjustment Pot
- "toff" Delay Time Range Adjustment Pot
- "toff" Delay Multiplier Adjustment Pot

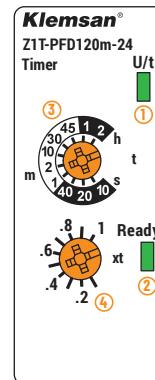

- Power Status LED
- Relay Status LED
- "ton" Delay Time Range Adjustment Pot
- "ton" Delay Multiplier Adjustment Pot

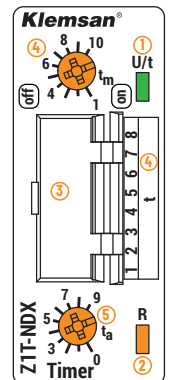

- Power Status LED
- Relay Status LED
- "toff" Delay Time Range Adjustment Switches
- "toff" Delay Multiplier Adjustment Pot (xtm)
- "toff" Delay Additional Time Adjustment Pot (+ta)

OFF (0)	1	2	3	4	5	6	7	8
ON (1)	11	12	13	14	15	16	17	18
	2	4	8	16	32	64	128	256

toff: (t1+..+t8)xtm+ta

OPERATION MODE	FUNCTION ILLUSTRATION	FUNCTION STATEMENT
On Delay (mod: ND)		The output relay is initially de-energized and energized after an adjustable time delay, t_{off} .
OFF Flash (mod: FDF)		The output relay is initially de-energized and energized after an adjustable time delay, t_{off} , and stays energized for an adjustable period, t_{on} , and then de-energized. This loop is repeated until the device is powered off.
ON Flash (mod: NDF)		The output relay is initially energized and de-energized after an adjustable time delay, t_{on} , and stays de-energized for an adjustable period, t_{off} , and then energized. This loop is repeated until the device is powered off.
Power-Off Delay (mod: PFD)		The output relay is initially energized and the device starts to charge. When the device is power off, the output relay remains energized until the adjusted time. The loop starts again when the device is power on.