

- » DIN normuna uygun YENİ 18 mm genişliğinde şık tasarım,
- » IEC 61812-1 standardına uygun,
- » Geniş çalışma gerilimi aralığı (12-240 V AC/DC),
- » SPDT röle çıkışı (10A),
- » Geniş ve kolay ayarlanabilir zaman aralığı,
- » LED bildirimler,
- » Yüksek hassasiyet ve anahtarlama dayanımı,
- » Yüksek mekanik dayanıklılık.

Ürün Adı	Sipariş No	Fonksiyon	Röle Sayısı	Zaman Ayarı
Z1A-ND30s	261025	ND	1 C/O	1 sn .. 30 sn
Z1A-ND100s	261023	ND	1 C/O	1 sn .. 100 sn
Z1T-ND100s	261010	ND	1 C/O	1 sn .. 100 sn
Z1T-PFD120m-24	261011	PFD	1 C/O	1 sn .. 120 dk
Z1T-PFD120s-24	261030	PFD	1 C/O	1 sn .. 120 sn
Z1T-NDX	261012	ND	1 C/O	0 sn .. 5109 sn
Z1T-FDF	261013	FDF	1 C/O	0.1 sn .. 10 gün
Z1T-NDF	261014	NDF	1 C/O	0.1 sn .. 10 gün
Z1T-ND100s.2	261026	ND	2 C/O	1 sn .. 100 sn

Besleme Gerilimi	12..240V AC/DC ±10% 24..240V AC/DC ±10% (Z1T-PFD120m-24, Z1T-PFD120m/s-24 için) 24V AC/DC (A2-A3 ve 180 .. 265V AC (A1-A3) (Z1A-xxx için)	
Besleme Frekansı	45..65Hz	
Güç Tüketimi	DC	< 1.5 W < 8 W (Z1T-PFD120m-24, Z1T-PFD120m/s-24 için)
	AC	< 5 VA < 8 VA (Z1T-PFD120m-24, Z1T-PFD120m/s-24 için)
Röle Çıkışları	Maksimum Anahtarlama Gerilim / Akım / Güç) 250VAC / 10A / 1250 VA	
Kablo Kesiti	2.5mm <sup>2</sup> / 14 AWG	
Vida Sıkma Torku	0.5 Nm	
Kablo Soyma Boyutu (Min / Max)	8mm / 9mm	
Çalışma Sıcaklığı Aralığı	-20 / +60 °C	
Koruma Derecesi (IEC 60529)	IP 20	

NOT : Z1T-PFD120m-24 ürünün şarj süresi 3sn ile 1 dk arasında,  
Z1T-PFD120s-24 ürünün şarj süresi ise 3 ile 10 sn arasında değişmektedir.

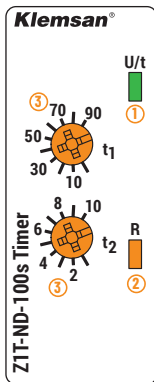
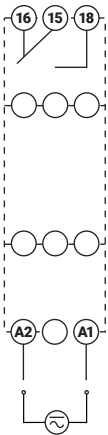
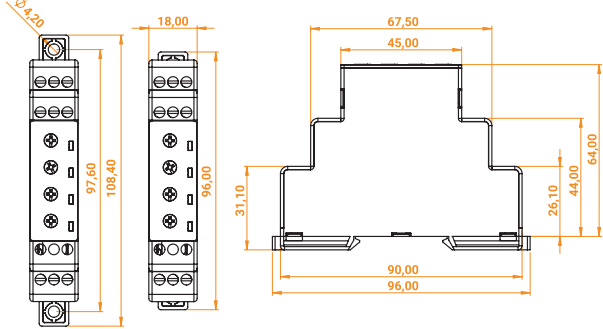

- Güç Durumu LED'i
- Röle Durumu LED'i
- "toff" Gecikme Ayar Potları t1+t2

NOT: Z1A-NDxxx ürünleri için çekme gecikmesi ayarı tek pot üzerinden yapılmaktadır.

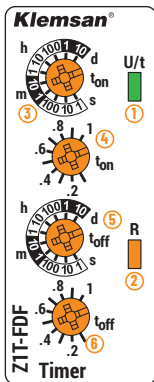

- Güç Durumu LED'i
- Röle Durumu LED'i
- "ton" Gecikme Zaman Dilimi Ayar Potu
- "ton" Gecikme Çarpan Değeri Ayar Potu
- "toff" Gecikme Zaman Dilimi Ayar Potu
- "toff" Gecikme Çarpan Değeri Ayar Potu

NOT: Z1T-NDxxx ürünleri için çekme gecikmesi ayarı tek pot üzerinden yapılmaktadır.

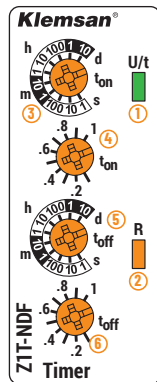

- Güç Durumu LED'i
- Röle Durumu LED'i
- "ton" Gecikme Zaman Dilimi Ayar Potu
- "ton" Gecikme Çarpan Değeri Ayar Potu
- "toff" Gecikme Zaman Dilimi Ayar Potu
- "toff" Gecikme Çarpan Değeri Ayar Potu

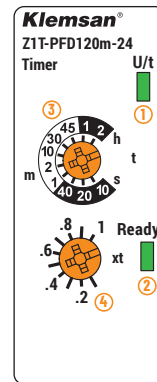

- Güç Durumu LED'i
- Cihaz Hazır LED'i
- "ton" Gecikme Zaman Dilimi Ayar Potu
- "toff" Gecikme Çarpan Değeri Ayar Potu

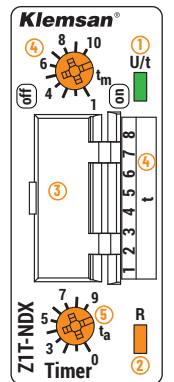

- Güç Durumu LED'i
- Röle Durumu LED'i
- "toff" Gecikme Zaman Dilimi Ayar Switch'leri
- "ton" Gecikme Çarpan Değeri Ayar Potu (xtm)
- "toff" Gecikme İlave Süre Ayar Potu (+ta)

OFF (0)	1	2	3	4	5	6	7	8
ON (1)	11	12	13	14	15	16	17	18
	2	4	8	16	32	64	128	256

toff: (t1+...+t8)xtm+ta

ÇALIŞMA MODU	FONKSİYON TANIMI	FONKSİYON AÇIKLAMASI
Çekme Gecikmesi (mod: ND)	R: U/t:	Çıkış rölesi cihaz çalıştırıldığında enerjisiz konumdadır ve ayarlanan toff süresi bitiminde çeker.
Kapalı Flaşör (mod: FDF)	R: U/t:	Çıkış rölesi cihaz çalıştırıldığında enerjisiz konumdadır ve ayarlanan Toff süresi bitiminde çeker. Ayarlanan Ton süresi kadar iletimde kaldıktan sonra bırakır ve bu döngü böyle devam eder.
Açık Flaşör (mod: NDF)	R: U/t:	Çıkış rölesi cihaz çalıştırıldığında çekili konumdadır ve ayarlanan ton süresi bitiminde bırakır. Ayarlanan toff süresi kadar enerjisiz kaldıktan sonra çeker ve bu döngü böyle devam eder.
Güç Kapalı Bırakma Gecikmesi (mod: PFD)	U/t: Ready: R:	Cihaz, enerjilendiği anda çıkış rölesi aktif olur ve cihaz şarj olmaya başlar. Cihazın enerjisi kesildiği andan itibaren, ayarlanan t süresi sonunda çıkış rölesi deaktif olur.

- » Sleek design with NEW 18 mm width in accordance with DIN norm
- » Conforms to IEC 61812-1
- » Wide power supply range (12-240 V AC/DC)
- » SPDT relay output (10A)
- » Wide and easily adjustable time range
- » LED notifications
- » High sensitivity and switching capacity
- » High mechanical endurance

Type	Order No	Mode	Relay Count	Time Range
Z1A-ND30s	261025	ND	1 C/O	1 sec .. 30 sec
Z1A-ND100s	261023	ND	1 C/O	1 sec .. 100 sec
Z1T-ND100s	261010	ND	1 C/O	1 sec .. 100 sec
Z1T-PFD120m-24	261011	PFD	1 C/O	1 sec .. 120 min
Z1T-PFD120s-24	261030	PFD	1 C/O	1 sn .. 120 sec
Z1T-NDX	261012	ND	1 C/O	0 sec .. 5109 sec
Z1T-FDF	261013	FDF	1 C/O	0.1 sec .. 10 days
Z1T-NDF	261014	NDF	1 C/O	0.1 sec .. 10 days
Z1T-ND100s.2	261026	ND	2 C/O	1 sec .. 100 sec

<b>Operating Voltage</b>		12..240V AC/DC ±10% 24..240V AC/DC ±10% (for Z1T-PFD120m-24, Z1T-PFD120m/s-24) 24V AC/DC (A2-A3 ve 180 .. 265V AC (A1-A3) (Z1A-xxx for
<b>Operating Frequency</b>		45..65Hz
<b>Power Consumption</b>	DC	< 1.5 W < 8 W (for Z1T-PFD120m-24)
	AC	< 5 VA < 8 VA (for Z1T-PFD120m-24)
<b>Relay Outputs</b>		Maximum Switching (Voltage/Current/Power) 250VAC / 10A / 1250 VA
<b>Cable Cross Section</b>		2.5mm <sup>2</sup> / 14 AWG
<b>Screw Tightening Torque</b>		0.5 Nm
<b>Cable Stripping Size (Min / Max)</b>		8mm / 9mm
<b>Operating Temperature Range</b>		-20 / +60 °C
<b>Protection Degree (IEC 60529)</b>		IP 20

NOTE: The charging time of the Z1T-PFD120m-24 product varies between 3 seconds and 1 minute, and the charging time of the Z1T-PFD120s-24 product varies between 3 and 10 seconds.

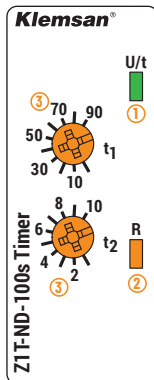
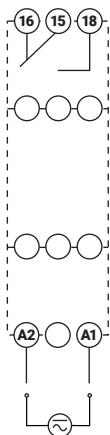
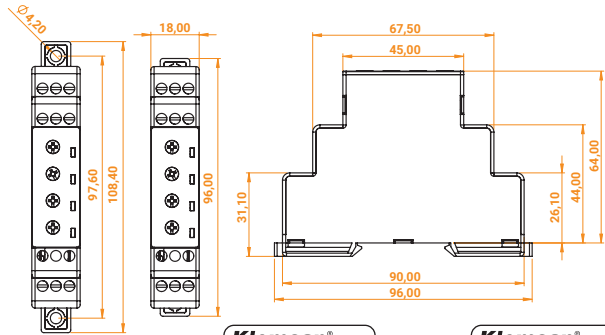

- Power Status LED
- Relay Status LED
- "toff" Delay Adjustment Pots t1+t2

NOTE: On delay time duration is set via one knob for the Z1A-NDxxx series

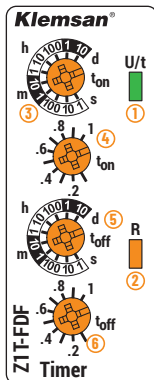

- Power Status LED
- Relay Status LED
- "ton" Delay Time Range Adjustment Pot
- "ton" Delay Multiplier Adjustment Pot
- "toff" Delay Time Range Adjustment Pot
- "toff" Delay Multiplier Adjustment Pot

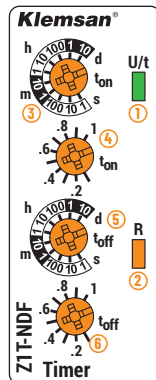

- Power Status LED
- Relay Status LED
- "ton" Delay Time Range Adjustment Pot
- "ton" Delay Multiplier Adjustment Pot
- "toff" Delay Time Range Adjustment Pot
- "toff" Delay Multiplier Adjustment Pot

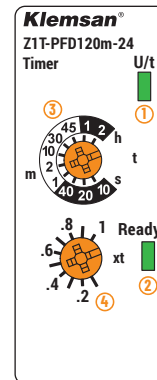

- Power Status LED
- Relay Status LED
- "ton" Delay Time Range Adjustment Pot
- "ton" Delay Multiplier Adjustment Pot

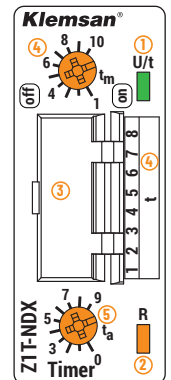

- Power Status LED
- Relay Status LED
- "toff" Delay Time Range Adjustment Switches
- "toff" Delay Multiplier Adjustment Pot (xtm)
- "toff" Delay Additional Time Adjustment Pot (+ta)

OFF (0)	1	2	3	4	5	6	7	8
ON (1)	11	12	13	14	15	16	17	18
	2	4	8	16	32	64	128	256

toff: (t1+..+t8)xtm+ta

OPERATION MODE	FUNCTION ILLUSTRATION	FUNCTION STATEMENT
<b>On Delay (mod: ND)</b>		The output relay is initially de-energized and energized after an adjustable time delay, $t_{off}$ .
<b>OFF Flash (mod: FDF)</b>		The output relay is initially de-energized and energized after an adjustable time delay, $t_{off}$ , and stays energized for an adjustable period, $t_{on}$ , and then de-energized. This loop is repeated until the device is powered off.
<b>ON Flash (mod: NDF)</b>		The output relay is initially energized and de-energized after an adjustable time delay, $t_{on}$ , and stays de-energized for an adjustable period, $t_{off}$ , and then energized. This loop is repeated until the device is powered off.
<b>Power-Off Delay (mod: PFD)</b>		The output relay is initially energized and the device starts to charge. When the device is power off, the output relay remains energized until the adjusted time. The loop starts again when the device is power on.