

DM²® Series D PRESS DOUBLE VALVES

Monitored Valves For Clutch/Brake Control



Thank You!

You have purchased a premium-quality ROSS® pneumatic valve. It is a high quality DM²® Series D double valve with dynamic monitoring and inherent lockout capability, for Category 4 applications. The valve is designed for base mounting for ease of installation and maintenance. With care in its installation and maintenance you can expect it to have a long and economical service life. Before you install this valve, read the information in this folder completely, and save it for future reference.

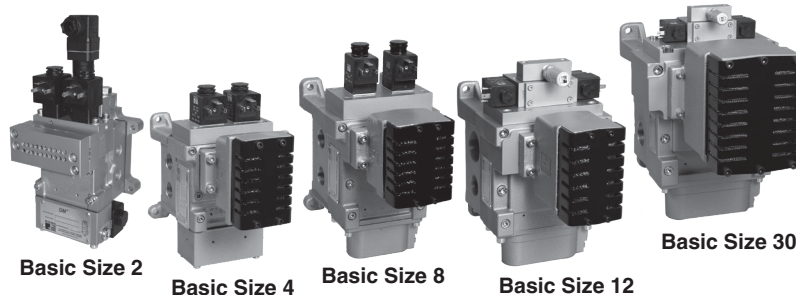

VALVE INSTALLATION

Please read and make sure you understand all installation instructions before proceeding with the installation.

Additional technical documentation is available for download at www.rosscontrols.com.

If you have any questions about installation or servicing your valve, please contact ROSS or your authorized ROSS distributor, see contact information listed at the back of this document, or visit www.rosscontrols.com to find your distributor.

Pneumatic equipment should be installed only by persons trained and experienced in such installation.

Air Lines: Before installing this valve in a new or existing system, the air lines must be blown clean of all contaminants. It is recommended that a 5-micron-rated air filter be installed in the inlet line close to the valve.

Valve Inlet (Port 1): Be sure that the supply line is of adequate size and does not have any restrictions (e.g., a crimp in the line, a sharp bend, or a clogged filter element). The air supply must not only provide sufficient pressure (see *Standard Specifications, page 3*), but must also provide an adequate flow of air on demand. Otherwise, the valve elements will be momentarily starved for air and the valve may fail to operate.

Valve Outlet (Port 2): For faster pressurizing and exhausting of the mechanism being operated by the valve, locate the valve as close as possible to the mechanism. The lines must be of adequate size and be free of restrictions (e.g., a crimp in the line, a sharp bend, or a clogged filter element).

Valve Exhaust (Port 3): Do not restrict the air flow from the exhaust port as this can adversely affect the operation of the valve. The valves are factory equipped with a properly sized silencer. ROSS silencers reduce impact noise by as much as 25 dB, and produce little back pressure.

Reset Port (RESET): If your valve is not equipped with a reset solenoid on the valve, then the RESET port should be supplied, externally, from a 3/2 normally closed valve. The lines must be of adequate size and be free of restrictions (e.g., a crimp in the line, a sharp bend, or a clogged filter element). Reset signals must be momentary.

Electrical Supply: DM²® Series D double valves get electrical power through plug-in connectors. The electrical supply must correspond to the voltage and Hertz ratings of the solenoids. Otherwise, the solenoids are subject to early failure. If power is supplied by a transformer, the power supply must be capable of handling the maximum power. See *Valve Specifications* on page 3 for information on maximum power.

Operating Pressures and Temperatures: Allowable ranges for pressure and temperatures are given in the *Standard Specifications* on page 3. Exceeding these values can adversely affect performance and shorten valve life.

Pipe Installation: To install pipe in base ports, engage the pipe by one turn, then apply pipe thread sealant (tape not recommended), and tighten pipe. This procedure will prevent sealant from entering and contaminating the valve. To install pipe with parallel threads (e.g., SAE, ISO 228-G, etc.) do not use sealant. After installing pipe into the base ports, use compressed air to blow any debris out of the piping, then install the valve onto the base.

Test: After installation or repair, and prior to normal use, the internal lockout feature of the DM²® Series D double valve must be tested for proper functioning. Observe normal press operation safety precautions during these tests to avoid personal injury or damage to equipment.

Note: Reset may need to be performed prior to beginning the test procedure. Also, both pilot solenoids must be de-energized prior to reset and must remain de-energized until after the reset signal is removed.

A) Electrically energize both pilot solenoids simultaneously, then de-energize one pilot solenoid. This should result in a valve lockout and prevent the valve from operating.

B) Energize both solenoids and the valve should remain in the lockout condition.

C) De-energize both pilot solenoids and reset the valve.

D) Electrically energize both pilot solenoids simultaneously again. De-energize the other pilot solenoid this time. Again, this should result in a lockout.

E) Energize both pilot solenoids. The valve should remain in a lockout condition.

F) De-energize both pilot solenoids and then reset the valve.

After satisfying these tests, energizing both pilot solenoids simultaneously should result in normal operation.

Fault Indication: If fault indication is desired, ROSS offers a status indicator option that can be used to signal to the press controls that a fault has occurred. The status indicator utilizes a pressure switch. The pressure switch has 4 electrical contacts. During normal operation the pressure switch is pressurized. A lockout condition depressurizes the switch until the valve is reset. Contacts 1 and 2 are closed when the switch is depressurized (normally closed) and contacts 1 and 3 are closed when an adequate pressure signal is applied to the switch (normally open).

VALVE OPERATION

On first operation, or after repair, the pilot valve supply circuit and inherent monitoring elements may need to be reset. This reset is accomplished by applying a momentary air signal to the RESET port or by energizing the optional reset solenoid momentarily on the valve. After reset, the valve will then be ready for operation.

The air supply to each pilot valve is controlled by the position of the inlet poppets. In the ready-for-operation position these poppets are held on their seats and maintain pilot air flow. During shifting of the valve elements the poppets move off seat and momentarily allow pilot air to escape to exhaust. If either valve element fails to operate correctly, the pilot supply to the other valve element will remain connected to exhaust causing the valve to lock-out.

The internal monitoring system will lock out the valve if the time difference between both elements shifting fully is longer than approximately 125 milliseconds. This timing is preset by restricting-orifices and chambers in the pilot air circuit.

The main airflow from port 1 to port 2 is via crossflow passages between both main valves, so that both valve elements must be fully shifted in order for port 2 to be pressurized.

If the valve locks out, further operation is prevented until the valve has been reset. Electrical signals to the solenoids must be "off" to allow the valve to be reset.

The DM²® Series D double valve is completely self-contained and does not need an external monitoring system.

VALVE RESET INFORMATION

When and why does the valve require a reset signal?

The valve will only require a reset when the valve has detected asynchronous movement of the two independent internal elements. This condition will be indicated by a fault signal from the Status Indicator and an audible leak from the silencer. For solenoid reset models, reset is accomplished by applying a momentary signal to the reset solenoid. For air reset models, reset is accomplished by applying a momentary air signal to the reset port. The DM²⁰⁰ Series D double valves have an anti-tie-down feature that requires both main valve solenoids to be de-energized while resetting.

Why will my valve not reset?

There are a few common conditions that can prevent reset from occurring.

1. If the main valve solenoids are energized the valve will not reset. This is a safety feature of the DM²⁰⁰ Series double valves that prevents unintended pressure output from occurring upon valve reset. There should be at least a 200 ms delay between removing power from the reset solenoid and applying power to the main valve solenoids.

2. If the pneumatic supply to port 1 is not sufficient the valve will not reset. This is not unusual for initial testing and startup if full plant pressure and volume is not applied and quick connects or small hoses are used.
3. If the supply pressure was removed before de-energizing the valve it is possible that both valve elements are in the faulted condition. This condition results in a greater leakage rate to the exhaust port when the supply is reapplied, and increases the insufficient supply issue mentioned in item #2.
4. The reset solenoid may be mounted backwards. In this case energizing the reset solenoid will result in the release of air through the reset solenoid's exhaust port (through the nut mounted on the stem of the solenoid) and no reset action can occur.

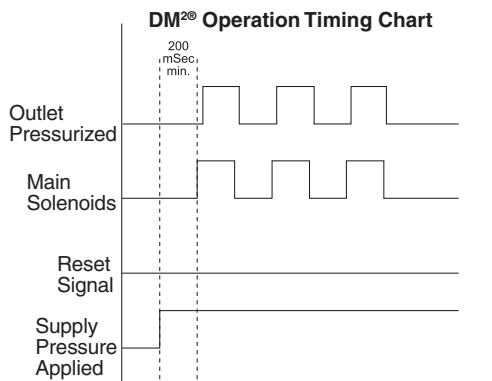

1. Operating signal to main solenoids should be dual channel, concurrent operation. Discordance of signals should be less than 25 msec.
2. Turning off supply pressure while valve is energized will result in a fault and then valve must be reset.
3. Fault detection is constant.

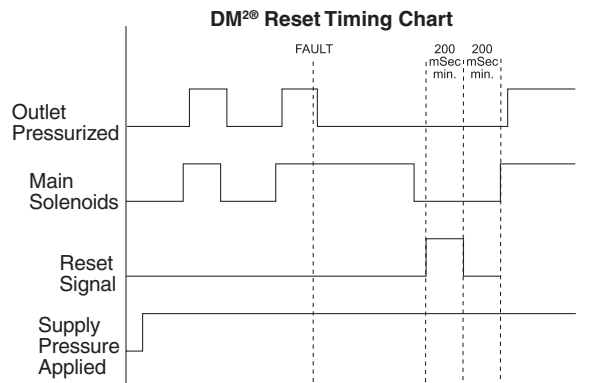

1. Reset anti-tie-down feature requires main solenoids to be off during reset.
2. Reset duration is momentary - 200 msec. min. recommended.
3. At end of reset signal, time is required for pilot chambers to refill before operation - 200 msec. recommended.
4. Fault detection is constant.
5. Turning off supply pressure while valve is energized will result in a fault and then valve must be reset.

VALVE MAINTENANCE

Pneumatic equipment should be maintained only by persons trained and experienced in the maintenance of such equipment.

Supply Clean Air. Foreign material lodging in valves is a major cause of breakdowns. The use of a 5-micron-rated air filter located close to the valve is strongly recommended. The filter bowl should be drained regularly, and if its location makes draining difficult, the filter should be equipped with an automatic drain.

Check Lubricator Supply Rate. A lubricator should put a fine oil mist into the air line in direct proportion to the rate of air flow. Excessive lubrication can cause puddling in the valve and lead to malfunctions. For most applications an oil flow rate in the lubricator of one drop per minute is adequate. *Note that the double valve itself does not require air line lubrication.*

Compatible Lubricants. Although this valve does not require air line lubrication, it may be used with lubricated air being supplied to other mechanisms. Some oils contain additives that can harm seals or other valve components and so cause the valve to malfunction. Avoid oils with phosphate additives (e.g., zinc dithiophosphate) and diester oils; both types can harm valve components. The best oils to use are generally petroleum base oils with oxidation inhibitors, an aniline point between 180°F (82°C) and 220°F (104°C), and an ISO 32 or lighter viscosity.

Some compatible oils are listed above at the right. These oils, although believed to be compatible, could change without notice because manufacturers sometimes reformulate their oils. Therefore, use oils specifically compounded for air line service. If it is a synthetic oil, contact the oil manufacturer for compatibility information.

Cleaning the Valve. If the air supplied to the valve has not been well filtered, the interior of the valve may accumulate dirt and varnish which can affect the valve's performance. A schedule should be established for cleaning all valves, the frequency depending on the cleanliness of the air being supplied.

COMPATIBLE LUBRICANTS

Maker	Brand Name
Amoco	American Industrial Oil 32
.....	Amoco Spindle Oil C, Amolite 32
Citgo	Pacemaker 32
Exxon	Spinesstic 22, Teresstic 32
Mobil.....	Velocite 10
Non-Fluid Oil	Air Lube 10H/NR
Shell	Turbo T32
Sun.....	Sunvis 11, Sunvis 722
Texaco.....	Regal R&O 32
Union.....	Union Turbine Oil

To clean the valve, use any good commercial solvent. Do *not* scrape varnished surfaces. Also, do not use chlorinated solvents or abrasive materials. The former damages seals, and abrasives can do permanent damage to metal parts. Before reassembling the valve, lubricate all sliding surfaces with a grease such as Dow Corning BR 2 Plus.

Electrical Contacts. In the electrical circuits associated with the valve solenoids, keep all switches or relay contacts in good condition to avoid solenoid malfunctions.

Replace Worn Components. In most cases it is not necessary to remove the valve from its installation for servicing. However, turn off the electrical power to the valve, shut off the air supply, exhaust the air in the system, and lock-out before beginning any disassembly operation. Service kits are listed on page 3.

If you have any questions about installing or servicing your valve, call ROSS Technical Services at your nearest ROSS location (see page 4) or in the U.S.A. at: 1-888-TEK-ROSS(835-7677).

STANDARD SPECIFICATIONS

Construction Design	Dual poppet	Operating Pressure	Basic Size 2: 45 to 150 psig (3.1 to 10.3 bar) Basic Size 4, 8, 12, 30: 30 to 120 psig (2.1 to 8.3 bar)
Mounting	Type: Base Orientation: Preferably horizontally (valve on top of base) or vertically (with pilot solenoids on top)	Reset Pressure	For remote air reset option – must be equal to inlet pressure
Solenoids	According to VDE 0580. Two solenoids, rated for continuous duty	Manual Pressure	Encapsulated, push button actuation
Voltage	24 Volts DC; 110 volts, 50 Hz, 120 volts, 50/60 Hz; 230 volts AC, 50/60 Hz	Pressure Switch (Status Indicator) Rating	NO, NC Contacts 0.1 A, 125/250 volts AC; 0.1 A, 30 volts DC; 0.3 A, 60 volts DC
Power Consumption (each solenoid)	Basic Size 2, 4, 12, 30: Primary and reset solenoids: 5.8 watts nominal on AC and DC; 6.5 watts maximum on AC and DC Basic Size 8: Primary solenoid: 15 watts on DC; 36 VA inrush and 24.6 VA holding on 110/120 Volts AC; 32 VA inrush and 22 VA holding on 230 Volts AC Reset solenoid: 5.8 watts nominal, 6.5 watts maximum	Solid State Pressure Sensor (Status Indicator) Rating	8-30 volts DC <4mA
Enclosure Rating	DIN 40050, IP65, IEC 60529	Monitoring	Dynamically, cyclically, internally during each actuating and de-actuating movement. Monitoring function has memory and requires an overt act to reset unit after lockout.
Electrical Connection	Connector socket according to EN 175301-803 Form A, M12	Operation Frequency	Minimum once per month, to ensure proper function
Temperature	Ambient: 15° to 122°F (-10° to 50°C) Media: 40° to 175°F (4° to 80°C)	Construction Material	Valve Body: Cast Aluminum Poppet: Acetal and Stainless Steel Seals: Buna-N
Flow Media	Filtered, lubricated or unlubricated (mineral oils according to DIN 51519, viscosity classes 32-46)	Functional Safety Data: Category 4, PL e; B _{10D} : 20,000,000; PFH _D : 7.71x10 ⁻⁹ ; MTTFD: 301.9 (n _{op} : 662400).	Certifications: CE Marked for applicable directives, DGUV, CSA/UL, TSSA for appropriately tested valves Vibration/Impact Resistance: Tested to BS EN 60068-2-27.

IMPORTANT NOTE: Please read carefully and thoroughly all the **CAUTIONS** and **WARNINGS** on page 4.

VALVE SERVICE

ROSS would be happy to service this valve for you at its factory repair center. If you purchased your valve from ROSS please contact ROSS customer service, if you purchased your valve thru an authorized ROSS distributor please contact the distributor for return instructions. However, if you choose to service this valve yourself, it is strongly recommended that you visit our website at www.rosscontrols.com for available downloadable technical documentation.

When servicing the valve yourself, be sure to turn off electrical power to the valve, shut off the air supply, exhaust the air in the system, and lock-out all power sources before beginning any disassembly operation. Listed below are kits for servicing DM[®] Series D double valves, as well as replacement solenoid information.

CAUTION: Before operating the DM[®] Series D double valve, be sure to complete the test procedure (TEST), on page 1, upon installation and after any maintenance is performed on the valve. Failure to do so could result in personal injury or equipment damage.

Valve Body Service Kits. These kits contain all parts needed for complete reconditioning of a valve body. Included are poppets, spindles, gaskets, seals, and instructions for use.

Status Indicator Assembly Service Kit. This kit includes all parts needed for complete reconditioning of the status indicator assembly. Pressure switch and connector sold separately.

Pilot Booster Service Kits. Available for sizes 12 and 30, these kits contain all parts needed for complete reconditioning of a pilot booster. Included are poppets, gaskets, seals, and instructions for use.

Replacement Pressure Switch. This kit includes a replacement pressure switch and electrical connector for the status indicator assembly.

Solenoid Coils. Order replacement by part number provided at the right. For other voltages, consult ROSS.

Complete Solenoid Pilot Assemblies. These assemblies consist of new pilot valve mechanisms and a new solenoid coil, ready to bolt in position on the valve. For other voltages, consult ROSS.

For wiring kits and accessories, please see product web page or product literature at www.rosscontrols.com.

Replacement Solenoid Coils				
Basic Size	Solenoid Coil Type	Model Number		
		Voltage		
		24 volts DC	110 or 120 volts AC	230 volts AC
2, 4, 12, 30	Pilot	411B3316	411B33105	411B33177
8	Pilot	360K3316	360K33105	360K33107
All Sizes	Reset	411B3316	411B33105	411B33177

Complete Solenoid Pilot Assemblies				
Basic Size	Solenoid Coil Type	Model Number		
		Voltage		
		24 volts DC	110 or 120 volts AC	230 volts AC
2	Pilot	1520C7916	1520C79105	1520C79177
4	Pilot	1403H7916	1403H79105	1403H79167
8	Pilot	1404H7916	1404H79105	1404H79107
12 & 30	Pilot	1526C7916	1526C79105	1526C79177
All Sizes	Reset	1524C7916	1524C79105	1524C79177

Service Kits				
Basic Size	Valve Body Service Kit Number	Status Indicator Assembly Service Kit Number	Pilot Booster Service Kit Number	Replacement Pressure Switch Kit Number
2	2101K77	2151H77	-	1104A30
4	2102K77			
8	2103K77			
12	2104K77	2151H77	2106K77	
30	2105K77			



CAUTIONS And WARNINGS



ROSS OPERATING VALVE, ROSS CONTROLS®, ROSS DECCO®, and AUTOMATIC VALVE INDUSTRIAL, collectively the “ROSS Global Family”.

PRE-INSTALLATION or SERVICE

1. Before servicing a valve or other pneumatic component, be sure all sources of energy are turned off, the entire pneumatic system is shut down and exhausted, and all power sources are locked out (ref: OSHA 1910.147, EN 1037).
2. All ROSS Global Family Products, including service kits and parts, should be installed and/or serviced only by persons having training and experience with pneumatic equipment. Because any product can be tampered with and/or need servicing after installation, persons responsible for the safety of others or the care of equipment must check ROSS Global Family Products on a regular basis and perform all necessary maintenance to ensure safe operating conditions.
3. All applicable instructions should be read and complied with before using any fluid power system to prevent harm to persons or equipment. In addition, overhauled or serviced valves must be functionally tested prior to installation and use. If you have any questions, call your nearest ROSS Global Family location.
4. Each ROSS Global Family Product should be used within its specification limits. In addition, use only ROSS Group components to repair ROSS Global Family Products.

WARNINGS: Failure to follow these instructions can result in personal injury and/or property damage.

FILTRATION and LUBRICATION

1. Dirt, scale, moisture, etc., are present in virtually every air system. Although some valves are more tolerant of these contaminants than others, best performance will be realized if a filter is installed to clean the air supply, thus preventing contaminants from interfering with the proper performance of the equipment. The ROSS Global Family recommends a filter with a 5-micron rating for normal applications.
2. All standard ROSS Global Family filters and lubricators with polycarbonate plastic bowls are designed for compressed air applications only. Use the metal bowl guard, where provided, to minimize danger from high pressure fragmentation in the event of bowl failure. Do not expose these products to certain fluids, such as alcohol or liquefied petroleum gas, as they can cause bowls to rupture, creating a combustible condition and hazardous leakage. Immediately replace crazed, cracked, or deteriorated bowls.
3. Only use lubricants which are compatible with materials used in the valves and other components in the system. Normally, compatible lubricants are petroleum base oils with oxidation inhibitors, an aniline point between 180°F (82°C) and

220°F (104°C), and an ISO 32, or lighter, viscosity. Avoid oils with phosphate type additives which can harm polyurethane components, potentially leading to valve failure which risks personal injury, and/or damage to property.

WARNINGS: Failure to follow these instructions can result in personal injury and/or property damage.

AVOID INTAKE/EXHAUST RESTRICTION

1. Do not restrict air flow in the supply line. To do so could reduce the pressure of the supply air below minimum requirements for the valve and thereby causing erratic action.
2. Do not restrict a valve's exhaust port as this can adversely affect its operation. Exhaust silencers must be resistant to clogging and must have flow capacities at least as great as the exhaust capacities of the valves. Contamination of the silencer can result in reduced flow and increased back pressure.

WARNINGS: Failure to follow these instructions can result in personal injury and/or property damage.

SAFETY APPLICATIONS

1. Mechanical Power Presses and other potentially hazardous machinery using a pneumatically controlled clutch and brake mechanism must use a press control double valve with a monitoring device. A double valve without a self-contained monitoring device should be used only in conjunction with a control system which assures monitoring of the valve. All double valve installations involving hazardous applications should incorporate a monitoring system which inhibits further operation of the valve and machine in the event of a failure within the valve mechanism.
2. Safe Exhaust (dump) valves without a self-contained monitoring device should be used only in conjunction with a control system which assures monitoring of the valve. All Safe Exhaust valve installations should incorporate a monitoring system which inhibits further operation of the valve and machine in the event of a failure within the valve mechanism.
3. Per specifications and regulations, the ROSS L-O-X® and L-O-X® with EEZ-ON®, N06 and N16 Series operation products are defined as energy isolation devices, NOT AS EMERGENCY STOP DEVICES.

WARNINGS: Failure to follow these instructions can result in personal injury and/or property damage.

STANDARD WARRANTY

All products sold by the ROSS Global Family are warranted for a one-year period [with the exception of Filters, Regulators and Lubricators (“FRLs”) which are warranted for a period of seven (7) years] from the date of purchase. All products are, during their respective warranty periods, warranted to be free of defects in material and workmanship. The ROSS Global Family's obligation under this warranty is limited to repair, replacement or refund of the purchase price paid for products which the ROSS Global Family has determined, in its sole discretion, are defective. All warranties become void if a product has been subject to misuse, misapplication, improper maintenance, modification or tampering. Products for which warranty protection is sought must be returned to the ROSS Global Family freight prepaid.

THE WARRANTY EXPRESSED ABOVE IS IN LIEU OF AND EXCLUSIVE OF ALL OTHER WARRANTIES AND THE ROSS GLOBAL FAMILY EXPRESSLY DISCLAIMS ALL OTHER WARRANTIES EITHER EXPRESSED OR IMPLIED WITH RESPECT TO MERCHANTABILITY OR FITNESS FOR A PARTICULAR PURPOSE. THE ROSS GLOBAL FAMILY MAKES NO WARRANTY WITH RESPECT TO ITS PRODUCTS MEETING THE PROVISIONS OF ANY GOVERNMENTAL OCCUPATIONAL SAFETY AND/OR HEALTH LAWS OR REGULATIONS. IN NO EVENT IS THE ROSS GLOBAL FAMILY LIABLE TO PURCHASER, USER, THEIR EMPLOYEES OR OTHERS FOR INCIDENTAL OR CONSEQUENTIAL DAMAGES WHICH MAY RESULT FROM A BREACH OF THE WARRANTY DESCRIBED ABOVE OR THE USE OR MISUSE OF THE PRODUCTS. NO STATEMENT OF ANY REPRESENTATIVE OR EMPLOYEE OF THE ROSS GLOBAL FAMILY MAY EXTEND THE LIABILITY OF THE ROSS GLOBAL FAMILY AS SET FORTH HEREIN.

AMERICAS	USA	ROSS CONTROLS	Tel: +1-248-764-1800	www.rosscontrols.com
	Brazil	ROSS DO BRASIL LTDA	Tel: +55-11-4335-2200	www.rosscontrols.com.br
	Canada	ROSS CANADA Inc.	Tel: +1-416-251-7677	www.rosscanada.com
EUROPE	France	ROSS FRANCE SAS	Tel: +33-(0)1-49-45-65-65	www.rossfrance.com
	Germany	ROSS EUROPA GmbH manufactIS GmbH	Tel: +49 (0)6103-7597-100 Tel: +49 (0)2013-16843-0	www.rosseuropa.com www.manufactis.net
	United Kingdom	ROSS PNEUMATROL Ltd.	Tel: +44 (0)1254 872277	www.rossuk.co.uk
ASIA & PACIFIC	China	ROSS CONTROLS (CHINA) Ltd.	Tel: +86-21-6915-7961	www.rosscontrolschina.com
	India	ROSS CONTROLS INDIA Pvt. Ltd.	Tel: +91-44-2624-9040	www.rosscontrolsindia.com
	Japan	ROSS ASIA K.K.	Tel: +81-42-778-7251	www.rossasia.co.jp