

PATLITE®



NE-24A



NE-M1A



NE-IL

Notice to Customer

Thank you very much for purchasing our PATLITE products.

- Request the installation and wiring be performed by a professional contractor if construction work is involved.
- Prior to installation, read this manual thoroughly before using this product to ensure correct use.
- If there are any questions concerning this product, refer to the contact information at the end of this document and contact your nearest PATLITE Sales Representative.

To the Contractor

- Read this manual carefully prior to installation.
- Be sure to return this manual to the customer.

Signal Beacon

TYPE NE-24A/NE-M1A

☑ IO-Link Signal Beacon

TYPE NE-IL

Complete Operation Manual

Installation

Operation

Maintenance

	Page
1 Read this First	2
2 Model Number Configuration	3
3 Names and Dimensions	6
4 Installation	10
5 Wiring	13
6 Using the LED and Buzzer	18
7 Troubleshooting	27
8 Specifications	30
9 Service Parts	33
10 Optional Parts	34

1 Read this First

Safety Precautions

The safety precautions that should always be followed in order to prevent injury to user or other individuals as well as prevent damage to property are described below.

■ The level of injury or damage caused by ignoring these safety precautions and using the product improperly is categorized and described below.

Warning

This icon indicates an action with the potential to cause death or serious injury.

Caution

This icon indicates an action with the potential to cause injury, physical loss or damage.

Warning

- To prevent from short-circuits or damage, observe the following:
 - Be sure the power is disconnected before replacement or repair, including the replacement of the fuse.
 - Use this product in a properly maintained condition. (Replace or repair if the globe, case, etc. are damaged.)
- If installing this product requires construction work, ask a specialist in order to avoid fire, or personal injury.
- When this product is used for security purposes, it should be inspected daily. In case a malfunction should occur, it is recommended that you use this product together with other security products.
- After installation, do not use this product to climb up onto the equipment with.
Failure to comply will result in product damage and/or falling off the machinery.

Caution

- Be sure to put a fuse in the wiring circuit between the power source and equipment for protection. If a fuse is not added, it may result in product and/or equipment failure.
- Be sure to prevent electrostatic damage due to discharge when working with this product for wiring, exchanging units, setting up parameters, etc. by discharging static electricity on your body, etc.
- Do not disassemble or detach during operation.
- Do not push on any internal parts when wiring or removing and installing the globe.

Notice

- To ensure proper safety while using the signal tower, observe the following:
 - Perform **periodic pre-maintenance**.
 - As a precaution against problems occurring, **use this product together with other equipment**.
- **Be sure to prevent electrostatic damage** due to discharge when working with this product for wiring, exchanging units, setting up parameters, etc. by discharging static electricity on your body, etc.
(To prevent damage from static electricity, touch hands or other body parts to metals or an earth ground to discharge the body from static charge.)
- Use a soft cloth moistened with water to clean the globe or case.
(Do not use **thinner, benzine, gasoline or oil**.)
- To ensure safety when this product is installed onto equipment, observe the following:
 - **Do not remove parts** beyond those designed to be removed from this product.
 - **Do not modify or disassemble** this product.
 - Use only the specified replacement parts listed in this document.

2 Model Number Configuration

TYPE NE-24A

	Model		Rated Voltage		Luminous Color
Assembly Model	NE	-	↓	A-	↓
			24 24 V DC		R Red Y Amber G Green B Blue C White

Model Number Example **NE-24A-R**

- 24 V DC
- Red

TYPE NE-M1A

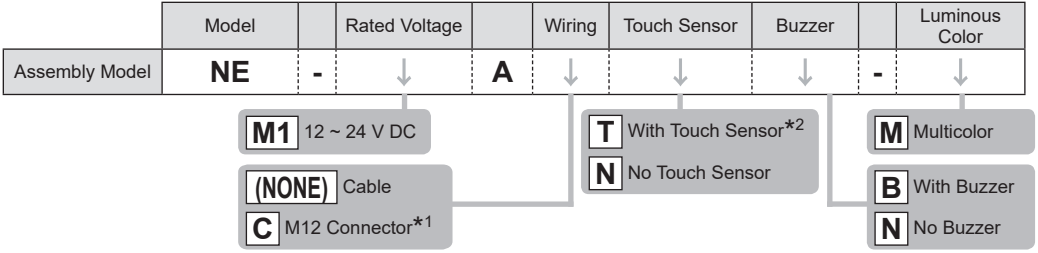

*1 **NE** - **M1 A C N B** only

*2 **NE** - **M1 A T B** only

Model Number Example

NE-M1ATB-M

- 12 ~ 24 V DC
- Touch Sensor
- Buzzer
- Multicolor

TYPE NE-IL

	Model			Touch Sensor	Buzzer		Luminous Color
Assembly Model	NE	-	IL	↓	↓	-	↓

X With Touch Sensor (General-Purpose Digital/Analog Input)*

T With Touch Sensor

N No Touch Sensor

B With Buzzer

N No Buzzer

M Multicolor

* **NE** - **IL** **X** **B** only

Model Number Example

NE-ILXB-M

- IO-Link
- Touch Sensor (General-Purpose Digital/Analog Input)
- Buzzer
- Multicolor

3 Names and Dimensions

TYPE NE-24A

Unit: mm

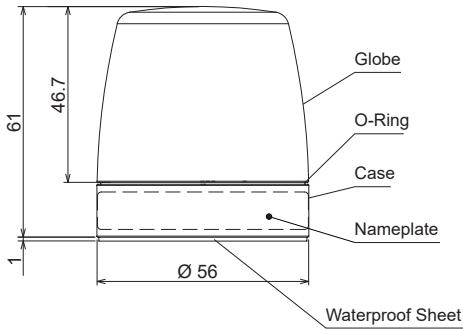

Accessory
Waterproof Sheet

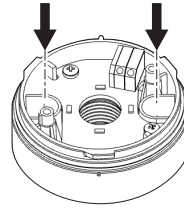
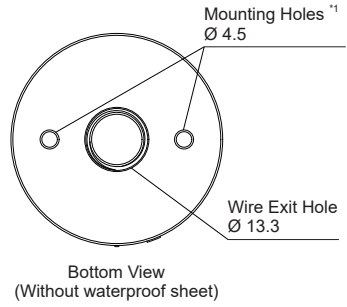

*1 The mounting holes (2 positions) are designed to be punched out.
Drill the $\varnothing 4.5$ mounting holes from the top.

TYPE NE-M1A

Unit: mm

NE-M1ANN-M

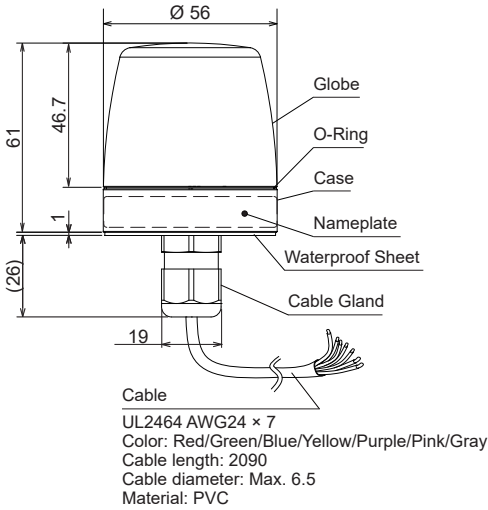

NE-M1ATB-M/NE-M1ANB-M

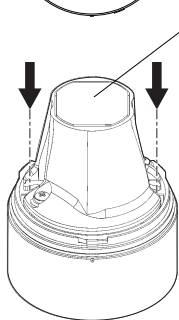
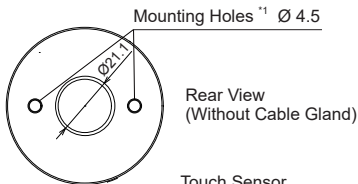
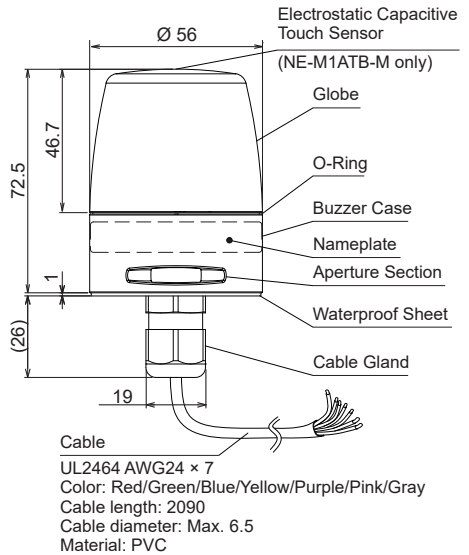

*1 The mounting holes (2 positions) are designed to be punched out.
 Drill the $\varnothing 4.5$ mounting holes from the top.
 When drilling out the holes, take care to prevent the tools from making contact with the internal touch sensor.

Accessory
Waterproof Sheet

Unit: mm

NE-M1ACNB-M

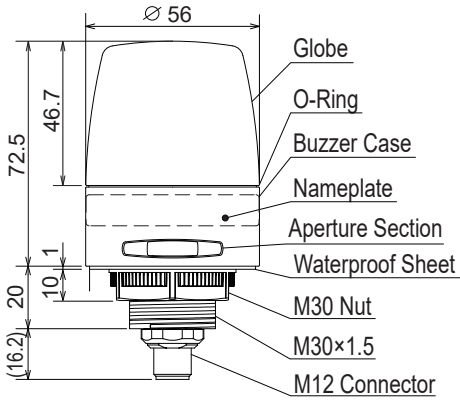

M12 Connector Pin Configuration

- NE-M1ACNB-M
5-pin male (plug)

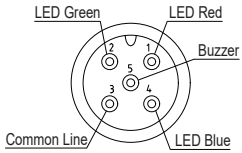

TYPE NE-IL

Unit: mm

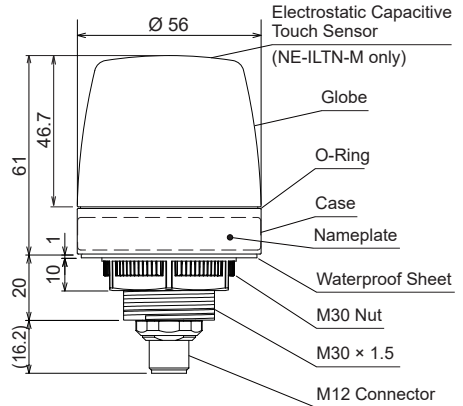
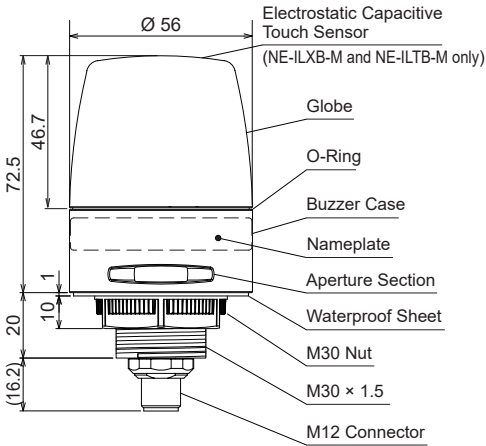

M12 Connector Pin Configuration

■ NE-ILXB-M

8-pin male (plug)

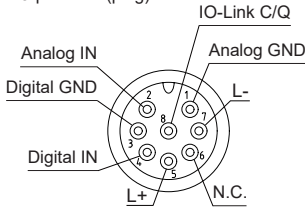

■ NE-ILNN-M/NE-LNB-M/NE-ILTN-M/NE-ILTB-M

5-pin male (plug)

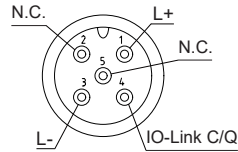

4 Installation

⚠ Caution

- This product is for indoor use only. (Do not use it outdoors.)
- Do not leave the product, or use it without globe installed.
- Do not apply excessive force when mounting/removing the globe. Failure to comply will result in damage.
- When removing and installing the globe again, check that there is no gap between the globe and case. A gap may result in parts falling in or water ingress.
- Use a soft cloth moistened with water to clean the globe or case. (Do not use thinner, benzine, gasoline or oil.)
- The waterproof sheet must be used before installation.
- This product has a 1mm thick waterproof sheet at the bottom of the case. However, because installation surface unevenness may cause a lack of waterproofing protection, it is recommended to apply sealant between the unit and the installation surface to maintain waterproof conditions.

Notice

- The following requirements are necessary for proper installation:
 - Install the signal beacon where excessive **vibration** is not present.
 - Install the signal beacon on a **sturdy** surface.
 - Install the signal beacon on a **level** surface.
- When waterproofing, apply a sealing coating onto the nuts on the backside of the installation surface. Provide a sealant coating around the wire exit hole, or use a Cable Gland.

TYPE NE-24A

- (1) Unlock the globe by holding and rotating it in a counter-clockwise direction, then lift it up.
- (2) Punch-out the mounting holes on the case by drilling $\varnothing 4.5$ holes from the top.
- (3) Peel off the adhesive paper from the waterproof sheet and apply it to the case.
- (4) Affix the product to the installation surface with screws and nuts. (Installation screws and nuts are not included with this product.)
- (5) After mounting the case, fit the globe by aligning the positioning marks and lock it by rotating in a clockwise.

■ Installation Dimension [Unit: mm]

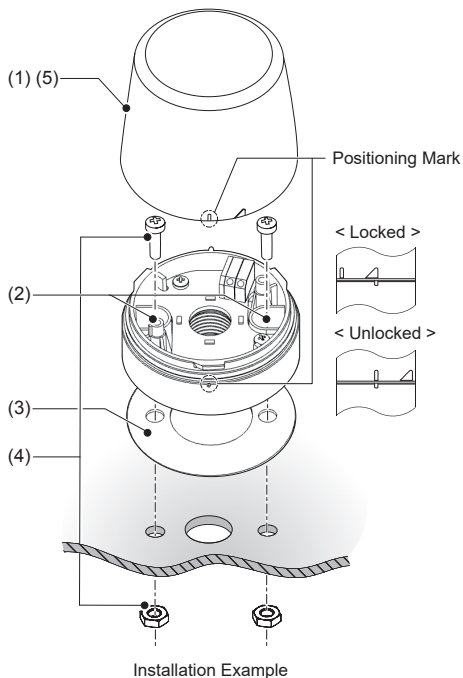
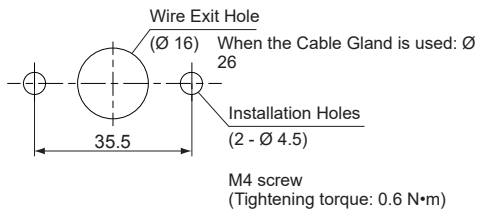

* When the Cable Gland is used, the hole must be large enough for it to fit through.

The recommended Cable Gland size is as follows:

- screw size: M16 \times 1.5; screw length: shorter than 11 mm;
- outer diameter: less than 25 mm;
- material: plastic. (Tightening torque : 3 N·m)

TYPE NE-M1A

- (1) Remove the globe by unscrewing it in a counter-clockwise direction.
- (2) Punch-out the mounting holes on the case and buzzer case by drilling holes from the top.
- (3) Peel off the adhesive paper from the waterproof sheet and apply it to the case.
- (4) Affix the product to the installation surface with screws and nuts. (Installation screws and nuts are not included with this product.)
- (5) Set the globe with aligning the positioning mark after attaching the case, then turn the globe clockwise to lock it.

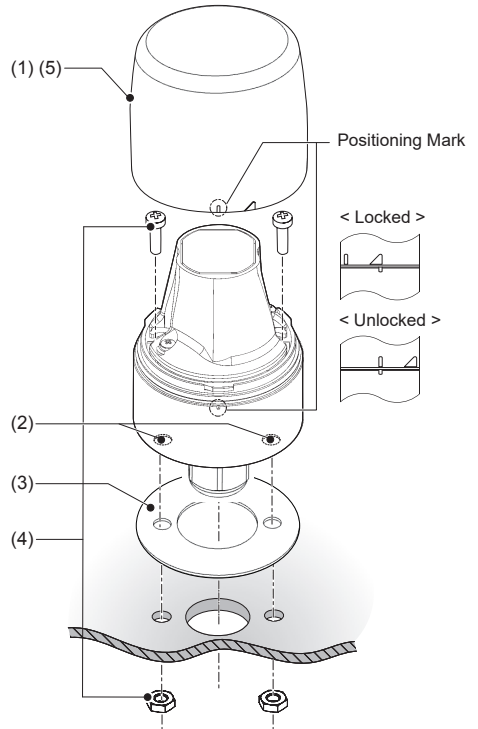

Installation Example

■ Installation Dimension [Unit: mm]

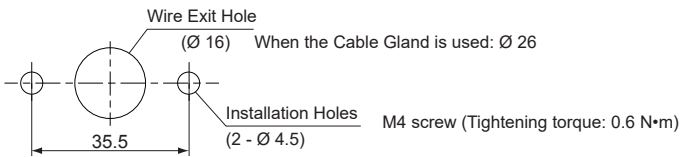

TYPE NE-IL/NE-M1ACNB

- (1) Remove the M30 nut.
- (2) Fix on the mounting surface with the M30 nut.
- (3) Connect the M12 cable to the M12 Connector.

<NE-IL□B-M/NE-M1ACNB-M Model>

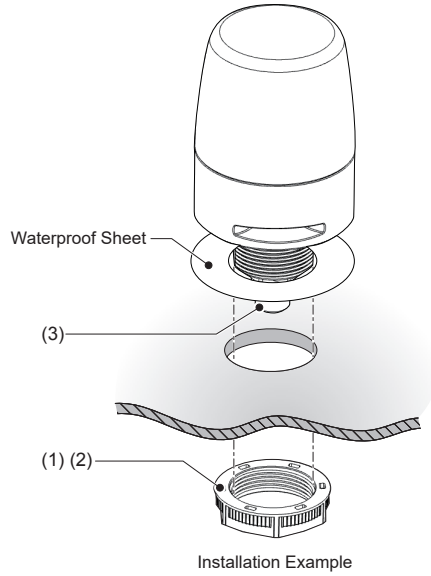

■ Installation Dimension [Unit: mm]

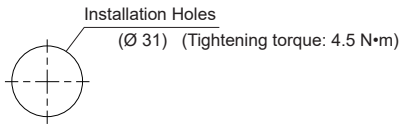

5 Wiring

⚠ Caution

- Make sure the power is OFF before wiring. A short circuit may damage internal circuits.
- Ensure the proper working voltage is used. Improper voltage will damage internal circuits.
- When wiring, do not pull on the wires or force them into the buzzer housing.
- Be sure the wiring is done properly. Any mistake in wiring may result in damage.
- Be sure to put a fuse in the wiring circuit between the power source and equipment for protection. If a fuse is not added, it may result in product and/or equipment failure.

TYPE NE-24A

- (1) Remove the globe by unscrewing it in a counter-clockwise direction.
 - (2) Connect the wires to the screwless terminal block.
 - (3) Attach the globe by screwing it in a clockwise direction.
- * The terminals have no polarity.

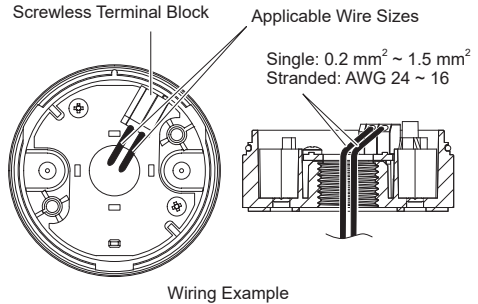

Screwless Terminal Block wiring method

- (1) A minus driver etc. is used to pry the lever slot of the Terminal Block open, by pushing straight onto the lever slot.
 - (2) The stripped side of the lead wire is inserted in the slot.
 - (3) The driver is removed to release the lever. (Check to make sure the lead wire has been locked in place.)
- Strip 8 mm of wire insulation from the wire to insert it in the Terminal Block.
 - The minus driver blade should be at about 2 mm by 0.5 mm in size.

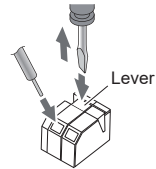

⚠ Caution

- Do not apply excess force to the screwless terminal block during wiring. Doing so may cause damage.

Notice

- Make sure that there is no slack in the internal wiring. Wiring hanging over the LED may cause a reduction in luminous intensity.

TYPE NE-24A

Wiring examples vary depending on the driving method.

(A) External Contact Drive

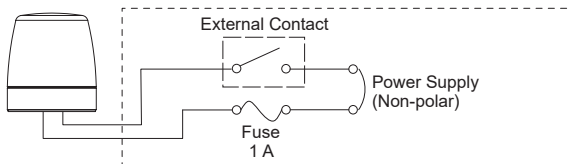

(B) I/O Unit Drive
(NPN Transistor)

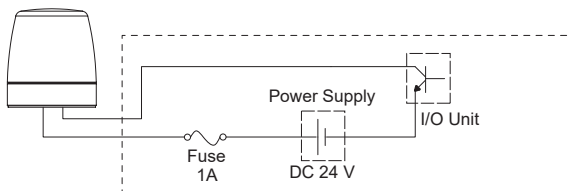

(C) I/O Unit Drive
(PNP Transistor)

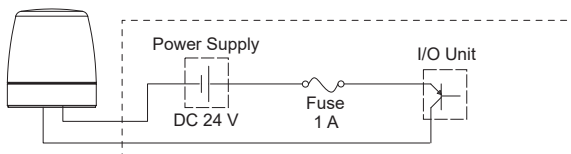

[Fuse]

Fuse Rating	250 V 1 A
--------------------	-----------

[External Contact Capacity]

Current Capacity	$I_s \geq 50 \text{ mA}$
Voltage Capacity	$V_s \geq 35 \text{ V}$

[Transistor (NPN or PNP)]

Current Capacity	$I_c \geq 50 \text{ mA}$
Withstand Voltage	$V_c \geq 35 \text{ V}$
Leakage Current	$I_L \leq 0.1 \text{ mA}$

* No significant inrush current present.

TYPE NE-M1A

NE-M1ANN-M/NE-M1ANB-M

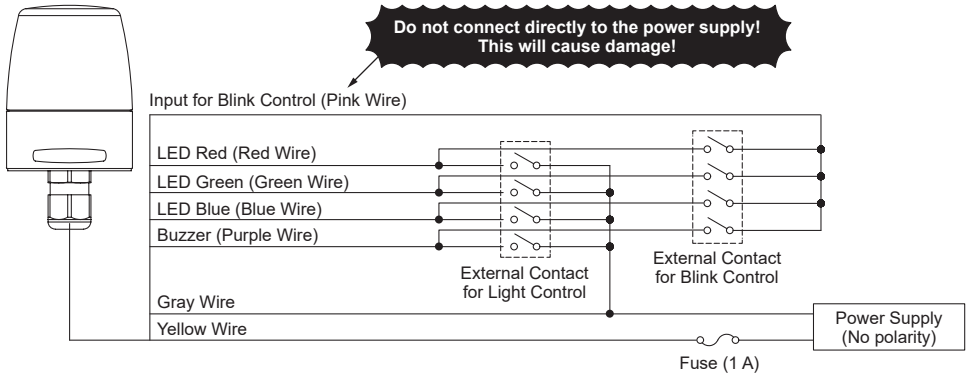

NE-M1ATB-M

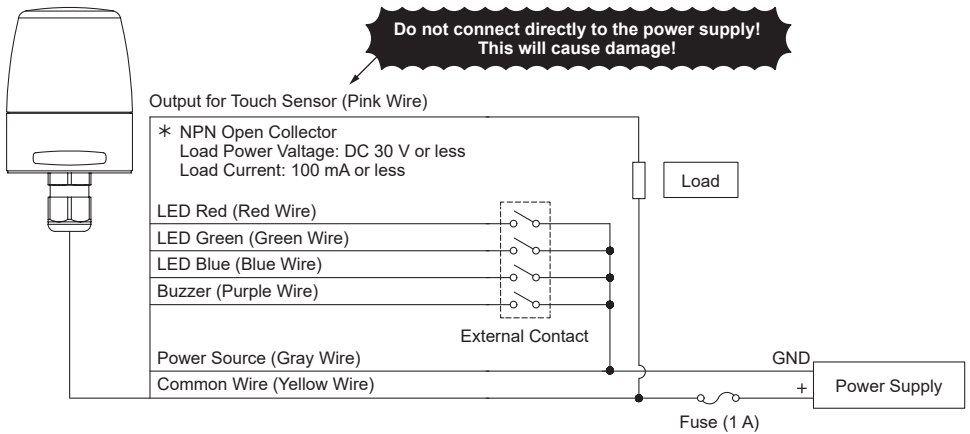

LED Color	Red	Green	Blue	Yellow	Cyan	Purple	White
Wiring	Red	Green	Blue	Red + Green	Blue + Green	Red + Blue	Red + Green + Blue

< NOTE > No need to connect the buzzer (purple wire) for NE-M1ANN-M. When the blink control is not necessary for NE-M1ANN-M/NE-M1ANB-M, no need to connect the blink control (pink wire). Be sure to insulate all unconnected lead wires one by one. Otherwise, electric shock or short circuit may occur.

[Fuse]

Fuse Rating	250 V 1 A
-------------	-----------

[External Contact Capacity]

Current Capacity	$I_s \geq 50 \text{ mA}$
Voltage Capacity	$V_s \geq 35 \text{ V}$
Leakage Current	$I_L \leq 0.1 \text{ mA}$

* Inrush current: 0.4A /2msec

* Signal response time: 50 ms

NE-M1ACNB-M

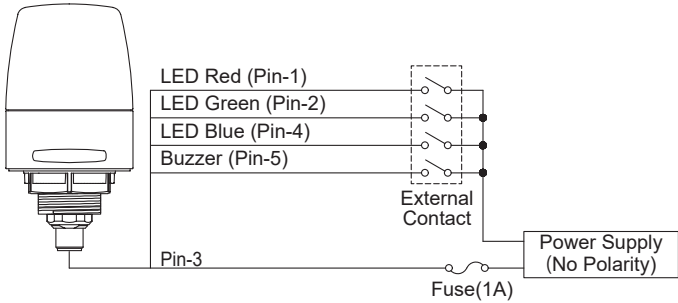

LED Color	Red	Green	Blue	Yellow	Cyan	Purple	White
Pin No.	1	2	4	1 + 2	2 + 4	1 + 4	1 + 2 + 4

< NOTE > Be sure to insulate all unconnected lead wires one by one. Otherwise, electric shock or short circuit may occur.

[Fuse]

Fuse Rating	250 V 1 A
--------------------	-----------

[External Contact Capacity]

Current Capacity	$I_s \geq 50 \text{ mA}$
Voltage Capacity	$V_s \geq 35 \text{ V}$
Leakage Current	$I_L \leq 0.1 \text{ mA}$

- * Inrush current: 15 A / 0.1 ms
- * Signal response time: 50 ms

TYPE NE-IL

NE-ILXB-M

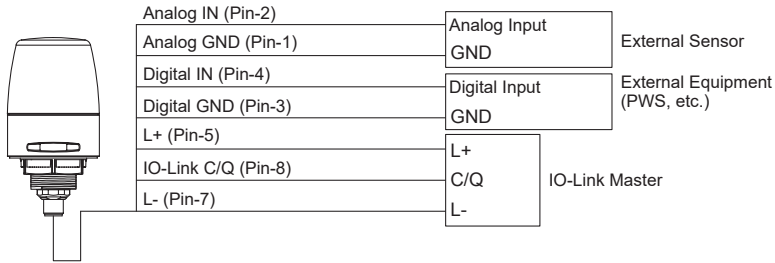

[External Contact Capacity]

Current Capacity	$I_s \geq 50 \text{ mA}$
Voltage Capacity	$V_s \geq 35 \text{ V}$
Leakage Current	$I_L \leq 0.1 \text{ mA}$

[Analog Input]

Input Range	4 mA - 20 mA
--------------------	--------------

* Update interval: 20 ms

[Digital Input]

Driving Method	NPN open drain
-----------------------	----------------

* Update interval: 20 ms

NE-ILNN-M/NE-ILNB-M/NE-ILTN-M/NE-ILTB-M

<NE-IL□B-M Model>

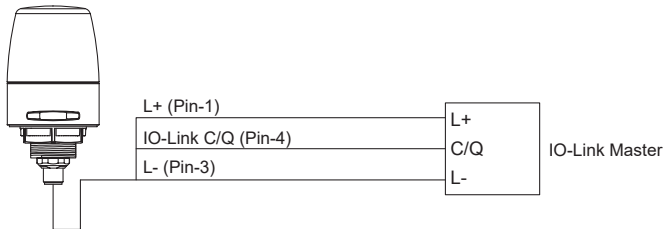

6 Using the LED and Buzzer

TYPE NE-M1A

The LED light color and buzzer sound pattern can be set by removing the globe and adjusting the DIP switches. For touch sensor specifications, the touch sensor input switching can be set.

⚠ Caution

- **Do not use excess force when performing operations.** Failure to comply will result in damage due to breakage or deformation.
- **Do not use sharp-pointed objects to perform operations.** Failure to comply may result in damage and inoperative switches or hinder contact between contact parts.

Top view of product (with globe removed)

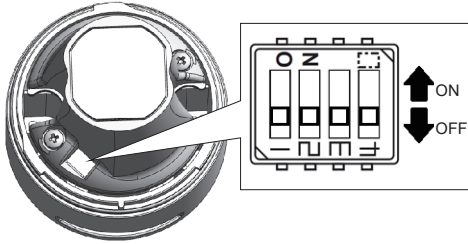

Using the NE-M1A

This product is able to use a signal wire to control the LED and buzzer. Each setting is adjusted using the setting DIP switches. NE-M1ATB can also be controlled with a touch sensor.

■ About DIP Switches

Settings can be changed as shown in the following tables. (All OFF as factory default settings)

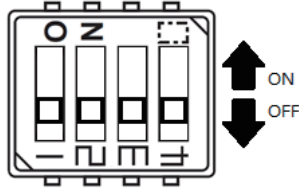

NE-M1ATB	Switch 1	Switch 2	Switch 3	Switch 4
Function	Buzzer Pattern Settings	Change Touch Sensor Input Settings	Change Touch Sensor Input LED Color Settings	

NE-M1ANB NE-M1ACNB	Switch 1	Switch 2	Switch 3	Switch 4
Function	Buzzer Pattern Settings	Not used	Not used	Not used

■ Buzzer Pattern Settings

Change the buzzer pattern as shown in the following table.

Switch Position	OFF	ON
Buzzer Pattern	Rapid intermittent beep (call sign)	Continuous beep sound

■ Change Touch Sensor Input Settings

Change the operation of the touch sensor when it is touched as shown in the following table.

Switch Position	OFF	ON
Input Setting	Momentary operation	Toggle operation

■ Change Touch Sensor Input Settings

Change the operation of the touch sensor when it is touched as shown in the following table.

LED Color \ Switch Position	Switch 3	Switch 4
OFF	OFF	OFF
Red	ON	OFF
Blue	OFF	ON
White	ON	ON

- E.g. 1) If momentary operation and a red color LED have been set, touching the touch sensor will light up in red, regardless of the color that the LED is being controlled with the signal wire (or if it is off).
- E.g. 2) If toggle operation and LED off have been set, touching the touch sensor once will turn the LED off, regardless of the color that the LED is being controlled with the signal wire. The LED will remain off until touching the light again, even if the condition of the signal wire has been changed.

Notice

- Always move your hand away from the touch sensor after changing the DIP Switch.

■ About the Touch Sensor

To turn the touch sensor to ON, touch the following symbol on the top of the globe with the middle of your finger or palm of your hand. The response time of the touch sensor is 100 ms.

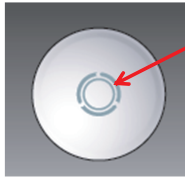

Touch here

⚠ Caution

- Do not hit or press the touch sensor with excess force. Doing so may result in damage to the product.

Notice

- The touch sensor may not respond if you touch the sensor too slowly.
- Touching continuously for 60 seconds is considered an incorrect operation, and the condition when touched is forcibly canceled. The light will respond by releasing your hand from the globe and touching it again.

TYPE NE-IL

Using the NE-IL

This product is an IO-Link compliant product.
Follow the instructions for wiring up " 5 Wiring "(P. 17).

The IO-Link master can control the LED and the buzzer.
The functions that can be used differs depending on the product.
Available functions are shown in the following table.

Function	NE-ILNN	NE-ILNB	NE-ILTN	NE-ILTB	NE-ILXB
Touch Sensor Input	—	—	○	○	○
Analog Input	—	—	—	—	○
Digital Input	—	—	—	—	○

Changing the "Operating Mode" settings enables operation in the following modes:

- Color Specification Mode
- Level Mode
- Analog Input Mode (NE-ILXB only)
- Digital Input Mode (NE-ILXB only)

The parameters used in each mode are shown in the following table.
Refer to "Common Items for Each Mode" (P. 25) for common items.

Parameter \ Mode	Color Specification	Level	Analog Input	Digital Input
2000: LED Intensity	○	○	○	○
2001: Buzzer Sound Level	○	○	○	○
2002: SIO LED Color	○	○	○	○
2003: SIO LED Pattern	○	○	○	○
2004: Touch Sensor LED Color	○	○	—	—
2005: Touch Sensor LED Pattern	○	○	—	—
2006: Touch Sensor Buzzer Pattern	○	○	—	—
2007: Digital Input LED Color	—	—	—	○
2008: Digital Input LED Pattern	—	—	—	○
2009: Digital Input Buzzer Pattern	—	—	—	○
2010: Analog Input Threshold	—	○	○	—
2011: Analog Input LED Color	—	○	○	—
2012: Analog Input LED Pattern	—	○	○	—
2013: Analog Input Buzzer Pattern	—	○	○	—

■ Parameter Settings

For information about the parameter settings, please download the IODD from the LR6-IL page on our homepage (www.patlite.com/).

Please also download and use the parameter sheet in the same way.

■ Common Items

The common processed data shown in the following table can be received by the master can be received in each mode.

	bit7	bit6	bit5	bit4	bit3	bit2	bit1	bit0
Byte 0	Analog Input Value (Lower 8 bits of total 11 bits) *							
Byte 1	Touch Sensor Input ON / OFF	Digital Input ON / OFF	Not used	Memory Error	Touch Sensor Error	Analog Input Value (Upper 3 bits) *		

* 3.2mA ~ 4 mA (-25 ~ 0) / 4 mA ~ 20 mA (0 ~ 500) / 20 mA ~ 21 mA (500 ~ 531)

■ Color Specification Mode

In this mode, LED and buzzer details are specified for control.

Other settings are specified using the parameters.

Send the processed data by referring to the table below.

	bit7	bit6	bit5	bit4	bit3	bit2	bit1	bit0
Byte 0	LED Pattern				Not used	LED Color		
Byte 1	Buzzer Pattern				Not used			Buzzer ON / OFF

■ Level Mode

In this mode, LED and buzzer details are set using the parameters, and controlled with the values of the processed data.

Send the processed data by referring to the table below.

	bit7	bit6	bit5	bit4	bit3	bit2	bit1	bit0
Byte 0	Analog value (Lower 8 bits of total 9 bits)							
Byte 1	Not used							Analog value (Upper 1 bit)

* Values from 0 (0x000) to 500 (0x1F4) can be entered as analog values.

Refer to “Analog Control Examples” (P. 24) for an example of control using Analog Input Mode.

■ Analog Input Mode

In this mode, LED and buzzer control uses analog input values without using processed data.

Settings are specified using the parameters.

Refer to the following image for values used for analog input.

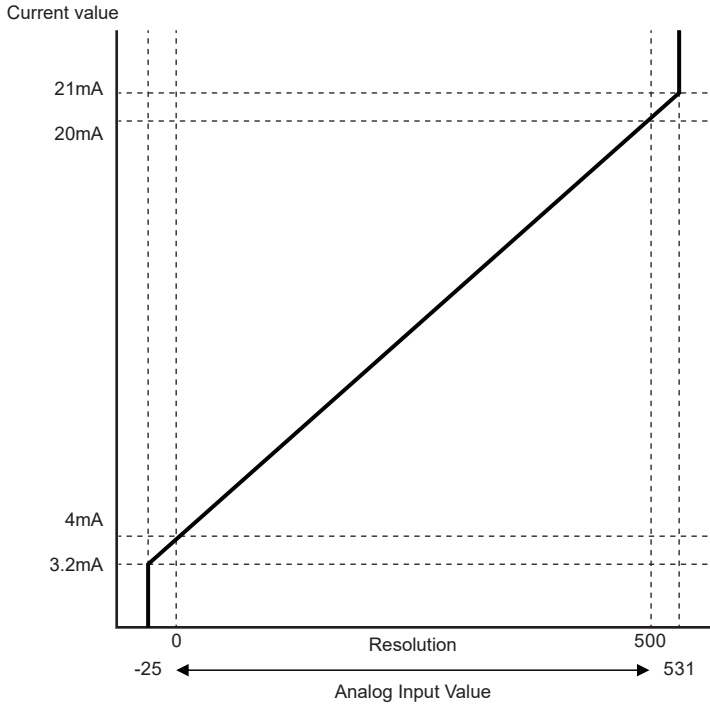

Analog Control Examples)

	byte										
	1	2	3	4	5	6	7	8	9	10	11
index 2010: Analog Input Value Threshold	50	100	150	200	250	300	350	400	450	475	
index 2011 Analog Input LED Color	4	4	4	2	2	2	3	3	3	1	0
index 2012 Analog Input LED Pattern	1	2	0	1	2	0	1	2	0	3	0
index 2013 Analog Input Buzzer Pattern	0	0	0	0	0	0	0	0	0	3	0

For Index2010 enter a value that is larger than the value specified by the lower byte. If 0 is specified, the parameter for that byte will be ignored.

byte11 does not exist for Index2010, but specifying it for Index2011 to 2013 specifies the operation up to set the threshold value for byte1 from default conditions.



Analog Input Value	LED Color	LED Pattern	Buzzer Pattern
49	OFF	Lit	Buzzer 0 (OFF)
50 - 99	Blue	1 sec. Flash (Slow)	Buzzer 0 (OFF)
100 - 149	Blue	500 ms Flash (Medium)	Buzzer 0 (OFF)
150 - 199	Blue	Lit	Buzzer 0 (OFF)
200 - 249	Green	1 sec. Flash (Slow)	Buzzer 0 (OFF)
250 - 299	Green	500 ms Flash (Medium)	Buzzer 0 (OFF)
300 - 349	Green	Lit	Buzzer 0 (OFF)
350 - 399	Yellow	1 sec. Flash (Slow)	Buzzer 0 (OFF)
400 - 449	Yellow	500 ms Flash (Medium)	Buzzer 0 (OFF)
450 - 474	Yellow	Lit	Buzzer 0 (OFF)
475	Red	250 ms Flash (Fast)	Buzzer 3

Due to variations in the analog input value, the value specified for Index2010 is the threshold value, and hysteresis is specified to 20 for the downward direction. Note that if the specified threshold value is 20 or less, the hysteresis is 1.

■ Digital Input Mode

In this mode, LED and buzzer control uses digital input values without using processed data. Settings are specified using the parameters.

■ Common Items for Each Mode

About LED Colors

The “LED Color” used in each mode is shown in the following table.

Color	Setting
OFF	0
Red	1
Green	2
Yellow	3
Blue	4
Purple	5
Cyan	6
White	7

About LED Patterns

The “LED Pattern” used in each mode is shown in the following table.

Pattern		Setting
Name	Interval	
Lit	-	0
1 sec. Flash (Slow)	500 ms	1
500 ms Flash (Medium)	250 ms	2
250 ms Flash (Fast)	125 ms	3
Single Flash	500 ms	4
Double Flash	500 ms	5
Triple Flash	500 ms	6
Sine Curve (slow)	6 s	7
Sine Curve (fast)	3 s	8

About Buzzer Patterns

The "Buzzer Pattern" used in each mode is shown in the following table.

Pattern Name	Setting
Silent	0
Continuous beep sound	1
Rapid intermittent beep (call sign)	2
Rapid hi-low	3
Sweep sound	4
Continuous beep sound 500ms ON / 500ms OFF	5
Rapid intermittent beep (call sign) 500ms ON / 500ms OFF	6
Rapid hi-low 500ms ON / 500ms OFF	7
Sweep sound 500ms ON / 500ms OFF	8

About the Touch Sensor

Refer to "About the Touch Sensor" (P. 20) for the NE-M1A.

7 Troubleshooting

TYPE NE-24A

Troubleshoot problems that occur by following the instructions in the table below.

No.	Problem	Confirmation	Remedy
1	The LED does not light.	Has the wiring been connected properly?	Wire the LED again while referring to the instructions in "5 Wiring" (P. 13).
		Is the power source supplying the proper voltage and current?	Use the appropriate voltage.
		Has the fuse blown?	Replace the fuse if it has blown.

TYPE NE-M1A

Troubleshoot problems that occur by following the instructions in the table below.

No.	Problem	Confirmation	Remedy
1	The LED does not light.	Has the wiring been connected properly?	Wire the LED again while referring to the instructions in " 5 Wiring " (P. 13).
		Is the power source supplying the proper voltage and current?	Use the appropriate voltage.
		Has the fuse blown?	Replace the fuse if it has blown.
		Is touch sensor input being used?	Check " 6 Using the LED and Buzzer" (P. 18). For products with T in the model name, the touch sensor input has priority out of touch sensor input and signal wire input.
2	The color of the LED differs from the desired color.	Has the wiring been connected properly?	Wire the LED again while referring to the instructions in " 5 Wiring " (P. 13).
		Is touch sensor input being used?	Check " 6 Using the LED and Buzzer" (P. 18). For products with T in the model name, the touch sensor input has priority out of touch sensor input and signal wire input.
3	The LED does not flash.	Has the wiring been connected properly?	Wire the LED again while referring to the instructions in " 5 Wiring " (P. 13).
		Check the product model.	Products with T in the model name do not have a flash function.
4	The buzzer does not sound.	Has the wiring been connected properly?	Wire the LED again while referring to the instructions in " 5 Wiring " (P. 13).
		Is the power source supplying the proper voltage and current?	Use the appropriate voltage.
		Has the fuse blown?	Replace the fuse if it has blown.
		Check the product model.	Only products with B in the model name have a buzzer function.
5	The touch sensor does not respond	Has the wiring been connected properly?	Wire the LED again while referring to the instructions in " 5 Wiring " (P. 13).
		Is the power source supplying the proper voltage and current?	Use the appropriate voltage.
		Has the fuse blown?	Replace the fuse if it has blown.
		Are you touching the sensor too slowly?	The touch sensor may not respond if you touch the sensor too slowly.
		Check the product model.	Only products with T in the model name have a touch sensor function.

TYPE NE-IL

Troubleshoot problems that occur by following the instructions in the table below.

No.	Problem	Confirmation	Remedy
1	The LED does not light.	Is the processing data correct?	Refer to the instructions in “ 6 Using the LED and Buzzer ” (P. 18), and resend the processing data.
		Is the specified value correct?	Check “ 6 Using the LED and Buzzer” (P. 18) and set the specified value.
		Has the wiring been connected properly?	Wire the LED again while referring to the instructions in “ 5 Wiring ” (P. 13).
		Is the power source supplying the proper voltage and current?	Check whether the connected IO-Link is putting out the proper voltage.
2	The color of the LED differs from the desired color.	Is the processing data correct?	Refer to the instructions in “ 6 Using the LED and Buzzer ” (P. 18), and resend the processing data.
		Is the specified value correct?	Check “ 6 Using the LED and Buzzer” (P. 18) and set the specified value.
3	The buzzer does not sound.	Is the processing data correct?	Refer to the instructions in “ 6 Using the LED and Buzzer ” (P. 18), and resend the processing data.
		Is the specified value correct?	Check “ 6 Using the LED and Buzzer” (P. 18) and set the specified value.
		Has the wiring been connected properly?	Wire the LED again while referring to the instructions in “ 5 Wiring ” (P. 13).
		Is the power source supplying the proper voltage and current?	Check whether the connected IO-Link is putting out the proper voltage.
4	The touch sensor does not respond	Has the wiring been connected properly?	Wire the LED again while referring to the instructions in “ 5 Wiring ” (P. 13).
		Is the power source supplying the proper voltage and current?	Check whether the connected IO-Link is putting out the proper voltage.
		Are you touching the sensor too slowly?	The touch sensor may not respond if you touch the sensor too slowly.
		Is the specified value correct?	Check “ 6 Using the LED and Buzzer” (P. 18) and set the specified value.
		Check the product model.	Only products with T in the model name have a touch sensor function.

8 Specifications

General Specifications (NE-24A)

Product Name		Signal Beacon
Model		NE-24A-□
Rated Voltage		24V DC
Operating Voltage Range		Rated Voltage $\pm 10\%$
Rated Current Consumption	Typ.	22mA
	Max.	26mA
Rated Power Consumption	Typ.	0.6W
	Max.	0.7W
Operating Ambient Temperature		-30 °C to +50 °C
Operating Ambient Humidity		Less than 90%(No condensation)
Storage Ambient Temperature		-40 °C to +75 °C
Storage Ambient Humidity		Less than 90%(No condensation)
Mounting Location		Indoor
Mounting Direction		All Directions
Protection Rating		IP65, NEMA TYPE 4X, 13 ¹
Environmental Conditions		All Directions
Insulation Resistance		More than 5M Ω at 500VDC between live part and non-current carrying metallic part
Withstanding voltage		500VAC applied for 1min between live part and non-current carrying metallic part without breaking insulation
Mass (Tolerance: $\pm 10\%$)		0.06 kg
Outer Dimensions		Refer to " 3 Names and Dimensions"
Conformity Standards		EMC Directive (EN 61000-6-4, EN61000-6-2) RoHS Directive (EN IEC 63000) UL 508, CSA-C22.2 No.14
Remarks		Due to the characteristics of the LED elements, a variation in difference of the color tone and brightness of every product may occur. Conforms to the CE Requirements Conforms to the UKCA Requirements

- The requirements in each law and regulation are only included in the language designated by each law and regulation. Check the instruction manuals published in each language.

*1 If installed on a flat surface using a cable gland.

General Specifications (NE-M1A)

Product Name		Signal Beacon			
Model		NE-M1ANN-M	NE-M1ANB-M	NE-M1ATB-M	NE-M1ACNB-M
Rated Voltage		12V DC to 24V DC			
Operating Voltage Range		10V DC to 30V DC			
Rated Current Consumption	Typ.	12V DC	55mA	80mA	
		24V DC	45mA	65mA	
	Max.	12V DC	65mA	95mA	
		24V DC	50mA	75mA	
Rated Power Consumption	Typ.	12V DC	0.7W	1.0W	
		24V DC	1.1W	1.6W	
	Max.	12V DC	0.8W	1.2W	
		24V DC	1.2W	1.8W	
Standby Current		Less than 20mA			
Inrush Current		Less than 0.4A / 2msec			
Operating Ambient Temperature		-25 °C to +60 °C			
Operating Ambient Humidity		Less than 90 % (No condensation)			
Storage Ambient Temperature		-40 °C to +75 °C			
Storage Ambient Humidity		Less than 90 % (No condensation)			
Mounting Location		Indoor			
Mounting Direction		All Directions			
Protection Rating		IP67 NEMA TYPE 4X,13	IP65 NEMA TYPE 4X,13		
Environmental Conditions		Upright			
Insulation Resistance		More than 5MΩ at 500VDC between live part and non-current carrying metallic part			
Withstanding Voltage		500VAC applied for 1min between live part and non-current carrying metallic part without breaking insulation			
Sound Pressure Level		-	Typ. 88dB		
Environmental Conditions		Front direction form the center/at 1m. Buzzer sound 「Continuous tone」			
Buzzer Sound		Setting DIP Switch			
		OFF	Intermittent tone	ON	Continuous tone
Luminous Color		Red / Green / Blue / Amber / Cyan / Purple / White			
Touch Sensor input method		-		Electrostatic Capacitance	-
Mass (Tolerance: ±10 %)		0.15 kg	0.17 kg		0.1 kg
Outer Dimensions		Refer to " 3 Names and Dimensions"			
Conformity Standards	UL, cUL	UL 508, CSA-C22.2 No.14			
	FCC	FCC Part 15 SubpartB Class A			
	IC	ICES-003 Class A			
	EMC Directive	EN 61000-6-4, EN 61000-6-2, EN IEC 63000			
	KC	KS C 9610-6-4, KS C 9610-6-2			
Remarks		Due to the characteristics of the LED elements, a variation in difference of the color tone and brightness of every product may occur. UL Recognized Component(File No.E215660) Conforms to the CE Requirements Conforms to the UKCA Requirem			

General Specifications (NE-IL)

Product Name		IO-Link Signal Beacon				
Model		NE-ILNN-M	NE-ILTN-M	NE-ILNB-M	NE-ILTB-M	NE-ILXB-M
Rated Voltage		24V DC				
Operating Voltage Range		18V - 30V DC				
Rated Current Consumption	Typ.	40mA		80mA		
	Max.	50mA		100mA		
Rated Power Consumption	Typ.	1.0W		2.0W		
	Max.	1.2W		2.4W		
Inrush Current		Less than 10A / 0.2msec				
Operating Ambient Temperature		-25 °C to +60 °C				
Operating Ambient Humidity		Less than 90%(No condensation)				
Storage Ambient Temperature		-40 °C to +75 °C				
Storage Ambient Humidity		Less than 90%(No condensation)				
Mounting Location		Indoor				
Mounting Direction		Upright				
Protection Rating		IP65, NEMA TYPE 4X,13				
Environmental Conditions		Upright				
Insulation Resistance		More than 5MΩ at 500VDC between live part and non-current carrying metallic part				
Withstanding Voltage		500VAC applied for 1min between live part and non-current carrying metallic part without breaking insulation				
Sound Pressure Level		-		Typ. 88dB		
Environmental Conditions		Front direction form the center/at 1m. Buzzer sound 「Continuous tone」				
Buzzer Sound (NE-IL <input type="checkbox"/> B-M)	1	Continuous tone		5	Continuous tone 500ms ON / 500ms OFF	
	2	Intermittent tone		6	Intermittent tone 500ms ON / 500ms OFF	
	3	High-Low tone		7	High-Low tone 500ms ON / 500ms OFF	
	4	Sweep sound		8	Sweep sound 500ms ON / 500ms OFF	
Lumious Color		Red / Green / Blue / Amber / Cyan / Purple / White				
Touch Sensor input method		-	Electrostatic Capacitance	-	Electrostatic Capacitance	
Analog Input Range		-				4mA to 20mA
Digital Input		-				Voltage contact (NPN/PNP Transistor)
Mass (Tolerance: ±10 %)		0.09kg		0.10kg		
Outer Dimensions		Refer to “ 3 Names and Dimensions”				
Compliance Standards		EMC Directive (EN 61000-6-4, EN61000-6-2) RoHS Directive (EN IEC 63000) UL 508, CSA-C22.2 No.14 FCC Part 15 SubpartB Class A ICES-003 KC(KN 61000-6-4, KN61000-6-2)				
Remarks		Due to the characteristics of the LED elements, a variation in difference of the color tone and brightness of every product may occur. Conforms to the CE Requirements Conforms to the UKCA Requirement				

9 Service Parts

These are the various parts for the customer to use when repairing or replacing parts for the product.

O-Ring



Number: 1

10 Optional Parts

The optional parts for this product are listed below. (Top line: Part Name; Bottom: Model)

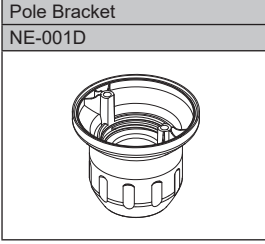

Model Number Configuration

	Model			Body Color
Model Number	NE	–	001	D

D : Off-darkgray

External Diagram

(Unit: mm)

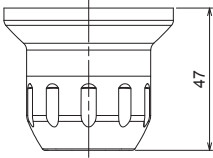

Applicable pole

POLE	–	800A21
POLE	–	300A21
POLE	–	100A21

Applicable bracket

SZ	–	010
SZ	–	016A

General Specifications

Product Name	Pole Bracket
Model	NE-001D
Installation location	Indoor
Installation direction	Upright direction
Mass (Tolerance: ±10 %)	0.031 kg (With one sealing rubber attached)

Installation

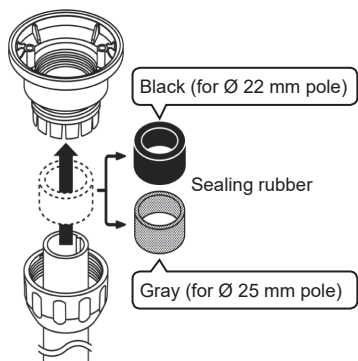

TYPE NE-IL NE-M1ACNB

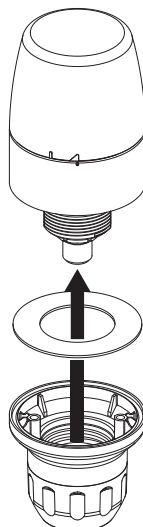

- Remove the M30 nut on the main unit.

TYPE NE-24A NE-M1A

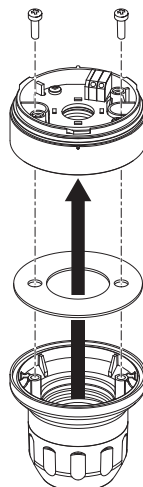

- Recommended installation screw: 4 × 12 mm
Self tapping screw for plastics
- Recommended torque: 1 N m

⚠ Caution

- After mounting the pole, check that the pole does not come loose.
- Use in an area with no vibrations.

Wall Mounting Bracket

NE-002D

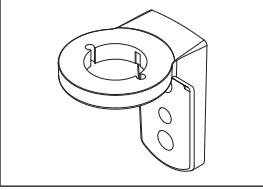

Model Number Configuration

	Model		Body Color
Model Number	NE	– 002	D

D : Off-darkgray

External Diagram

(Unit: mm)

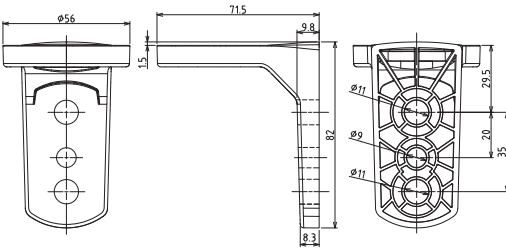

General Specifications

Product Name	Wall Mounting Bracket
Model	NE-002D
Installation location	Indoor
Installation direction	Upright direction
Mass (Tolerance: ±10 %)	0.034 kg

Installation

TYPE NE-IL
NE-M1ACNB

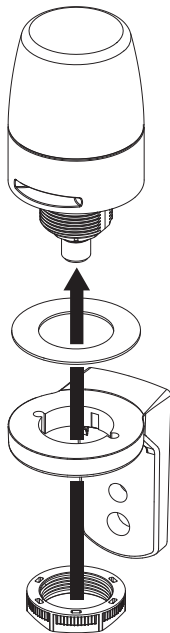

TYPE NE-24A
NE-M1A

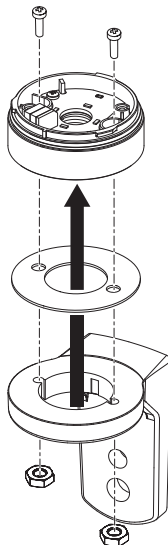

- Recommended installation screw:
M4 × 20 mm Pan head screw
- M4 Hexagon nut
- Recommended torque: 0.6 N m

⚠ Caution

- Use in an area with no vibrations.

Parts for International Models

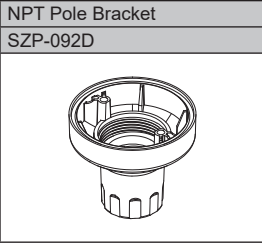

External Diagram

(Unit: mm)

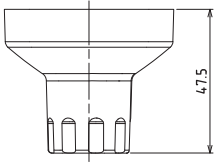

Model v Configuration

	Model		Body Color
Model Number	SZP	–	092
			D

D : Off-darkgray

General Specifications

Product Name	NPT Pole Bracket
Model	SZP-092D
Installation location	Indoor
Installation direction	Upright direction
Mass (Tolerance: $\pm 10\%$)	0.023 kg

Installation

■ Mounting the NPT pole

Press down on A when mounting to the pole.
Forcibly mounting it may cause damage.
(Tightening torque: 2.25 N·m)

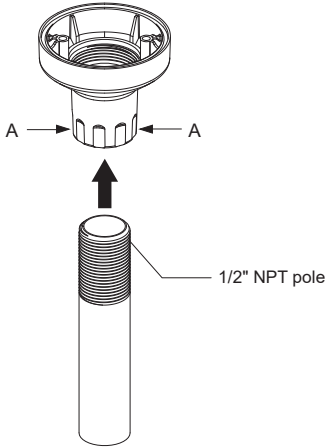

TYPE NE-IL NE-M1ACNB

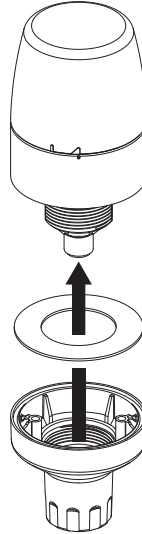

- Remove the M30 nut on the main unit.

TYPE NE-24A NE-M1A

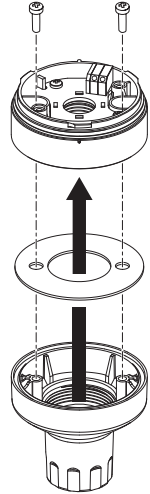



- Recommended installation screw: 4 × 12 mm Self tapping Screw for plastics
- Recommended torque: 1 N m

⚠ Caution

- After mounting the pole, check that the pole does not come loose.
- Use in an area with no vibrations.

The following optional parts can also be used with the NE-24A and NE-M1A. (Except NE-M1ACNB)

Round Multi-pitch Bracket	Round Bracket	Wall Mounting Bracket
SZP-001W	SZP-003W	SZK-001U
		
Aluminum Pole N Type	Aluminum Pole T Type	
POLE22-[0100/0300/0500/0800/1000]AN	POLE22-[0100/0300/0500/0800/1000]AT	
