

- » Sleek design with NEW 18 mm width in accordance with DIN norm
- » Conforms to IEC 61812-1
- » Wide power supply range (12-240 V AC/DC)
- » 1 SPDT relay output (10A)
- » Wide and easily adjustable time range
- » LED notifications
- » High sensitivity and switching capacity
- » High mechanical endurance
- » Multifunctional
- » Function control with trigger input

Type	Order No	Mode	Time Range
Z1T-M2	261015	ND, FD	0.1 sec.. 99.9 hours
Z1K-M2A	261016	yND, yFD	0.1 sec.. 99.9 hours
Z1T-M4	261017	ND, FD, NDF, FDF	1 sec.. 10 days
Z1T-M5	261018	ND, FD, NFD, NDF, FDF	0.1 sec.. 10 days

Operating Voltage	12..240V AC/DC ±10%
Operating Frequency	45..65Hz
Power Consumption	DC < 1.5 W
	AC < 5 VA
Relay Outputs	Number and Type of Contacts 1 C/O
	Maximum Switching (Voltage/Current/Power) 250VAC / 10A / 1250 VA
Cable Cross Section	2.5mm² / 14 AWG
Screw Tightening Torque	0.5 Nm
Cable Stripping Size (Min / Max)	8mm / 9mm
Operating Temperature Range	-20 / +60 °C
Protection Degree (IEC 60529)	IP 20

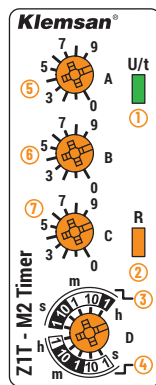
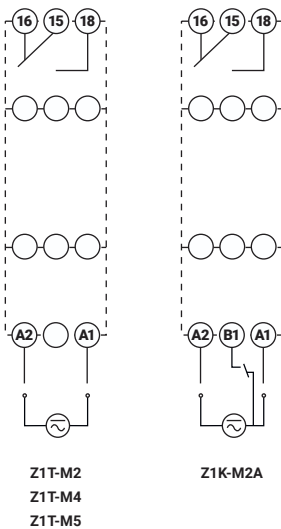
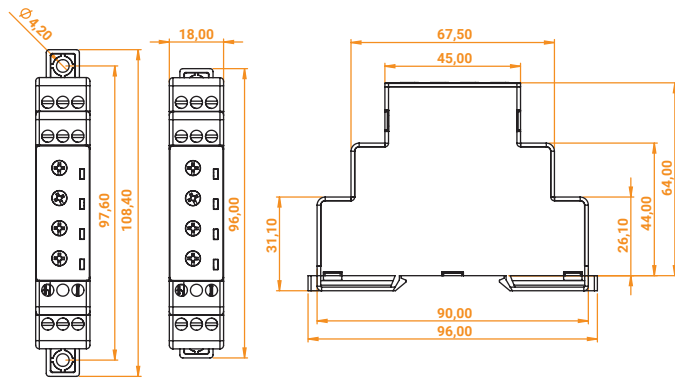

- Power Status LED
 - Relay Status LED
 - "ton" Delay Time Range
 - "toff" Delay Time Range
 - Delay Multiplier Adjustment Pot (x10)
 - Delay Multiplier Adjustment Pot (x0.1)
 - Delay Multiplier Adjustment Pot (x0.1)
- t: (Ax10+Bx1+Cx0.1)xD

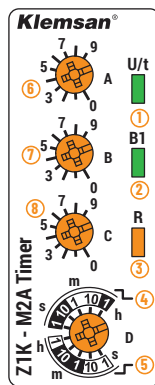

- Power Status LED
 - Relay Status LED
 - Relay Status LED
 - "ton" Delay Time Range
 - "toff" Delay Time Range
 - Delay Multiplier Adjustment Pot (x10)
 - Delay Multiplier Adjustment Pot (x1)
 - Delay Multiplier Adjustment Pot (x0.1)
- t: (Ax10+Bx1+Cx0.1)xD

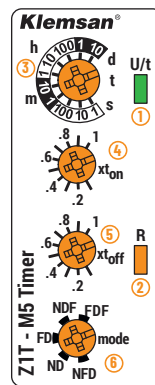

- Power Status LED
- Relay Status LED
- Time Range Adjustment Pot
- "ton" Delay Multiplier Adjustment Pot
- "toff" Delay Multiplier Adjustment Pot
- Mod Selection Pot

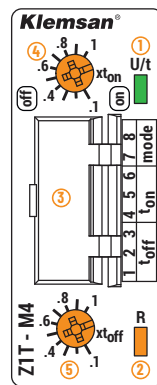

- Power Status LED
- Relay Status LED
- Time Range Adjustment and Mod Selection Switches
- "ton" Delay Multiplier Adjustment Pot
- "toff" Delay Multiplier Adjustment Pot

OFF (0)	ON (1)	t _{off}	t _{on}	mode	t _{on} (4,5,6), t _{off} (1,2,3)	mode (7,8)
000	000	000	000	000	:10 second	00 : on delay
001	001	001	001	001	:30 second	01 : off delay
010	010	010	010	010	:100 second	10 : on flasher
011	011	011	011	011	:10 minute	11 : off flasher
100	100	100	100	100	:60 minute	
101	101	101	101	101	:10 hour	
110	110	110	110	110	:100 hour	
111	111	111	111	111	:10 day	

OPERATION MODE	FUNCTION ILLUSTRATION	FUNCTION STATEMENT
On Delay (mod: ND)		The output relay is initially de-energized and energized after an adjustable time delay, t _{off} .
Off Delay (mod: FD)		The output relay is initially energized and de-energized after an adjustable time delay, t _{on} .
ON-OFF Delay (mod: NFD)		The output relay is initially de-energized and energized after an adjustable time delay, t _{off} , and stays energized for an adjustable period, t _{on} , and then de-energized.
On Delay with Trigger (mod: yND)		The output relay is initially de-energized and energized after an adjustable time delay, t _{off} . The function can be restarted without power off with the trigger signal.
Off Delay with Trigger (mod: yFD)		The output relay is initially energized and de-energized after an adjustable time delay, t _{on} . The function can be restarted without power off with the trigger signal.
OFF Flash (mod: FDF)		The output relay is initially de-energized and energized after an adjustable time delay, t _{off} , and stays energized for an adjustable period, t _{on} , and then de-energized. This loop is repeated until the device is powered off.
ON Flash (mod: NDF)		The output relay is initially energized and de-energized after an adjustable time delay, t _{on} , and stays de-energized for an adjustable period, t _{off} , and then energized. This loop is repeated until the device is powered off.