



MEASTRO



Klemsan[®]

TABLE OF CONTENTS

SECTION 1	GENERAL FEATURES.....	51
1.1	General Features.....	52
1.2	Technical Specifications.....	53
1.3	Proper Use and Safety Conditions.....	53
1.4	General View, Connections & Definitions(mm).....	54
SECTION 2	CONTROL.....	55
2.1	Manual Test Mode.....	56
SECTION 3	MENUS AND SETTINGS.....	57
3.1	Settings Menus.....	58
3.1.1	Communication Settings.....	58
3.1.2	Date and Time Settings.....	58
3.1.3	Daylight Saving Time Settings.....	59
3.1.4	Holiday Settings.....	61
3.1.5	Device Settings.....	62
3.1.6	Location (Coordinate and Region) Settings.....	63
3.1.7	Prayer Settings.....	64
3.2	Add or Modify Programs.....	65
3.2.1	Deleting Programs.....	65
3.3	Monitoring.....	66
3.4	Login.....	67
SECTION 4	IR CONTROLLER AND USER INTERFACE PROGRAM.....	69
4.1	Usage Mods.....	69
4.1.1	Transferring data to MEASTRO-R from the relay.....	70
SECTION 5	Meastro User Interface Program USER INTERFACE.....	72
5.1	Setup.....	72
5.2	UsingMeastro User Interface Program.....	75
5.2.1	UsingMeastro User Interface Program with Meastro.....	75
5.2.2	UsingMeastro User Interface Program with Meastro-S485.....	84
SECTION 6	MODBUS PROTOCOL.....	9
FIGURES		
1.1	Display Discriptions.....	54
1-2	General view Meastro 121, 221, 321.....	54
1-3	General view Meastro 122, 222, 322.....	54
1-4	Meastro 121,221,321 Connections and wiring.....	54
1-5	Dimensions.....	54
1-6	Meastro 122, 222, 322 Connections and wiring.....	54
4-1	General View & Definitions for IR Controller.....	69
5-1	Setup-1.....	72
5-2	Setup-2.....	72
5-3	Setup-3.....	73
5-4	Setup-4.....	73
5-5	Setup-5.....	74

FIGURES

5-6	Configuration Program Shortcuts.....	74
5-7	Select device.....	75
5-8	Select Meastro from Meastro User Interface Program.....	75
5-9	Connection Types.....	76
5-10	Virtual Serial Port.....	77
5-11	Virtual Serial Port.....	77
5-12	Meastro User Interface Program Program Tab.....	78
5-13	Meastro User Interface Program Program Save Tab	78
5-14	Meastro User Interface Program Program Tab.....	79
5-15	Meastro User Interface Program Location Tab.....	80
5-16	Meastro User Interface Program Pray Tab.....	81
5-17	Meastro User Interface Program Date&Time Tab.....	82
5-18	Meastro User Interface Program About Tab.....	83
5-19	Connection Types Offline Configuration.....	83
5-20	Meastro RS-485 Select	84
5-21	Connection Types.....	84
5-22	Connect with USB.....	85
5-23	Connect over TCP/IP.....	86
5-24	Meastro User Interface Program Date&Time Tab.....	87
5-25	Meastro User Interface Program Program Tab	87
5-26	Meastro User Interface Program Program Save Tab	88
5-27	Meastro User Interface Program Program Tab.....	89
5-28	Meastro User Interface Program Location Tab.....	90
5-29	Meastro User Interface Program Prayer Tab.....	91
5-30	Meastro User Interface Program Device Setting Tab.....	92
5-31	Meastro User Interface Program Log Tab.....	93
5-32	Meastro User Interface Program Device Information Tab.....	94
5-33	Meastro User Interface Program Write Tab	94

TABLES

1.1	Selection Table.....	52
1.2	Technical Specifications.....	53
6.1	Modbus Tablosu.....	96

The graphic features a stylized, interconnected network of circles in dark blue and orange. A large orange circle on the left contains the word 'MEASTRO' in grey. A dark blue circle on the right contains the text 'SECTION 1 GENERAL INFORMATIONS' in orange. The background is white.

MEASTRO







**SECTION 1
GENERAL
INFORMATIONS**

SECTION 1 GENERAL FEATURES

1.1 General Features

Meastro is an astronomic time relay which calculates sunrise and sunset times for the given coordinates or city selections and turns the relay contacts on and off to control connected systems without any need of photocells or external sensors. Meastro can be used as digital time relay as well. 100 different programmes can be saved to device memory, relay operations are made according to these programmes. A 100 year calendar, sunrise and sunset times are recorded to device memory. The internal battery of the device has 7 years of lifetime. If any power outages occur, the device continues to operate the programme but cannot operate relays or transfer data via remote control. The internal battery prevents data loss due to power interruptions.

Table 1-1 Selection Table

 Order Number: 270 720						
Device Model	Meastro 121	Meastro 221	Meastro 321	Meastro 122	Meastro 222	Meastro 322
Order Number	270 702	270 703	270 704	270 705	270 706	270 707
Mounting	Rail mount	Rail mount	Rail mount	Rail mount	Rail mount	Rail mount
Digital Program	✓	✓	✓	✓	✓	✓
Astronomical Program	-	✓	✓	-	✓	✓
Prayer Program	-	-	✓	-	-	✓
Number of Relay	2	2	2	2	2	2
Communication	IR	✓	✓	✓	-	-
	RS-485	-	-	-	✓	✓



The device's default language is English. To set the language in Turkish, press and hold the  button for 4sec, while on the main screen.

1.2 Technical Specifications

Operating voltage	180-265VAC
Supply terminals	A1-A2
Number of contacts	2X (AgSnO2)
Rated current	16A/250VAC
Power Consumption	AC Maks. 11 VA
Accuracy	1 sec/day
Renewal period	0,5sec
Display type	LCD
Display size	1.5"
Number of program	100
Duration of the battery reserve	7 years
Protection class	IP40 (Front Panel), IP20 (Terminals)
Operating temperature	-20 °C..+70 °C
Storage temperature	-30 °C..+80 °C
Ralative humidity	Max. %95
Mounting	Rail
Weight	126,4 gr
DTS set	Automatic
IR distance	550 mm

Tablo 1-2 Technical Specifications

1.3 Proper Use and Safety Conditions

- Installation and connections should be established in accordance with the instructions set out in the manual by authorized persons. Unless the connection is built properly, device should not be operated.
- Before wiring the device up, make sure that energy is cut off
- Use a dry cloth to remove the dust from the device/clean the device. Avoid using alcohol, thinner or a corrosive material.
- Device should be engaged only after all the connections are made.
- Do not open the inside of the device. There are no parts which the users can intervene inside.
- Device should be kept away from humid, wet, vibrant and dusty environments.



The manufacturing company may not be kept responsible for unfavorable incidents that arise out of the failure to follow the above cautions.

1.4 General View, Connections & Definitions(mm)

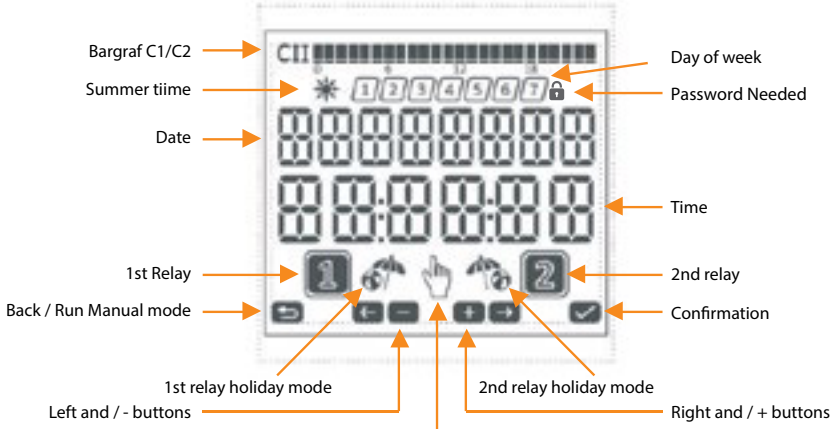

Figure 1-1 Display Descriptions

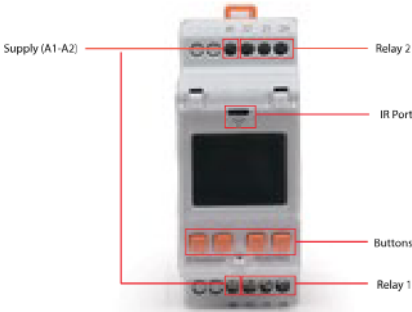

Figure 1-2 General view Meastro 121, 221, 321



Figure 1-3 General view Meastro 122, 222, 322

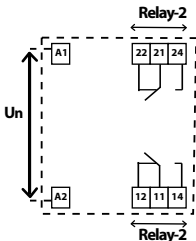

Figure 1-4 Meastro 121,221,321
Connections and wiring

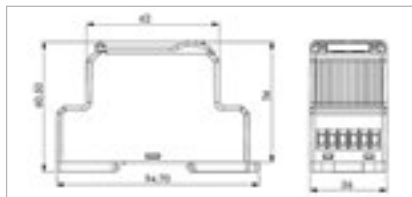

Figure 1-5 Dimensions

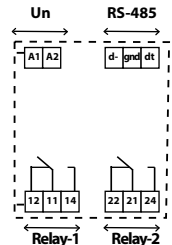

Figure 1-6 Meastro 122, 222, 322
Connections and wiring

The graphic features a central, stylized tree-like structure composed of interconnected circles and lines. The top portion of the structure is orange, while the bottom portion is dark blue. Two large circles are integrated into the design: one on the left, outlined in orange, and one on the right, outlined in dark blue. The text 'MEASTRO' is centered within the orange circle, and 'SECTION 2 CONTROL' is centered within the dark blue circle.

MEASTRO

**SECTION 2
CONTROL**

SECTION 2 CONTROL

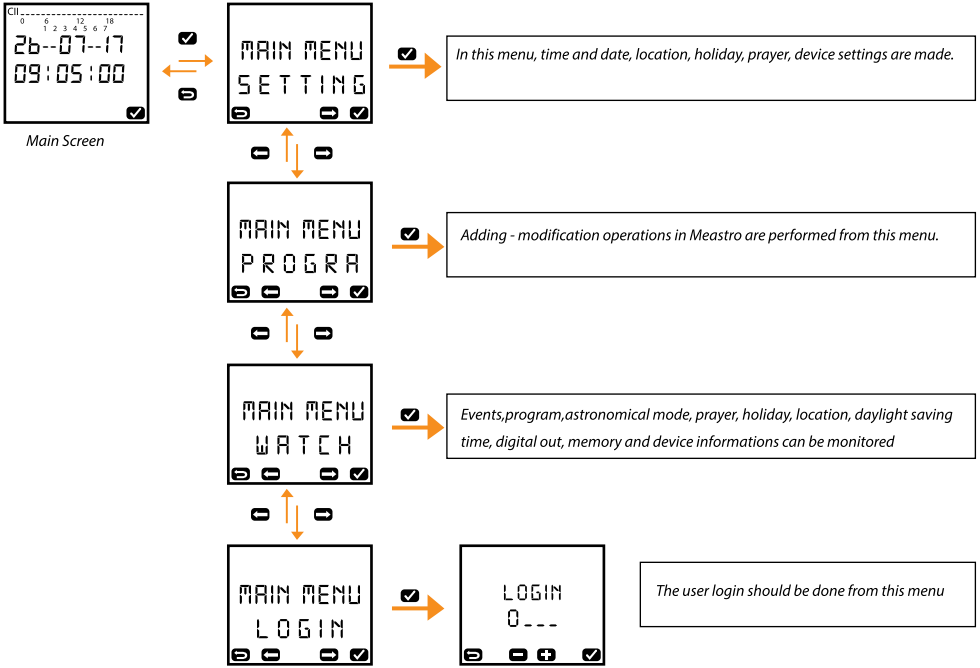

Without login, programs and settings menus are not available for access manually! Default password is 0001.

2.1 Manual Test Mode

Manual test mode using for relay testing. When you press the button for 4 seconds, flashing symbol becomes permanent light and, **1**, **2** icons will appear on the screen. That means C1 and C2 relays are passive condition and directional keys, respectively, C1 and C2 relays can be activated. Pressing the same button again, the relay that you want, became inactive. The active relays are indicated by symbols on the screen **1** and **2**. To exit manual mode, press the button for 4 seconds again.

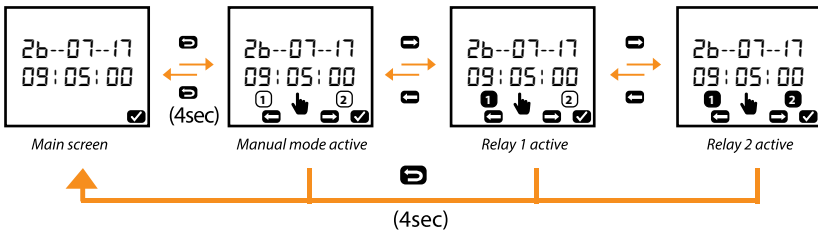

The graphic features a stylized, abstract design composed of interconnected circles and lines in dark blue and orange. A large orange circle on the left contains the word 'MEASTRO' in grey. To the right, a dark blue circle contains the text 'SECTION 3 MENUS AND SETTINGS'. The background is white.

MEASTRO

**SECTION 3
MENUS AND
SETTINGS**

SECTION3 MENUS AND SETTINGS

3.1 Setting Menus

Time and date, location, summer time, holiday mode for each relay, prayer settings and device settings can be made under the settings menu. If the button is pressed on the home screen reveals the settings menu. You can browse settings menu by using , keys. To make the necessary settings, press to enter the the desired menu.



3.1.1 Communication Settings

In this menu, Slave Id and Baud Rate are set.

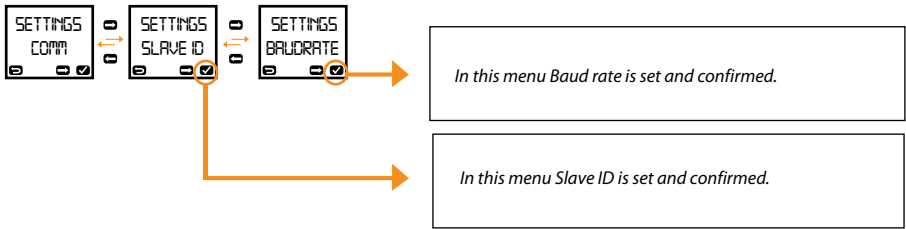

3.1.2 Date and Time Settings

In this menu, Date and time are set.

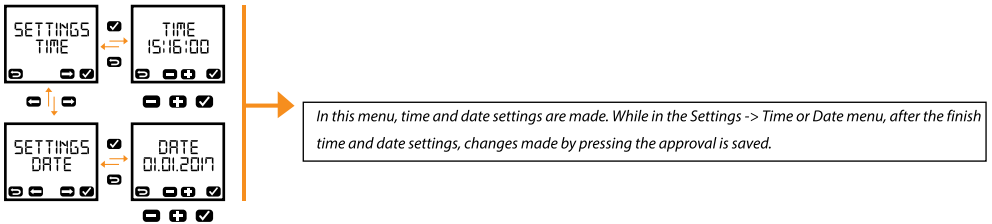

3.1.3 Daylight Saving Time Settings

In this menu, daylight saving time settings are made . There are 4 different parameters, Europe, USA, Custom and OFF.

Europe: For summer time, clocks go forward 1 hour at 3am on the last Sunday in March, and for winter time, back 1 hour at 3am on the last Sunday in October.

USA: Summer time starts on the second Sunday in March. The clocks are moved forward from 2:00 a.m. to 3:00 a.m, and ends on the first Sunday in November, and in fall they are moved back from 2:00 a.m. to 1:00 a.m.

Custom: Daylight saving time start and end dates will be set to specific in this menu.

OFF: This option turns off the daylight saving time.

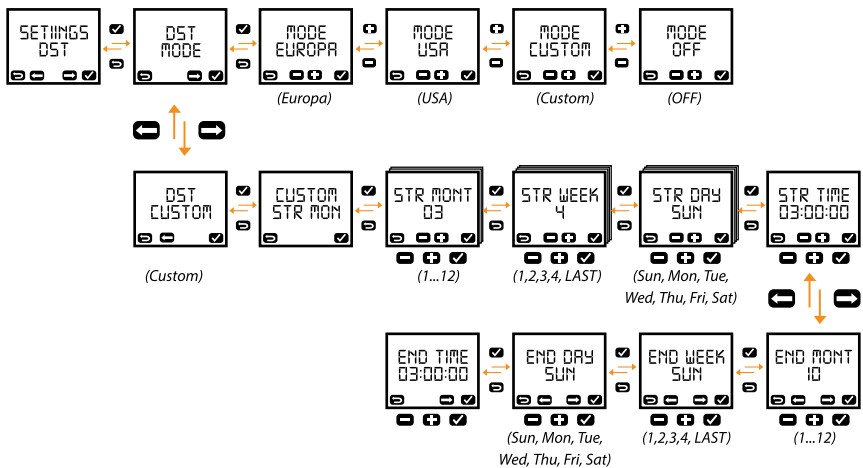

STR MONT: Beginning month of the daylight saving time should be adjusted in this menu.

STR WEEK: Beginning week of the daylight saving time should be adjusted in this menu.

STR DAY: Beginning day of the daylight saving time should be adjusted in this menu.

STR TIME: Beginning time of the daylight saving time should be adjusted in this menu.

END MONT: Ending month of the daylight saving time should be adjusted in this menu.

END WEEK: Ending week of the daylight saving time should be adjusted in this menu.

END DAY: Ending day of the daylight saving time should be adjusted in this menu.

END TIME: Ending time of the daylight saving time should be adjusted in this menu.

Time zone overview:

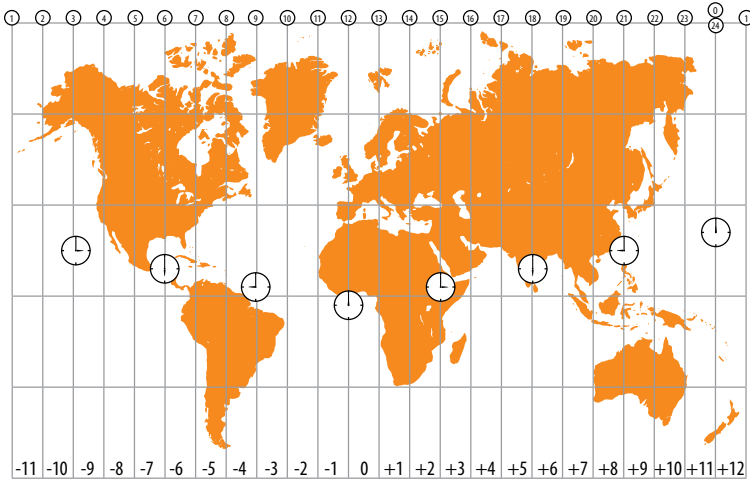

Figure 3-1 Time zones

Some countries and cities according to UTC time:

<p>21:00</p> <p>BRASILIA RIO DE JANEIRO SÃO PAULO</p>	<p>22:00</p> <p>Grønland</p>	<p>23:00</p> <p>ICELAND DAKAR</p>	<p>00:00 DUBLIN LONDRA</p>	<p>01:00</p> <p>OSLO ROME STOCKHOLM WARSAW FRANKFURT PARIS LISBON VIENNA</p>	<p>02:00</p> <p>ANKARA ISTANBUL IZMIR CAIRO ATHENS BEIRUT</p>	<p>03:00</p> <p>MOSCOW TEHERAN BAGHDAD NAIROBI RIYADH MADAGASCAR</p>
<p>18:00</p> <p>CHICAGO DALLAS MEKSIKO GUATEMALA</p>	<p>19:00</p> <p>MONTREAL NEW YORK WASHINGTON CUBA PANAMA</p>	<p>20:00</p> <p>NEW FOUNDLAND CARACAS BUENOS AIRES</p>		<p>04:00</p> <p>BAHRAIN KARACHI</p>	<p>05:00</p> <p>DELHI SRI LANKA BOMBAY</p>	<p>06:00</p> <p>BANGLADESH</p>
<p>15:00</p> <p>AKLAVIK</p>	<p>16:00</p> <p>VANCOUVER SEATTLE SAN FRANCISCO LOS ANGELES</p>	<p>17:00</p> <p>SALT LAKE CITY</p>		<p>07:00</p> <p>BANGKOK</p>	<p>08:00</p> <p>PEKIN HONG KONG PHILIPPINES SINGAPORE JAKARTA</p>	<p>09:00</p> <p>TAIPEI TOKYO SEOUL</p>
<p>12:00</p> <p>NEW ZELAND FIJI ISLANDS</p>	<p>13:00</p> <p>ALASKA</p>	<p>14:00</p> <p>ALASKA HAWAII</p>		<p>10:00</p> <p>SYDNEY MELBOURNE NEW GUINEA</p>	<p>11:00</p> <p>KAMCHATKA</p>	<p>12:00</p> <p>NEW ZELAND FIJI ISLANDS</p>

3.1.4 Holiday Settings

Holiday settings are made under this menu. Holiday programming can be made for both two relays. First, the relay to assign holiday mode is selected, then the action is selected (on or off). If the start position of the relay is selected as on, the relay will be active during the holiday period. If the start position of the relay is selected as off, then the relay will be passive during the holiday. The process is completed by setting start and finish dates for the holiday.

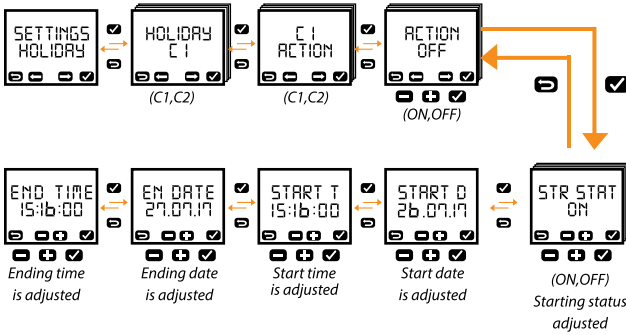

3.1.5 Device Settings

The device settings adjusted by changing the parameters under this menu.

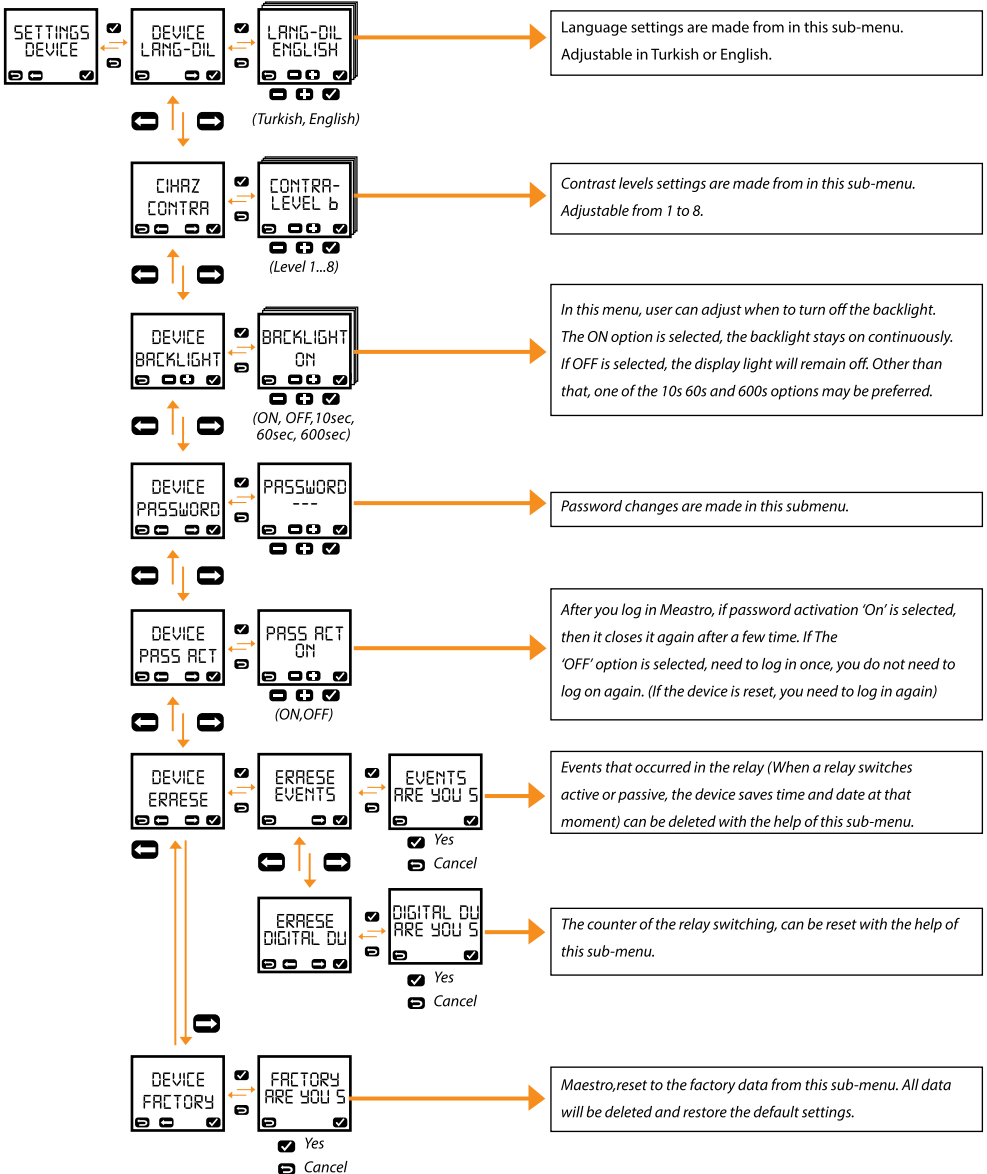

3.1.6 Location (Coordinate and Region) Settings

Coordinates of 81 cities and 161 towns are predefined in device memory. If one of the predefined settings is selected, then sunrise and sunset times are adjusted automatically. If your town is listed in device settings, then you can save your location manually by entering latitude and longitude data.

One of coordinate or region settings should be selected in order to determine sunrise and sunset times for the selections.

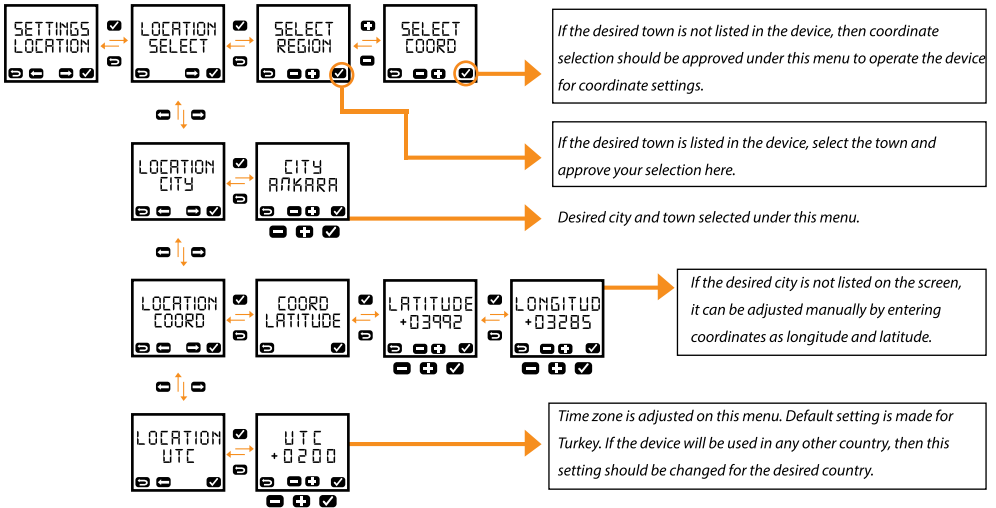

3.1.5 Prayer Settings

Device can be configured as prayer timer by using 7 different methods plus manual setting for more customization.

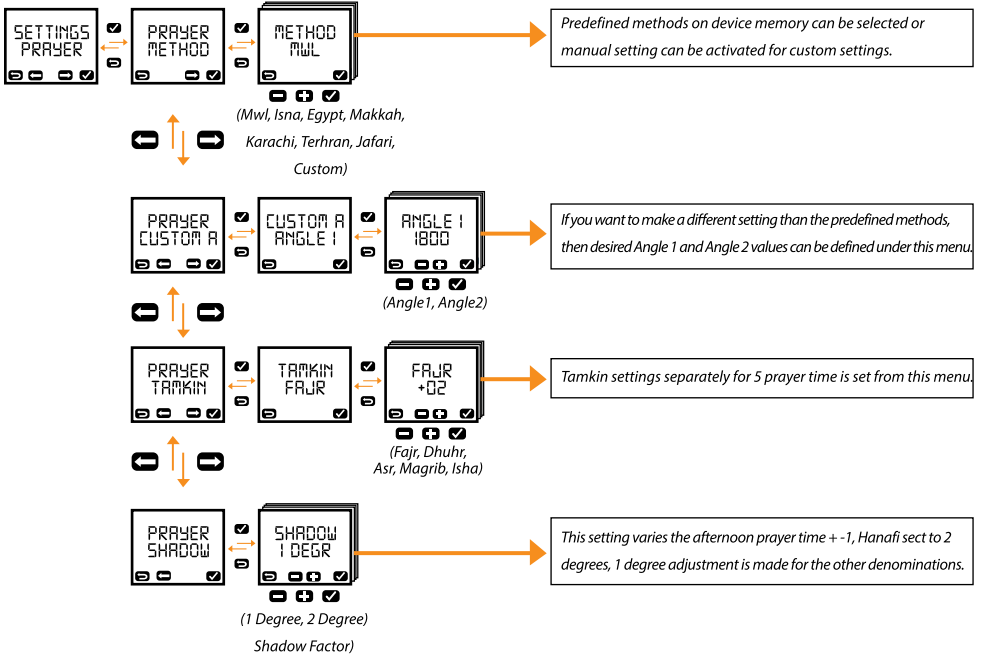

3.2 Add or Modify Programs

Adding - modification operations in Meastro are performed from this menu. The program is scheduled weekly and weekly repeats.

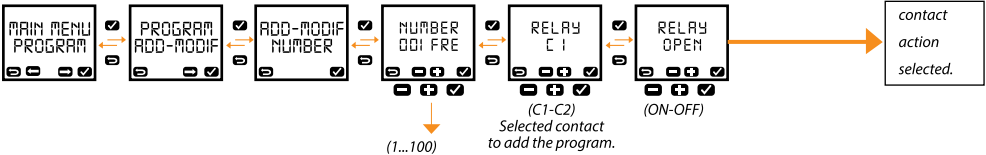

Adding or modify the desired program, is selected sequentially from the sub-menu.

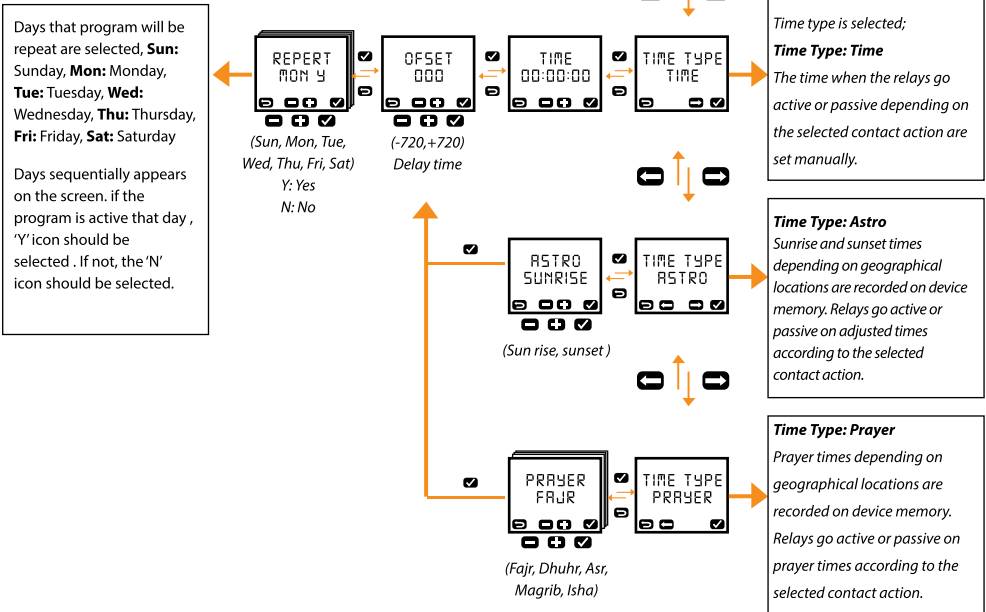

3.2.1 Deleting Programs

Deletion of created entire programs or delete one by one , should be made from this menu. If you want to delete the program, the user confirmation needed. This process is completed with the approval of the User.

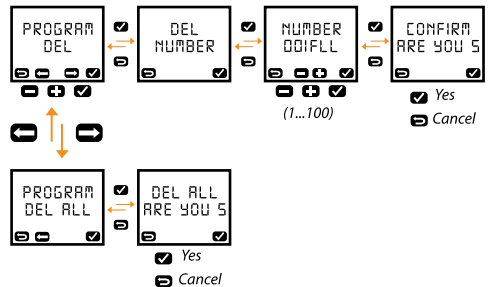

3.3 Monitoring

Logs, programs, operating time and switching counters of the relay can be monitored. Also sunrise-sunset, prayer time, holiday and location settings, memory status and the software version of the device can be monitored from this menu.

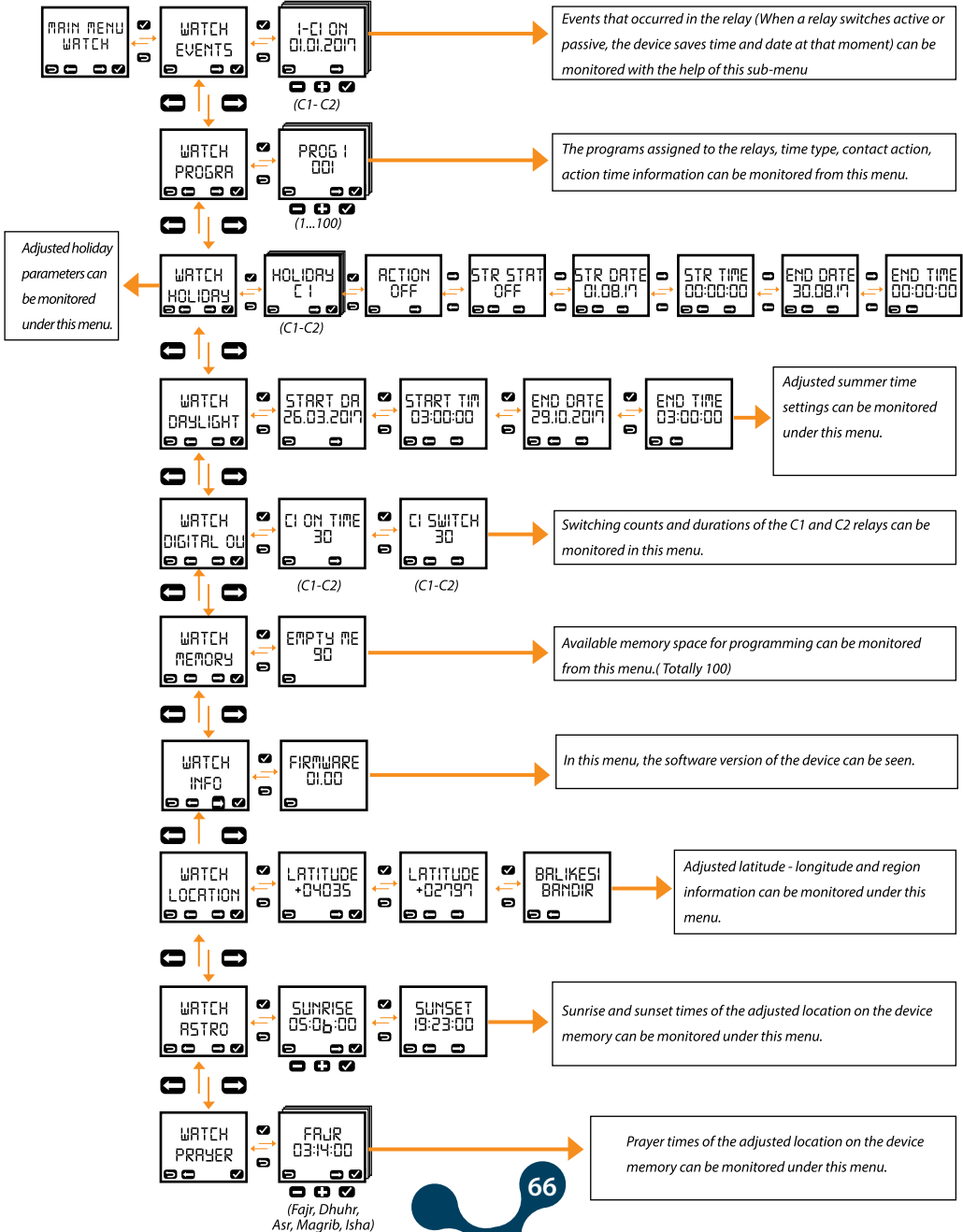

3.4 Login

This menu is used by user to activated the device or to check the status of the device.

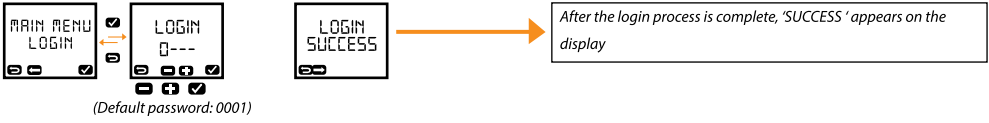

The graphic features a stylized, abstract design composed of interconnected circles and lines in orange and dark blue. On the left, a large orange circle contains the word "MEASTRO" in grey, bold, uppercase letters. To the right, a dark blue circle contains the text "SECTION 4 MEASTRO-RS 485 (IR CONTROLLER)" in orange, bold, uppercase letters. The background is white.

MEASTRO

**SECTION 4
MEASTRO-RS 485
(IR CONTROLLER)**

SECTION 4 MEASTRO-RS 485 (IR CONTROLLER)

MEASTRO-R is a multifunction controller designed for MEASTRO astronomical time relay. The program created by the user interface by installing the infrared data transmission control program, time, location and prayers data separately transferred to the device. Also it can separately transfer program,time,location and prayer datas to controller from relay.

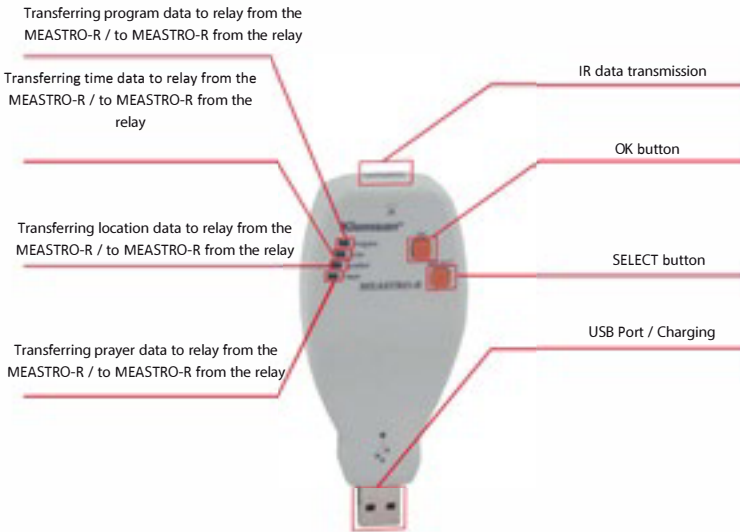

Figure 4-1 General view&Definitions for IR Controller

4.1 Usage Mods: USB port:

MEASTRO-R is sent with the USB extension cable.usb is used to charge IR controller or transfer the program that prepared with user interface to the controller.

Transferring data to relay from the MEASTRO-R:

To turn on the controller to use, It should have been made sure that the controller fully charged. Then, simply press the 'OK' and the 'SELECT' keys briefly at the same time. When remote controller activated, program led lights at first. For example, in order to transfer the data to the it should be ensured that infrared eyes of the controller and the device is supposed to be on the same axis while the program light is fixed. When pressed the 'OK' button, first COM-STR is shown and then if transmission is successful, COM-OK , if not COM-ERR is shown. When process failed, it should be ensured that the infrared eyes of the controller and the device is supposed to be on the same axis. Distance should be maximum 50cm.

The other datas(time,location,prayer) can be transferred using the 'SELECT' button. But first you should be ensured that the led fixed. After that, data transmission that you want is performed with 'OK' button.

4.1.1 Transferring data to MEASTRO-R from the relay:

While the program light is fixed, when the selection button is pressed 4 times, 1 cycle is completed and the program light starts blinking. That mode is transferring data from relay to the MEASTRO-R.

Using the Select button, while the led of the data that you want to transfer is flashing, when pressed the OK button, first COMM-STR is shown and then if transmission is successful, COMM-OK; if not COMM-ERR is shown. When process failed, it should be ensured that the infrared eyes of the controller and the device is supposed to be on the same axis. Distance should be maximum 50cm.



If COMM-STR does not appear at all on the screen, the 4 leds blink 3 times simultaneously on the device. Please check controller position and distance. The maximum effective distance between device with IR controller is 50cm..



While IR controller's leds are fixed, when pressing the 'OK' button, refers to the data transfer from controller to the device. While IR controller's lights blinking, when pressing the 'OK' button, refers to the data transfer from device to the controller.

Screenshots:



Data transfer started



Data transfer is successful



Data transfer is failed

* There is no off button of the MEASTRO-R. If not used turns itself off in 10 seconds.



When the relay's power is cut off, it can not be any transactions between the device and the controller. In addition,if the relay is active, it becomes passive. However, the icons continue to appear on the screen according to the program flow.

The graphic features a large orange circle on the left containing the word "MEASTRO" in grey. To its right is a complex, organic shape composed of interconnected orange and dark blue circles and lines, resembling a molecular or network structure. This shape extends downwards and to the right, where it connects to a dark blue circle containing the text "SECTION 5 MEASTRO USER INTERFACE PROGRAM".

MEASTRO

**SECTION 5
MEASTRO
USER
INTERFACE
PROGRAM**

SECTION 5 MEASTRO USER INTERFACE PROGRAM

5.1 Setup

To start the installation, double-click the Meastro user interface program setup file. The following screen appears when you run the installation file. Please click "Next" button.

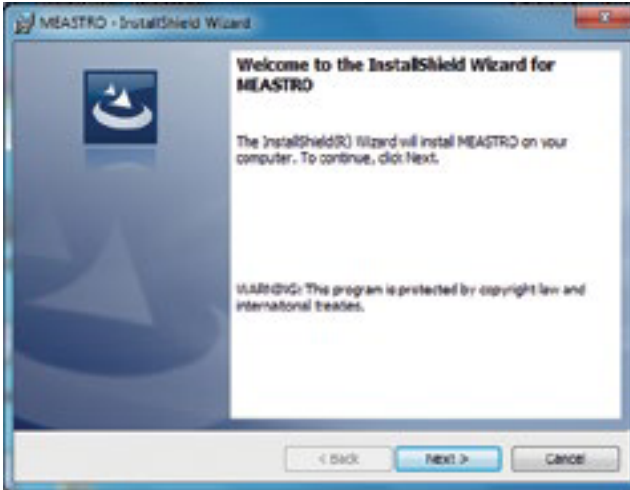

Figure 5-1 Setup-1

- Then the user will see installation folder and the user setting selection screen. After completing your settings, please click 'Next' button.

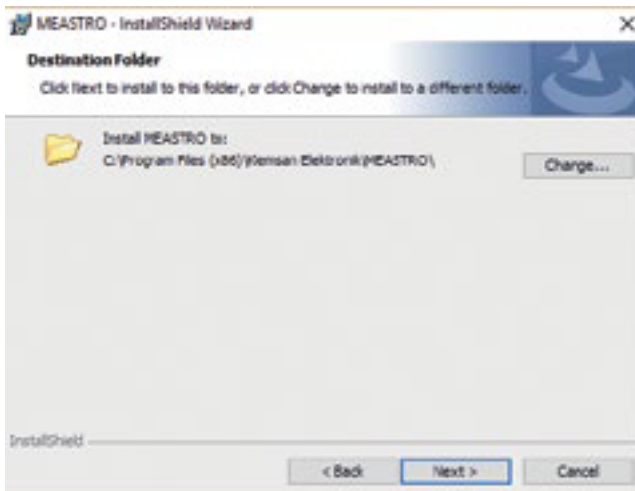

Figure 5-2 Setup-2

- According to the preferences made, the screen to review your settings appears before you upload. If all settings are correct, please click 'Install' to start the installation.

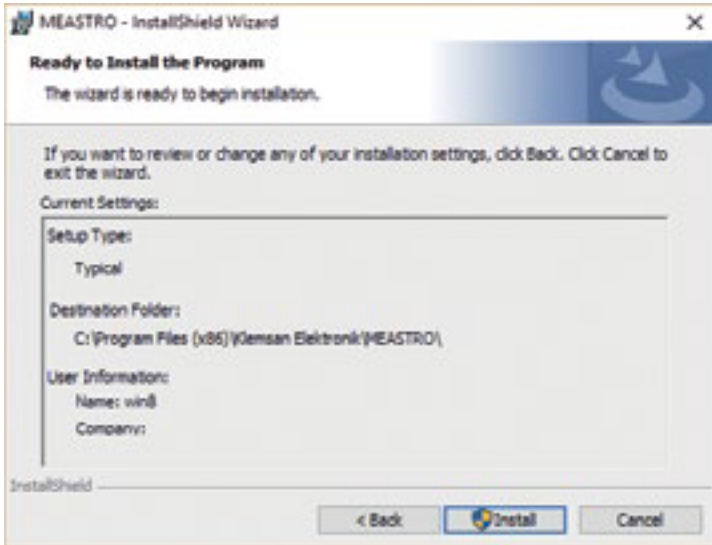

Figure 5-3 Setup-3

- Your operating system will ask your permission for the installation of the software. Please click "Yes" to install the software..

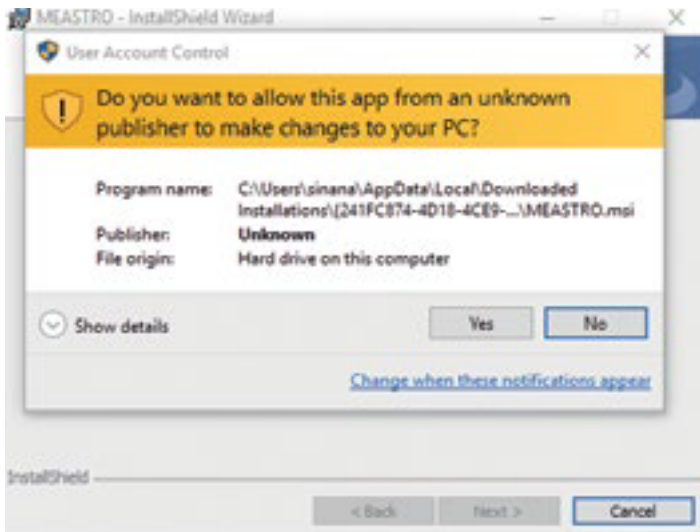

Figure 5-4 Setup-4

- Please click the “Finish” button to complete the setup and close the setup screen.

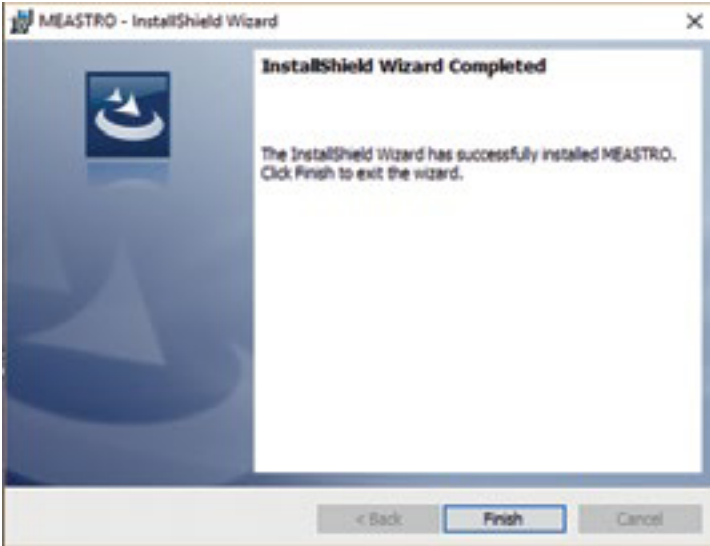

Figure 5-5 Setup-5

User can run the program with the Meastro shortcut on the desktop.

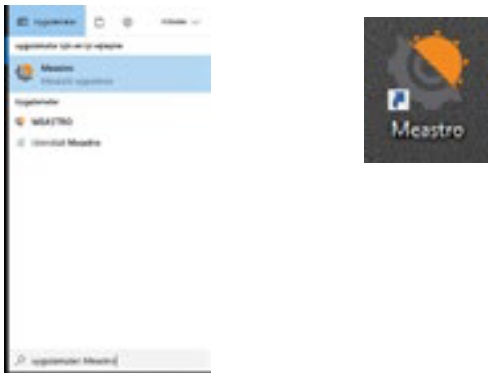

Figure 5-6 Configuration Program Shortcuts

5.2 Using Maestro User Interface

User can configure date time, program, location, prayer and device settings by connecting to the maestro device via USB or TCP / IP.

Maestro User Interface Program First Page

After clicking Maestro shortcut on your desktop, the following screen appears.

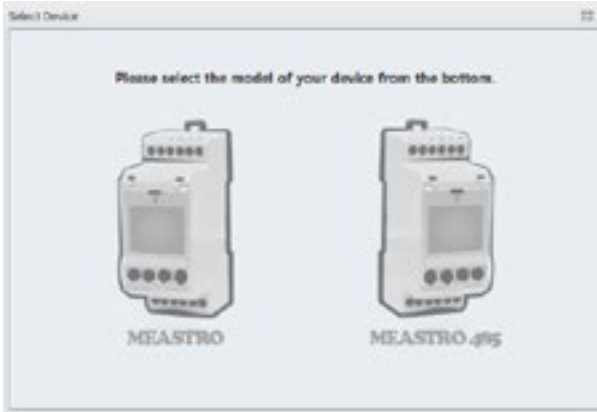

Figure 5-7 Select device

5.2.1 Using Maestro User Interface with Maestro Device

With interface program; the date, time, program, location, prayer settings can be configured. User can write the created programs to Infrared Remote Control (Maestro-R) and then user can install it to Maestro.



Figure 5-8 Select Maestro from Maestro User Interface Program

To access the user interface program, connect the Maestro-R to your computer with a USB cable. It is recommended to connect the device with the connecting cable.



Figure 5-9 Connection Types

Click 'Connect with USB' button to connect Meastro-R device.

When user clicks 'Connect with USB' button, device settings are read and written in series via USB.



Figure 5-10 Virtual Serial Port

If the correct port does not appear in the list when connected to the PC via the USB cable, click the 'Refresh' button, the list will be updated by clicking on it. After '**COM X**' is selected, click the '**Connect**' button.



Figure 5-11 Virtual Serial Port

After connection to Meastro-R, '**Disconnect**' appearance in the lower right corner will appear as '**Connected via USB!**'

When connected to device; Disconnect, Read, Write, Program, Location, Prayer, Date-Time and About will appear on the screen.

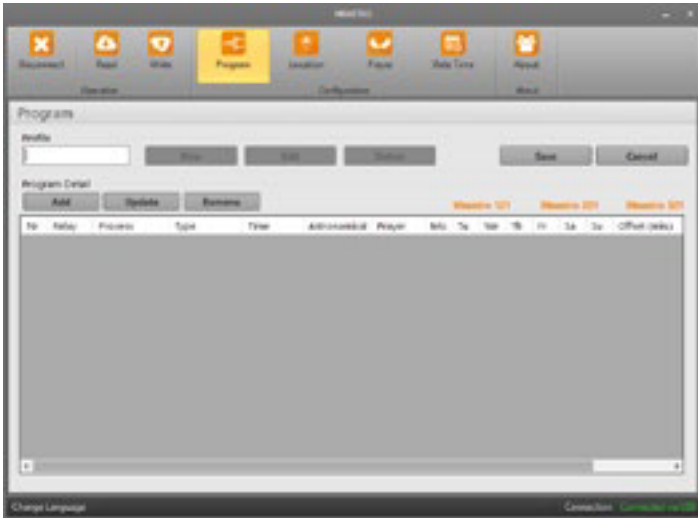

Figure 5-12 Meastro User Interface Program Program Tab

When the connection is made, the interface opens the **'Program'** tab. In this tab, Program Settings are made.

Programs to be saved in the Program tab are created.

It is written to Meastro-R (Infrared Controller) and uploaded to Meastro.

Programs to set can be added, updated or removed via infrared control.

Program settings, desired days of the week Standard, Astro, Prayer time types Relay 1 (C1) - Relay 2 (C2) can be set as active and passive.

Program Settings are set as follows,



Figure 5-13 Meastro User Interface Program Program Save Tab

Click the Add box and the 'Program Detail Page' in the screenshot above appears. Click 'Save Program Detail' button after setting the relevant relays. After registering the program it will look like the following.

Nr: The created program number. It is possible to create up to 100 programs.

Relay: The relay is activated or deactivated when the relay is selected.

Process: Relay which is select before, set activate or deactivate.

Type: It is the part where selected relay is run in time. This part is divided in to 3 parts Standart, Astronomical and Prayer.

- **Standard,** settings are made by the user in hours, minutes and seconds.
- **Astronomical** part runs depending on sunrise and sunset time.
- **Prayer;** device settings are made by selecting the time of Fajr-Dhuhr-Asr-Maghrib-Isha.

Offset (min): The time difference of the set time type. This section applies to Astro and Prayer.

Week Days: The program created for marked days will run.

Description: The definition and notes of the program are written in this section.

Click '**Save Program Detail**' button after setting the relevant relay. After registering the program, the screen will appear as below.

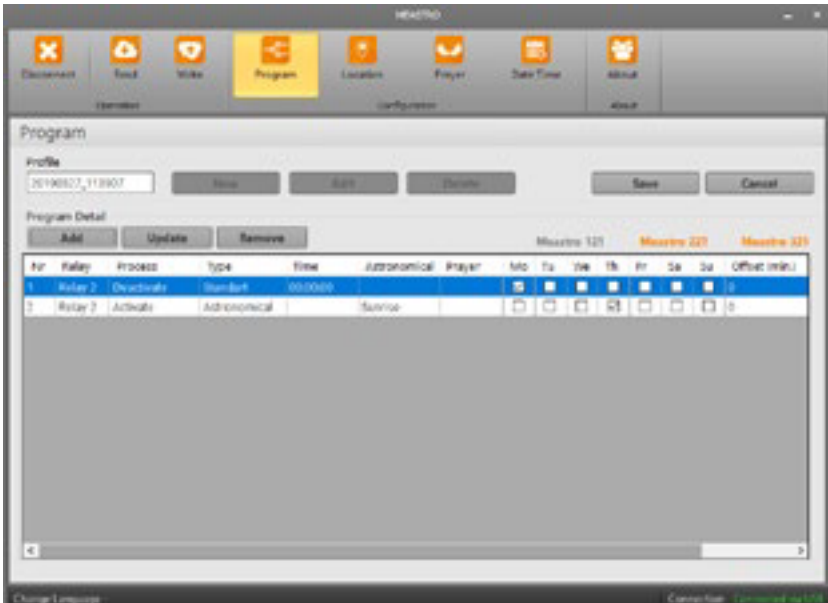

Figure 5-14 Meastro User Interface Program Program Tab

Note: Depending on the type of program added, the device names in the upper right corner will appear **orange** if the set type supports it. If the set program type does not support the device will appear **gray**.



Figure 5-15 Meastro User Interface Program Location Tab

In this tab, Meastro, Location Settings are set.

On the Location tab, the desired location settings are saved to the device, written to Meastro-R and transferred to the device.

The options under the 'Location' tab are divided into 3 sections: Selection, Custom and Daylight Saving.

The 'Location' Settings are done as follows, the 'New' box is clicked and the setting buttons are activated.

Profile: The name of the location setting to be created is written.

Select from List: The names of provinces and districts are selected.

Custom: The latitude and longitude information are written by user.

- **Region:** City name is written.
- **Sub-Region:** The name of the district is written.
- **Time zone:** The UTC settings with the entered position are selected from this section.

Day Light Saving: The method sections are as follows; Off, Europe, America and Custom.

Off: Daylight saving is turn off

Europe: It is set automatically when selected. Values cannot be changed by user.

America: It is set automatically when selected. Values cannot be changed by user.

Custom: Month, Week, Day and Time start and end settings are change by the user.

After settings, click on 'Save' button. Location settings are saved with the name written in Profile section.

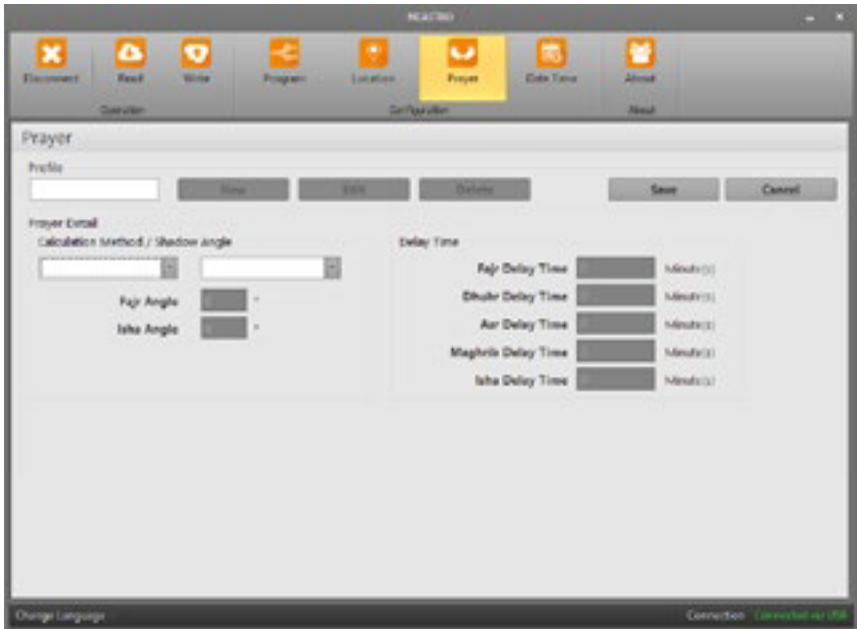

Figure 5-16 Meastro User Interface Program Pray Tab

In this tab, Meastro's Prayer Settings can configure.

In this tab user can set prayer and write on Meastro-R user can upload Meastro.

Note: Prayer setting is supported with Meastro-321.

The calculation method/shadow angle and delay times are set according to the position.

Prayer Settings will be set as follows,

Click '**New**' and the buttons are activated.

Calculation Method / Shadow Angle: The name of the region is selected where device is working.

When '**Custom**' select Fajr and Isha Angle will be configurable. For other region, interface directly sets the value. Shadow angle can be set to 1 ° and 2 °

Delay Time: Fajr-Dhuhr-Asr-Maghrib-Isha delay times are written by user.

After entering the values, click on 'Save' button. User can write all prayer settings on Meastro-R and user can upload Meastro.

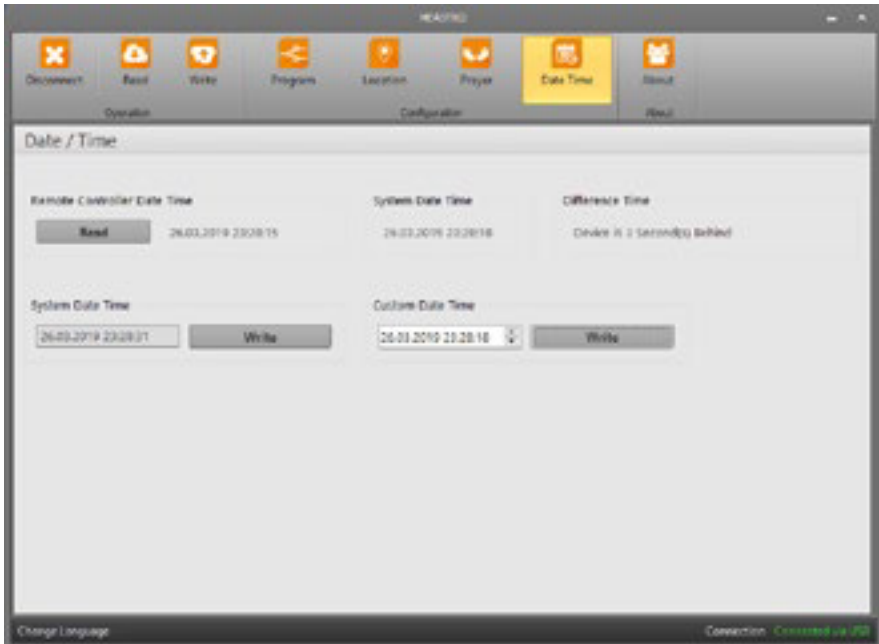

Figure 5-17 Meastro User Interface Program Date&Time Tab

In this tab, Meastro's Date Time Settings can configure.

Remote Controller Date Time: Displays the date and time in the infrared remote control and time on Meastro-R.

System Date Time: It shows the current date and time of the computer to which the infrared controller (Meastro-R) is connected.

Difference Time: It shows the time difference between the system and Infrared remote control (Maestro-R).

Custom Date Time: Date and time can be adjusted by user.

When clicked on the read button, the date and time in the infrared remote control is read.

- In system date time setting, time and date cannot be changed by user. Date and time information directly come from system.

- The values can be changed by the user in the Custom date and time setting.

By clicking **Write** button, the system date and time are written to the infrared control (Meastro-R).



Figure 5-18 Meastro User Interface Program About Tab

On About tab, user can find version of the device, Klemsan web address, mail address and office address information.

Offline Mod,



Figure 5-19 Connection Types Offline Configuration

The Offline Mode feature sets all the settings mentioned above without being connected to the device.

The interface allows the program to be kept in record.

When the device is connected programs are saved and can be transferred to the device.

5.2.2 Using Meastro User Interface Program with Meastro-RS485

User can configure Meastro with interface. Easy configuration with interface program for write date, time, program, location, prayer and device settings. User can load each setting via the interface to Meastro-RS 485. Also contains Log, Device information and Klemsan information.

- Select Meastro-RS 485 from interface.



Figure 5-20 Meastro RS-485 Select

After clicking on the Maestro-RS485 icon, user will see the following screen.



Figure 5-21 Connection Types

Select your connection type to communicate with Meastro-RS 485.

Click '**Connect via USB**' if user wants to communicate via serial connection.

Click '**Connect over TCP / IP**' if user wants to communicate via TCP/IP.

Offline Mode feature allows all settings be stored in the interface program without being connect to the device.

Select the device model which you use.

Connect with USB,



Figure 5-22 Connect with USB

If the correct port does not appear in the list when connecting to PC via USB cable, the list can be updated by clicking 'Refresh' button. Click on connect button after '**COM - X**' is selected.

Slave Id: The Slave Number of the communication device to which the Meastro-RS 485 is connected must be entered.

Baud Rate: The baud rate of the communication device to which the Meastro-RS 485 is connected must be entered.

After the values are entered correctly, click '**Connect**' button.

Connect over TCP/IP,

Click '**Connect via TCP / IP**'. After clicking, the following screenshot will appear.



Figure 5-23 Connect over TCP/IP

In this tab, values entered for the device that helps to communication between the computer and the device.

IP address: Meastro RS485 is connected the IP value of the communication device is entered.

Port: The Port value of the communication device to which the Meastro-RS485 is connected is entered.

Slave Id: The Slave No value of the communication device to which the Meastro-RS485 is connected is entered.

Timeout (ms): After the user-entered queries are asked from the serial line, they are expected to respond again.

The length of time the device will wait can be determined by this parameter.

Note:The descriptions on the following pages are valid for two connection types.



Figure 5-24 Meastro User Interface Program Date&Time Tab

In this tab, Meastro-RS 485's Date Time Settings are set.

Device Date Time: It shows the date and time on Meastro-RS485.

System Date Time: It shows the current date and time of the computer which communicated with device.

Difference Time: It shows the time difference between the system and Meastro-RS485.

Custom Date Time: Date and time can be adjusted by user.

Click '**Read**' button will read the date and time in Meastro-RS485

When clicked on the read button, the date and time in Meastro-RS 485 is read.

- In system date time setting, time and date cannot be changed by user. Date and time information directly come from system.

- The values can be changed by the user in the Custom date and time setting.

By clicking **Write** button, the system date and time are written to Meastro-RS485.



Figure 5-25 Meastro User Interface Program Program Tab

In this tab, Meastro-RS 485 Program Settings are made. Programs to be saved in the Program tab are created. Programs to set can be added, updated or removed via infrared control.

Program settings, desired days of the week Standard, Astro, Prayer time types Relay 1 (C1) - Relay 2 (C2) can be set as activate and passive.



Figure 5-26 Meastro User Interface Program Program Save Tab

Click the '**Add**' and the program detail page in the screenshot above appears. Click '**Save Program Detail**' button after setting the relevant relay. Otherwise registering the program, it will look like the following screenshot.

Nr: The created program number. It is possible to create up to 100 programs.

Relay: Relay is selected to activated or deactivate. Relay 1 (C1) or Relay 2 (C2).

Process: Relay which is select before, set activate or deactivate.

Type: It is the part where selected relay is run in time. This part divided into 3 part Standard, Astronomical and Prayer.

- **Standard**, settings are made by the user in hours, minutes and seconds.
- **Astronomical**, part runs depending on sunrise and sunset time.
- **Prayer**; device settings are made by selecting the time of Fajr-Dhuhr-Asr-Maghrib-Isha.

Offset (min): The time difference of the set time type. This section applies to Astro and Prayer.

Week Days: The program created for marked day will run.

Description: The definition and notes of the program are written in this section.

Click **'Save Program Detail'** button after setting the relevant relay. The screen will look like this after the program is registered,

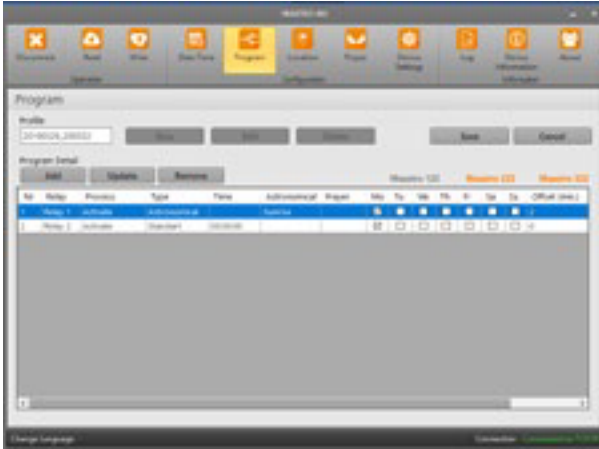

Figure 5-27 Meastro User Interface Program Program Tab

Note: Depending on the type of program added, the device names in the upper right corner will appear **orange** if the set type supports it. If the set program type does not support the device will appear **gray**.



Figure 5-28 Meastro User Interface Program Location Tab

In this tab, Meastro-RS 485 Location Settings can configure. In this tab user can set location and write on Meastro-RS 485.

The options under the Position tab consist of 3 parts: Selection from List, Custom and Daylight Saving.

Position Settings are as follows,

Click the '**New**' button and the setting buttons are activated.

Profile: The name of the location setting to be created is written.

Select from List: The names of provinces and districts are selected.

Custom: The latitude and longitude information are written by user.

- **Region:** City name is written.
- **Sub-Region:** The name of the district is written.
- **Time zone:** The UTC settings with the entered position are selected from this section.

Day Light Saving: The method sections are as follows; Off, Europe, America and Custom.

Off: Daylight saving is turned off

Europe: It is set automatically when selected. Values cannot be changed by user.

America: It is set automatically when selected. Values cannot be changed by user.

Custom: Month, Week, Day and Time start and end settings are changed by the user.

After settings, click on '**Save**' button. Location settings are saved with the name written in **Profile** section.



Figure 5-29 Meastro User Interface Program Prayer Tab

In this tab, Meastro's Prayer Settings can configure.

The calculation method/shadow angle and delay times are set according to the position.

Prayer Settings will be set as follows,

Click '**New**' and the buttons are activated.

Calculation Method / Shadow Angle: The name of the region is selected where device is working. When 'Custom' select Fajr and Isha Angle will be configurable. For other region, interface directly sets the value. Shadow angle can be set to 1° and 2°

Delay Time: Fajr-Dhuhr-Asr-Maghrib-Isha delay times are written by user.

After entering the values, click on 'Save' button. User can write all prayer settings on Meastro-RS 485.



Figure 5-30 Meastro User Interface Program Device Setting Tab

In this tab, Meastro-RS485's Device Settings can configure.

Under the tab General, Communication, Holiday Settings Relay 1 - Holiday Settings - Relay 2 and Commands consists of 4 adjustment parts.

General,

- **Language:** The language settings of the device can be set here.
- **Change Language** button in the lower left corner of the interface screen is the language setting of the interface program.
- **Contrast:** The device display contrast setting is set here.
- **Backlight:** This is the backlight setting of the device display.
- **Password:** The device password is created here.
- **Password Protection:** The device password protection is controlled to be active or inactive.

Holiday Settings Relay 1 and Holiday Settings Relay 2

The device is in the tab where holiday mode settings.

- **Start Date Time:** The date and time starts.
- **End Date Time:** This is the date and time when the set Holiday Program will end.
- **Relay Status at Start:** Holiday 1 mode is set to active or passive for Relay 1.
Holiday 2 mode is set to active or passive for relay 2.
- **Program State:** This is the section where the program is set to active or passive.

Communication

It is the section where the communication settings of the device are made.

Commands

Relay control via the interface is provided in the Commands section.

Operation Mode: Automatic mode, control of Relay 1 (C1) and Relay 2 (C2) buttons is automatically adjusted.

Manual mode is selected, Relay 1 (C1) and Relay 2 (C2) are controlled by user.

Note: When the user wants to change the relay position, the interface program directs the confirmation question to get the approval.

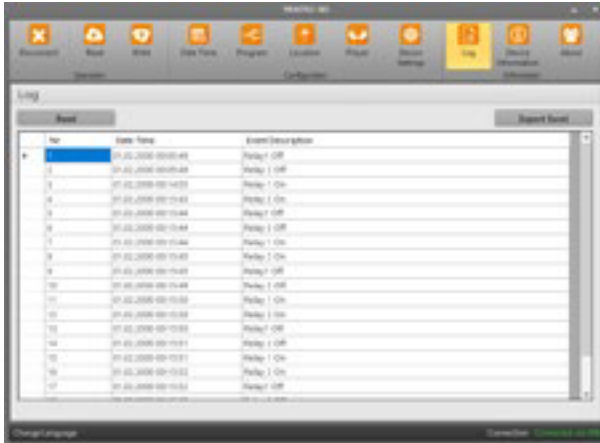

Figure 5-31 Meastro User Interface Program Log Tab

In this tab, there are recordings of Meastro-RS485 Log event.

Events performed with Meastro-RS485 are transferred to Excel file with description and time information.

If there is no event logging on the device, the event description in the interface appears empty.



Figure 5-32 Meastro User Interface Program Device InformationTab

This tab contains Device information.

On the Device info tab; Serial Number, Order Number, Production Date, Number of Relay Switching, Relay On-Off Time, Sunrise / Sunset Times, Prayer Time can be read on single screen.

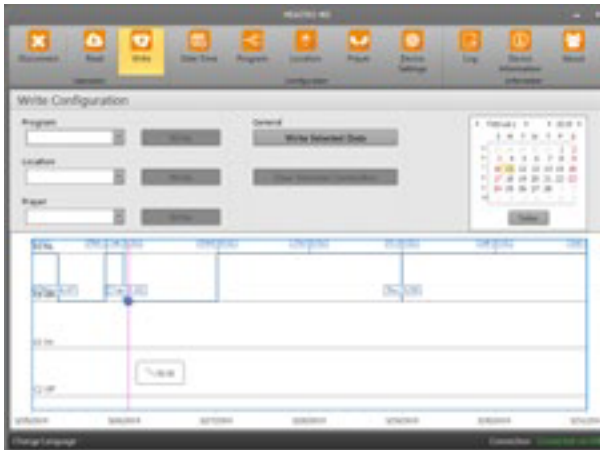

Figure 5-33 Meastro User Interface Program Write Tab

In this tab, the pre-recorded program, location and prayer status are selected. Relay 1 (C1) and Relay 2 (C2) are activated and passive can be read and analysed on the graph. In Read tab, data in the device can be read and analysed in the interface program.

The logo graphic consists of a central orange circle containing the word 'MEASTRO'. To the right of this circle is a complex, interconnected network of orange and dark blue shapes, resembling a molecular or circuit structure. Below this network is a large, dark blue circle containing the text 'BÖLÜM 6 MODBUS Protokolü' and 'SECTION 6 MODBUS Protocol'. The background is white.

MEASTRO

BÖLÜM 6
MODBUS Protokolü

SECTION 6
MODBUS Protocol

- **03H fonksiyonu/function:** Bu fonksiyon ile modbus tablosundaki okuma yapılabilen adresler okunur. /Reads the binary contents of holding registers (4X references) in Meastro.
- **6H fonksiyonu/function:** Bu fonksiyon ile modbus tablosundaki tek yazma yapılabilen adresler yazılır. /Presets a value into a single holding register (4X references).
- **10H fonksiyonu/function:** Bu fonksiyon ile modbus tablosundaki çoklu yazma yapılabilen adresler yazılır. /Presets a value into a multiplholding register (4X references).
- **11H fonksiyonu/function:** Bu fonksiyon ile modbus tablosundaki ürün bilgileri okunur. /Returns a status word and an event count from the Meastro's communications event counter.

Tanımlamalar/Definitions:

- **R / W:** Adresteki değer okunup, yazılabilir. /In that adress value can be read and write.
- **RO:** Adresteki değer sadece okunabilir. /In that adress value can be read.

Tablo 6-1 Modbus Table / Modbus Tablosu

Reading Product Information With 0x11 Function / 0x11 Fonksiyonu İle Ürün Bilgilerinin Okunması	
Name / Adı	Value / Değeri
Order Code / Sipariş Kodu	12 Bayt Char / 12 Byte Karakter
Serial Number / Seri Numarası	12 Bayt Char / 12 Byte Karakter
Firmware Version / Yazılım Versiyonu	12 Bayt Char / 12 Byte Karakter
PCB Version / PCB Versiyonu	12 Bayt Char / 12 Byte Karakter
Production Date / Üretim Tarihi	12 Bayt Char / 12 Byte Karakter
Run Indicator Status / Gösterge Durumunu Çalıştırma	0xFF (1 Byte, uint8) / 0xFF 1 Bayt, işaretsiz tamsayı 8

Item /Sayı	Adress /Adres	Variable /Parametre	Read /Write /Okuma /Yazma	Function /Fonksiyon	Data Type /Veri Tipi	Description /Açıklama	Example/Örnek	
							Value/ Değer	Description /Açıklama
General State / Genel Durum								
1	0	Operation Mode /Operasyon Modu	RO	0x03	unsigned	0: Manual / Manuel 1: Automatic / Otomatik	10110001111010	Each bit refers to program. (LSB Least Significant Byte) / Her bit bir programı ifade eder. (LSB en düşük numaralı programdır.)
2	1	Assigned Programs 1-16 /Atanan Programlar 1-16	RO	0x03	unsigned	0: Not assigned / Atanmamış 1: Assigned / Atanmış		
3	2	Assigned Programs 17-32 /Atanan Programlar 17-32	RO	0x03	unsigned	0: Not assigned / Atanmamış 1: Assigned / Atanmış		
4	3	Assigned Programs 33-48 /Atanan Programlar 33-48	RO	0x03	unsigned	0: Not assigned / Atanmamış 1: Assigned / Atanmış		

Item /Sayı	Adress /Adres	Variable /Parametre	Read /Write /Okuma /Yazma	Function /Fonksiyon	Data Type /Veri Tipi	Description /Açıklama	Example/Örnek	
							Value/ Değer	Description /Açıklama
5	4	Assigned Programs 49-64 /Atanan Programlar 49-64	RO	0x03	unsigned	0: Manual / Manuel 1: Automatic / Otomatik	10110001111010	Each bit refers to program. (LSB Least Significant Byte) / Her bit bir programı ifade eder. (LSB en düşük numaralı programdır.)
6	5	Assigned Programs 65-80 /Atanan Programlar 65-80	RO	0x03	unsigned	0: Not assigned / Atanmamış 1: Assigned / Atanmış		
7	6	Assigned Programs 81-96 /Atanan Programlar 81-96	RO	0x03	unsigned	0: Not assigned / Atanmamış 1: Assigned / Atanmış		
8	7	Assigned Programs 97-100 /Atanan Programlar 97-100	RO	0x03	unsigned	0: Not assigned / Atanmamış 1: Assigned / Atanmış		
9	8	Relay 1 State /Röle 1 Durum	RO	0x03	unsigned	0: Off / Kapalı 1: On / Açık		
10	9	Relay 2 State /Röle 2 Durum	RO	0x03	unsigned	0: Off / Kapalı 1: On / Açık		
Relay 1 Information / Röle 1 Bilgisi								
1	20	Relay 1 Switching Count /Röle 1 Anahtarlama Sayısı	RO	0x03	uint32_t			
2	22	Relay 1 On Time /Röle 1 Açık Kalma Süresi	RO	0x03	uint32_t	Hour / Saat		
3	24	Relay 1 Off Time /Röle 1 Kapalı Kalma Süresi	RO	0x03	uint32_t	Hour / Saat		
Relay 2 Information / Röle 2 Bilgisi								
1	26	Relay 2 Switching Count /Röle 2 Anahtarlama Sayısı	RO	0x03	uint32_t			
2	28	Relay 2 On Time /Röle 2 Açık Kalma Süresi	RO	0x03	uint32_t	Hour / Saat		
3	30	Relay 2 Off Time /Röle 2 Kapalı Kalma Süresi	RO	0x03	uint32_t	Hour / Saat		

Item /Sayı	Adress /Adres	Variable /Parametre	Read /Write /Okuma /Yazma	Fonksiyon	Data Type /Veri Tipi	Description /Açıklama	Example/Örnek	
							Value/ Değer	Description /Açıklama
Assigned Programs to Relay 1 / Rôle 1'e Atanan Programlar								
1	40	Assigned Programs 1-16 /Atanan Programlar 1-16	RO	0x03	unsigned	0: Manual / Manuel 1: Automatic / Otomatik	10110001111010	Each bit refers to program. (LSB Least Significant Byte) / Her bit bir programı ifade eder. (LSB en düşük numaralı programdır.)
2	41	Assigned Programs 17-32 /Atanan Programlar 17-32	RO	0x03	unsigned	0: Not assigned / Atanmamış 1: Assigned / Atanmış		
3	42	Assigned Programs 33-48 /Atanan Programlar 33-48	RO	0x03	unsigned	0: Not assigned / Atanmamış 1: Assigned / Atanmış		
4	43	Assigned Programs 49-64 /Atanan Programlar 49-64	RO	0x03	unsigned	0: Not assigned / Atanmamış 1: Assigned / Atanmış		
5	44	Assigned Programs 65-80 /Atanan Programlar 65-80	RO	0x03	unsigned	0: Not assigned / Atanmamış 1: Assigned / Atanmış		
6	45	Assigned Programs 81-96 /Atanan Programlar 81-96	RO	0x03	unsigned	0: Not assigned / Atanmamış 1: Assigned / Atanmış		
7	46	Assigned Programs 97-100 /Atanan Programlar 97-100	RO	0x03	unsigned	0: Not assigned / Atanmamış 1: Assigned / Atanmış		
Assigned Programs to Relay 2 / Rôle 2'e Atanan Programlar								
1	50	Assigned Programs 1-16 /Atanan Programlar 1-16	RO	0x03	unsigned	0: Manual / Manuel 1: Automatic / Otomatik	10110001111010	Each bit refers to program. (LSB Least Significant Byte) / Her bit bir programı ifade eder. (LSB en düşük numaralı programdır.)
2	51	Assigned Programs 17-32 /Atanan Programlar 17-32	RO	0x03	unsigned	0: Not assigned / Atanmamış 1: Assigned / Atanmış		
3	52	Assigned Programs 33-48 /Atanan Programlar 33-48	RO	0x03	unsigned	0: Not assigned / Atanmamış 1: Assigned / Atanmış		
4	53	Assigned Programs 49-64 /Atanan Programlar 49-64	RO	0x03	unsigned	0: Not assigned / Atanmamış 1: Assigned / Atanmış		
5	54	Assigned Programs 65-80 /Atanan Programlar 65-80	RO	0x03	unsigned	0: Not assigned / Atanmamış 1: Assigned / Atanmış		
6	55	Assigned Programs 81-96 /Atanan Programlar 81-96	RO	0x03	unsigned	0: Not assigned / Atanmamış 1: Assigned / Atanmış		
7	56	Assigned Programs 97-100 /Atanan Programlar 97-100	RO	0x03	unsigned	0: Not assigned / Atanmamış 1: Assigned / Atanmış		

Item /Sayı	Adress /Adres	Variable /Parametre	Read /Write /Okuma /Yazma	Function /Fonksiyon	Data Type /Veri Tipi	Description /Açıklama	Example/Örnek	
							Value/ Değer	Description /Açıklama
Event Logs / Olay Kayıtları								
1	100	Even 1 Type / Olay 1 Tipi	RO	0x03	unsigned	0: Empty / Boş 1: Relay 1 On / Röle 1 Açık 2: Relay 2 On / Röle 2 Açık 3: Relay 1 Off / Röle 1 Kapalı 4: Relay 2 Off / Röle 2 Kapalı 5: Daylight Saving Time Start / Yaz Saati Başlangıç 6: Daylight Saving Time End / Yaz Saati Bitiş	Value: 2	Relay 2 on at 22:17:58, 25/06/2018 / Röle 2 25/06/2018 saat 22:17:58'de aktif
2	101	Even 1 Hour / Olay 1 Saati	RO	0x03	unsigned	1 - 23	22	
3	102	Even 1 Minute / Olay 1 Dakika	RO	0x03	unsigned	0 - 59	17	
4	103	Even 1 Second / Olay 1 Saniye	RO	0x03	unsigned	0 - 59	58	
5	104	Even 1 Day / Olay 1 Gün	RO	0x03	unsigned	1 - 31	25	
6	105	Even 1 Month / Olay 1 Ay	RO	0x03	unsigned	1 - 12	6	
7	106	Even 1 Year / Olay 1 Yıl	RO	0x03	unsigned	0 - 99	18	
8	107	Even 2 Type / Olay 2 Tipi	RO	0x03	unsigned	0: Empty / Boş 1: Relay 1 On / Röle 1 Açık 2: Relay 2 On / Röle 2 Açık 3: Relay 1 Off / Röle 1 Kapalı 4: Relay 2 Off / Röle 2 Kapalı 5: Daylight Saving Time Start / Yaz Saati Başlangıç 6: Daylight Saving Time End / Yaz Saati Bitiş		
9	108	Even 2 Hour / Olay 2 Saati	RO	0x03	unsigned	1 - 23		
10	109	Even 2 Minute / Olay 2 Dakika	RO	0x03	unsigned	0 - 59		
11	110	Even 2 Second / Olay 2 Saniye	RO	0x03	unsigned	0 - 59		
12	111	Even 2 Day / Olay 2 Gün	RO	0x03	unsigned	1 - 31		
13	112	Even 2 Month / Olay 2 Ay	RO	0x03	unsigned	1 - 12		
14	113	Even 2 Year / Olay 2 Yıl	RO	0x03	unsigned	0 - 99		

Item /Sayı	Address /Adres	Variable /Parametre	Read /Write /Okuma /Yazma	Function /Fonksiyon	Data Type /Veri Tipi	Description /Açıklama	Example/Örnek	
							Value/ Değer	Description /Açıklama
Event Logs / Olay Kayıtları								
127	226	Even 19 Type / Olay 19 Tipi	RO	0x03	unsigned	0: Empty / Boş 1: Relay 1 On / Röle 1 Açık 2: Relay 2 On / Röle 2 Açık 3: Relay 1 Off / Röle 1 Kapalı 4: Relay 2 Off / Röle 2 Kapalı 5: Daylight Saving Time Start / Yaz Saati Başlangıç 6: Daylight Saving Time End / Yaz Saati Bitiş		
128	227	Even 19 Hour / Olay 19 Saati	RO	0x03	unsigned	1 - 23		
129	228	Even 19 Minute / Olay 19 Dakika	RO	0x03	unsigned	0 - 59		
130	229	Even 19 Second / Olay 19 Saniye	RO	0x03	unsigned	0 - 59		
131	230	Even 19 Day / Olay 19 Gün	RO	0x03	unsigned	1 - 31		
132	231	Even 19 Month / Olay 19 Ay	RO	0x03	unsigned	1 - 12		
133	232	Even 19 Year / Olay 19 Yıl	RO	0x03	unsigned	0 - 99		
134	233	Even 20 Type / Olay 20 Tipi	RO	0x03	unsigned	0: Empty / Boş 1: Relay 1 On / Röle 1 Açık 2: Relay 2 On / Röle 2 Açık 3: Relay 1 Off / Röle 1 Kapalı 4: Relay 2 Off / Röle 2 Kapalı 5: Daylight Saving Time Start / Yaz Saati Başlangıç 6: Daylight Saving Time End / Yaz Saati Bitiş		
135	234	Even 20 Hour / Olay 20 Saati	RO	0x03	unsigned	1 - 23		
136	235	Even 20 Minute / Olay 20 Dakika	RO	0x03	unsigned	0 - 59		
137	236	Even 20 Second / Olay 20 Saniye	RO	0x03	unsigned	0 - 59		
138	237	Even 20 Day / Olay 20 Gün	RO	0x03	unsigned	1 - 31		
139	238	Even 20 Month / Olay 20 Ay	RO	0x03	unsigned	1 - 12		
140	239	Even 20 Year / Olay 20 Yıl	RO	0x03	unsigned	0 - 99		

NOTE /NOT

All Event types are the same as given in the description. Event parameters should be read in groups of 7. Otherwise, the device will give an "Invalid data address" error." The difference between the start address of the Modbus query and the first address of the event must be 7 times. Otherwise, the device will give an "Invalid data address" error.
/ Tüm Olay tipleri açıklamadaki ile aynıdır. Olay parametreleri Modbus ile 7'li gruplar halinde okunmalıdır. Aksi takdirde cihaz "Invalid data adres" hatası verecektir. Modbus sorgu başlangıç adresi ile olayın ilk kayıt adresi arasındaki fark 7' nin katı olmak zorundadır. Aksi takdirde cihaz "Invalid data adres" hatası verecektir.

Item /Sayı	Adress /Adres	Variable /Parametre	Read /Write /Okuma /Yazma	Function /Fonksiyon	Data Type /Veri Tipi	Description /Açıklama	Example/Örnek	
							Value/ Değer	Description /Açıklama
Sunrise - Sunset Times / Gün Doğumu - Gün Batımı Zamanları								
1	300	Sunrise Hour / Gün Doğum Saat	RO	0x03	unsigned	1 - 23	6	Sunrise, 06:35:00 /Gün Doğumu 06:35:00
2	301	Sunrise Minute / Gün Doğum Dakika	RO	0x03	unsigned	0- 59	35	
3	302	Sunrise Second / Gün Doğum Saniye	RO	0x03	unsigned	0 - 59	0	
4	303	Sunset Hour / Gün Batımı Saat	RO	0x03	unsigned	1 - 23	20	Sunset, 20:22:00 /Gün Batımı 20:22:00
5	304	Sunset Minute / Gün Batımı Dakika	RO	0x03	unsigned	0- 59	22	
6	305	Sunset Second / Gün Batımı Saniye	RO	0x03	unsigned	0 - 59	0	

NOTE /NOT

Sunset and sunrise parameters should be read in groups of 3. Otherwise, the device will give an "Invalid data address" error. The difference between the start address of the Modbus query and the first address of the event must be 3 times. Otherwise, the device will give an "Invalid data address" error.
/Günbatımı ve Gündoğumu parametreleri 3 lü gruplar halinde okunmalıdır. Aksi taktirde cihaz "Invalid data adres" hatası verecektir. Modbus sorgu başlangıç adresi ile olayın ilk adresi arasındaki fark 3 ün katı olmak zorundadır. Aksi taktirde cihaz "Invalid data adres" hatası verecektir.

Item /Sayı	Adress /Adres	Variable /Parametre	Read /Write /Okuma /Yazma	Function /Fonksiyon	Data Type /Veri Tipi	Description /Açıklama	Example/Örnek	
							Value/ Değer	Description /Açıklama
Prayer Times / Namaz Vakitleri								
1	400	Fajr Hour / İmsak Saat	RO	0x03	unsigned	1 - 23	6	Fajr 06:35:00 /İmsak 06:35:00
2	401	Fajr Minute / İmsak Dakika	RO	0x03	unsigned	0- 59	35	
3	402	Fajr Second / İmsak Saniye	RO	0x03	unsigned	0 - 59	0	
4	403	Dhuhr Hour / Öğle Saat	RO	0x03	unsigned	1 - 23	13	Dhuhr 13:02:00 / Öğle 13:02:00
5	404	Dhuhr Minute / Öğle Dakika	RO	0x03	unsigned	0- 59	2	
6	405	Dhuhr Second / Öğle Saniye	RO	0x03	unsigned	0 - 59	0	
7	406	Asr Hour / İkinci Saat	RO	0x03	unsigned	1 - 23	16	Asr 16:35:00 /İkinci 16:35:00
8	407	Asr Minute / İkinci Dakika	RO	0x03	unsigned	0- 59	35	
9	408	Asr Second / İkinci Saniye	RO	0x03	unsigned	0 - 59	0	
10	409	Magrib Hour / Akşam Saat	RO	0x03	unsigned	1 - 23	20	Magrib 20:22:00 /Akşam 20:22:00
11	410	Magrib Minute / Akşam Dakika	RO	0x03	unsigned	0- 59	22	
12	411	Magrib Second / Akşam Saniye	RO	0x03	unsigned	0 - 59	0	
13	412	Isha Hour / Yatsı Saat	RO	0x03	unsigned	1 - 23	22	Isha 22:20:00 /Yatsı 22:20:00
14	413	Isha Minute / Yatsı Dakika	RO	0x03	unsigned	0- 59	20	
15	414	Isha Second / Yatsı Saniye	RO	0x03	unsigned	0 - 59	0	

NOTE /NOT

These parameters should be read in groups of 3. Otherwise, the device will give an "Invalid data address" error. The difference between the start address of the Modbus query and the first address of the event must be 3 times. Otherwise, the device will give an "Invalid data address" error.
/Bu parametreler 3 lü gruplar halinde okunmalıdır. Aksi taktirde cihaz "Invalid data adres" hatası verecektir. Modbus sorgu başlangıç adresi ile olayın ilk adresi arasındaki fark 3 ün katı olmak zorundadır. Aksi taktirde cihaz "Invalid data adres" hatası verecektir.

Item /Sayı	Adress /Adres	Variable /Parametre	Read /Write /Okuma /Yazma	Function /Fonksiyon	Data Type /Veri Tipi	Description /Açıklama	Example/Örnek	
							Value/ Değer	Description /Açıklama
Relay 1 Holiday Address Start/Röle 1 Tatil Adres Başlangıç - 500					Relay 2 Holiday Address Start/Röle 2 Tatil Adres Başlangıç - 600			
Holiday Settings / Tatil Ayarları								
1	500	Relay 1 Start Hour /Röle 1 Başlangıç Saat	R/W	0x03 - 0x10	unsigned	1 - 23		
2	501	Relay 1 Start Minute /Röle 1 Başlangıç Dakika	R/W	0x03 - 0x10	unsigned	0 - 59		
3	502	Relay 1 Start Second /Röle 1 Başlangıç Saniye	R/W	0x03 - 0x10	unsigned	0 - 59		
4	503	Relay 1 Start Day /Röle 1 Başlangıç Gün	R/W	0x03 - 0x10	unsigned	1 - 31		
5	504	Relay 1 Start Month /Röle 1 Başlangıç Ay	R/W	0x03 - 0x10	unsigned	1 - 12		
6	505	Relay 1 Start Year /Röle 1 Başlangıç Ay	R/W	0x03 - 0x10	unsigned	0 - 99		
7	506	Relay 1 End Hour /Röle 1 Bitiş Saat	R/W	0x03 - 0x10	unsigned	1 - 23		
8	507	Röle 1 End Minute /Röle 1 Bitiş Dakika	R/W	0x03 - 0x10	unsigned	0 - 59		
9	508	Relay 1 End Second /Röle 1 Bitiş Saniye	R/W	0x03 - 0x10	unsigned	0 - 59		
10	509	Relay 1 End Day /Röle 1 Bitiş Gün	R/W	0x03 - 0x10	unsigned	1 - 31		
11	510	Relay 1 End Month /Röle 1 Bitiş Ay	R/W	0x03 - 0x10	unsigned	1 - 12		
12	511	Relay 1 End Year /Röle 1 Bitiş Yıl	R/W	0x03 - 0x10	unsigned	0 - 99		
13	512	Relay 1 State at Start /Röle 1 Başlangıç Durumu	R/W	0x03 - 0x10	unsigned	0: Relay Off at Start /Başlangıçta Röle Kapalı 1: Relay On at Start /Başlangıçta Röle Açık		
14	513	Relay 1 Program State /Röle 1 Program Durumu	R/W	0x03 - 0x10	unsigned	0: Program Deactive /Program Deaktif 1: Program Active /Program Aktif		
15	600	Relay 2 Start Hour /Röle 2 Başlangıç Saat	R/W	0x03 - 0x10	unsigned	1 - 23		
16	601	Relay 2 Start Minute /Röle 2 Başlangıç Dakika	R/W	0x03 - 0x10	unsigned	0 - 59		
17	602	Relay 2 Start Second /Röle 2 Başlangıç Saniye	R/W	0x03 - 0x10	unsigned	0 - 59		
18	603	Relay 2 Start Day /Röle 2 Başlangıç Gün	R/W	0x03 - 0x10	unsigned	1 - 31		
19	604	Relay 2 Start Month /Röle 2 Başlangıç Ay	R/W	0x03 - 0x10	unsigned	1 - 12		

Item /Sayı	Address /Adres	Variable /Parametre	Read /Write /Okuma /Yazma	Function /Fonksiyon	Data Type /Veri Tipi	Description /Açıklama	Example/Örnek	
							Value/ Değer	Description /Açıklama
Holiday Settings / Tatil Ayarları								
20	605	Relay 2 Start Year /Röle 2 Başlangıç Ay	R/W	0x03 - 0x10	unsigned	0 - 99		
21	606	Relay 2 End Hour /Röle 2 Bitiş Saat	R/W	0x03 - 0x10	unsigned	1 - 23		
22	607	Röle 2 End Minute /Röle 2 Bitiş Dakika	R/W	0x03 - 0x10	unsigned	0 - 59		
23	608	Relay 2 End Second /Röle 2 Bitiş Saniye	R/W	0x03 - 0x10	unsigned	0 - 59		
24	609	Relay 2 End Day /Röle 2 Bitiş Gün	R/W	0x03 - 0x10	unsigned	1 - 31		
25	610	Relay 2 End Month /Röle 2 Bitiş Ay	R/W	0x03 - 0x10	unsigned	1 - 12		
26	611	Relay 2 End Year /Röle 2 Bitiş Yıl	R/W	0x03 - 0x10	unsigned	0 - 99		
27	612	Relay 2 State at Start /Röle 2 Başlangıç Durumu	R/W	0x03 - 0x10	unsigned	0: Relay Off at Start /Başlangıçta Röle Kapalı 1: Relay On at Start /Başlangıçta Röle Açık		
28	613	Relay 2 Program State /Röle 2 Program Durumu	R/W	0x03 - 0x10	unsigned	0: Program Deactive /Program Deaktif 1: Program Active /Program Aktif		

NOTE /NOT

These parameters should be read / written in groups of 14. Otherwise, the device will give an "Invalid data address" error. The difference between the start address of the Modbus query and the first address of the event must be 3 times. Otherwise, the device will give an "Invalid data address" error.
/Bu parametreler 14 lü gruplar halinde okunmalıdır / yazılmalıdır. Aksi takdirde cihaz "Invalid data adres" hatası verecektir. Modbus sorgu başlangıç adresi ile olayın ilk adresi arasındaki fark 3 ün katı olmak zorundadır. Aksi takdirde cihaz "Invalid data adres" hatası verecektir.

Item /Sayı	Adress /Adres	Variable /Parametre	Read /Write /Okuma /Yazma	Function /Fonksiyon	Data Type /Veri Tipi	Description /Açıklama	Example/Örnek	
							Value/ Değer	Description /Açıklama
Device Settings / Cihaz Ayarları								
1	700	Language / Dil	R/W	0x03 - 0x10	unsigned	0: Turkish / <i>Türkçe</i> 1: English / <i>İngilizce</i>		
2	701	Contrast / Kontrast	R/W	0x03 - 0x10	unsigned	0: Contrast Level 1 1: Contrast Level 2 2: Contrast Level 3 3: Contrast Level 4 4: Contrast Level 5 5: Contrast Level 6 6: Contrast Level 7 7: Contrast Level 8		
3	702	Backlight Time /Arkaplan Işık Zamanı	R/W	0x03 - 0x10	unsigned	0: Allways On / <i>Sürekli Açık</i> 1: Always Off / <i>Sürekli Kapalı</i> 2: 10 Seconds On / <i>10 Saniye Açık</i> 3: 60 Seconds On / <i>60 Saniye Açık</i> 4: 600 Seconds On / <i>600 Saniye Açık</i>		
4	703	Password Digit 1 /Şifre 1. Dijit	R/W	0x03 - 0x10	unsigned	0 - 9		
5	704	Password Digit 2 /Şifre 2. Dijit	R/W	0x03 - 0x10	unsigned	0 - 9		
6	705	Password Digit 3 /Şifre 3. Dijit	R/W	0x03 - 0x10	unsigned	0 - 9		
7	706	Password Digit 4 /Şifre 4. Dijit	R/W	0x03 - 0x10	unsigned	0 - 9		
8	707	Password Protection State /Şifre Koruması Durumu	R/W	0x03 - 0x10	unsigned	0: Protection Deactive / <i>Koruma Kapalı</i> 1: Protection Active / <i>Koruma Açık</i>		
Serial Configuration Settings / Seri Haberleşme Ayarları								
1	800	Slave Id / Köle Id	R/W	0x03 - 0x10	unsigned	1 - 254		
2	801	Baudrate / Baudrate	R/W	0x03 - 0x10	unsigned	0- 1200 1- 2400 2- 4800 3- 9600 7- 19200 5- 38400 6- 57600 7- 115200		

Item /Sayı	Adress /Adres	Variable /Parametre	Read /Write /Okuma /Yazma	Function /Fonksiyon	Data Type /Veri Tipi	Description /Açıklama	Example/Örnek	
							Value/Değer	Description /Açıklama
Date Time Setting / Zaman Saat Ayarları								
1	900	Hour / Saat	R/W	0x03 - 0x10	unsigned	1 - 23	11	
2	901	Minute / Dakika	R/W	0x03 - 0x10	unsigned	0 - 59	21	
3	902	Second / Saniye	R/W	0x03 - 0x10	unsigned	0 - 59	0	
4	903	Day / Gün	R/W	0x03 - 0x10	unsigned	1 - 31	25	
5	904	Month / Ay	R/W	0x03 - 0x10	unsigned	1 - 12	6	
6	905	Year / Yıl	R/W	0x03 - 0x10	unsigned	0 - 99	18	11:21:00, 25/06/2018, Monday
7	906	Day of week / Haftanın Günü	RO	0x03	unsigned	1: Monday /Pazartesi 2: Tuesday /Salı 3: Wednesday /Çarşamba 4: Thursday /Perşembe 5: Friday /Cuma 6: Saturday /Cumartesi 7: Sunday /Pazar	1	/11:21:00, 25/06/2018, Pazartesi

NOTE /NOT

These parameters should be read in groups of 7 and written in groups of 6. Otherwise, the device will give an "Invalid data address" error. Modbus query has to be starting address 900. Otherwise, the device will give an "Invalid data address" error. /Bu parametreler 7 lü gruplar halinde okunmalı ve 6 lü gruplar halinde yazılmalıdır. Aksi takdirde cihaz "Invalid data adress" hatası verecektir. Modbus sorgu başlangıç adresi '900' olmak zorundadır. Aksi takdirde cihaz "Invalid data adress" hatası verecektir.

Item /Sayı	Adress /Adres	Variable /Parametre	Read /Write /Okuma /Yazma	Function /Fonksiyon	Data Type /Veri Tipi	Description /Açıklama	Example/Örnek	
							Value/Değer	Description /Açıklama
Konum Ayarları / Location Settings								
1	907	Latitude Sign /Enlem İşareti	R/W	0x03 - 0x10	unsigned	0: + (Positive / Pozitif) 1: - (Negative / Negatif)		
2	908	Latitude Integer Part /Enlem Tamsayı Kısmı	R/W	0x03 - 0x10	unsigned	0 - 88		
3	909	Latitude Fractional Part /Enlem Kesirli Kısım	R/W	0x03 - 0x10	unsigned	0 - 99		
4	910	Longitude Sign /Boylam İşareti	R/W	0x03 - 0x10	unsigned	0: + (Positive / Pozitif) 1: - (Negative / Negatif)		
5	911	Longitude Integer Part /Boylam Tamsayı Kısım	R/W	0x03 - 0x10	unsigned	0 - 179		
6	912	Longitude Fractional Part /Boylam Kesirli Kısım	R/W	0x03 - 0x10	unsigned	0 - 99		
7	913	Selected Region /Seçilen İl	R/W	0x03 - 0x10	unsigned	0 - 80		

Item /Sayı	Adress /Adres	Variable /Parametre	Read /Write /Okuma /Yazma	Function /Fonksiyon	Data Type /Veri Tipi	Description /Açıklama	Example/Örnek	
							Value/ Değer	Description /Açıklama
Konum Ayarları / Location Settings								
8	914	Selected Subregion /Seçilen İlçe	R/W	0x03 - 0x10	unsigned	Subregion Number of Selected Region / Seçilen İlın İlçe Numarası		
9	915	Location Type /Konum Tipi	R/W	0x03 - 0x10	unsigned	0 - 88		
10	916	Utc Sign /Evensel Zaman İşareti	R/W	0x03 - 0x10	unsigned	0 - 99		
11	917	Utc Hour /Evensel Zaman Saat	R/W	0x03 - 0x10	unsigned	0: + (Positive / Pozitif) 1: - (Negative / Negatif)		
12	918	Utc Minute /Evensel Zaman Dakika	R/W	0x03 - 0x10	unsigned	0 - 59		

NOTE /NOT

NOTE: Location setting parameters should be read as a group of 7 and written as a group of 6. Otherwise, the device will give an "Invalid data address" error. The initial address of location setting with the Modbus query start address must be '914'. Otherwise, the device will give an "Invalid data address" error.

NOTE*:if selected Location Type 0; the latitude, longitude, region and subregion parameters are automatically written and cannot be changed by user. If selected Location Type 1; the latitude and longitude parameters must be written by the user.

NOT: Konum ayar parametreleri 7 li grup halinde okunmalıdır ve 6 lı grup halinde yazılmalıdır. Aksi taktirde cihaz "Invalid data adress" hatası verecektir. Modbus sorgu başlangıç adresi ile konum ayar ilk adresi değeri '914' olmak zorundadır. Aksi taktirde cihaz "Invalid data adress" hatası verecektir.

NOT*: Konum Tipi 0, seçilirse enlem, boylam, region ve subregion parametreleri otomatik olarak yazıldığı için kullanıcı tarafından değiştirilemez. Konum Tipi 1, seçilirse ise enlem ve boylam parametreleri kullanıcı tarafından yazılmalıdır.

Item /Sayı	Adress /Adres	Variable /Parametre	Read /Write /Okuma /Yazma	Function /Fonksiyon	Data Type /Veri Tipi	Description /Açıklama	Example/Örnek	
							Value/ Değer	Description /Açıklama
Konum Ayarları / Location Settings								
13	919	Utc Second /Evensel Zaman Saniye	R/W	0x03 - 0x10	unsigned	0 - 59		
14	920	Region Name //İl Adı	R/W	0x03 - 0x10	char16byte	ASCII		
15	928	Subregion Name //İlçe Adı	R/W	0x03 - 0x10	char16byte	ASCII		

NOTE /NOT

These parameters should be read / written in groups of 29. Otherwise, the device will give an "Invalid data address" error. If selected Location Type 0; the latitude, longitude, region and subregion parameters are automatically written and cannot be changed by user. If selected Location Type 1; the latitude and longitude parameters must be written by the user.

/Bu parametreler 29lu gruplar halinde okunmalıdır. "Konum Tipi" 0 seçilirse enlem, boylam, il ve ilçe verileri otomatik olarak yazılacaktır. Eğer "Konum Tipi" 1 seçilmiş ise enlem ve boylam parametreleri yazılmalıdır.

Region Number // Numarası	Region //ller	County Counts (Subregion) //lçe Numarası	Subregions //lçeler	Region Number // Numarası	Region //ller	County Counts (Subregion) //lçe Numarası	Subregions //lçeler
This table refers to address 920 and 928. / Bu tablo 920 ve 928. adres deęerleriyle ilgilidir.							
0	ADANA	3	MERKEZ FEKE POZANTI	14	BURDUR	2	MERKEZ ALTINYAYLA
1	ADIYAMAN	3	MERKEZ GERGER GOLBASI	15	BURSA	5	MERKEZ HARMANCIK INEGOL IZNIK KARACABEY
2	AFYONKARAHISAR	3	MERKEZ DINAR EMIRDAĞ	16	CANAKKALE	3	MERKEZ GOKCEADA YENICE
3	AGRI	3	MERKEZ DOGUBEYAZIT PATNOS	17	CANKIRI	1	MERKEZ
4	AMASYA	1	MERKEZ	18	CORUM	2	MERKEZ KARGI
5	ANKARA	10	MERKEZ BALA BEYPAZARI CUBUK HAYMANA KALECIK KIZILCAHAMAM NALLIHAN POLATLI SEREFLIKOCHISAR	19	DENIZLI	3	MERKEZ CAMELI CIVRIL
				20	DIYARBAKIR	3	MERKEZ CUNGUS KULP
				21	EDIRNE	2	MERKEZ KESAN
				22	ELAZIG	2	MERKEZ KARAKOCAN
6	ANTALYA	9	MERKEZ ALANYA FINIKE GAZIPASA KAS KEMER KORKUTELI KUMLUCA MANAVGAT	23	ERZINCAN	2	MERKEZ KEMALIYE
				24	ERZURUM	3	MERKEZ HORASAN OLUR
				25	ESKISEHIR	2	MERKEZ SIVRIHISAR
				26	GAZIANTEP	1	MERKEZ
7	ARTVIN	1	MERKEZ	27	GIRESUN	2	SEBINKARAHISAR MERKEZ
8	AYDIN	4	MERKEZ DIDIM KUSADASI NAZILLI	28	GUMUSHANE	1	MERKEZ
				29	HAKKARI	1	MERKEZ
9	BALIKESIR	4	MERKEZ AYVALIK BANDIRMA DURSUNBEY	30	HATAY	2	MERKEZ ISKENDERUN
				31	ISPARTA	2	MERKEZ YALVAC
10	BILECIK	1	MERKEZ	32	MERSIN	3	MERKEZ ANAMUR SILIFKE
11	BINGOL	1	MERKEZ				
12	BITLIS	2	MERKEZ ADILCEVAZ	33	ISTANBUL	3	MERKEZ SILIVRI SILE
13	BOLU	2	MERKEZ GOYNUK				

Region Number // Numarası	Region //İller	County Counts (Subregion) //İlçe Numarası	Subregions //İlçeler	Region Number // Numarası	Region //İller	County Counts (Subregion) //İlçe Numarası	Subregions //İlçeler
This table refers to address 920 and 928. / Bu tablo 920 ve 928. adres değerleriyle ilgilidir.							
34	IZMIR	5	MERKEZ BERGAMA KEMALPASA ODEMIS URLA	55	SIIRT	1	MERKEZ
				56	SINOP	1	MERKEZ
35	KARS	1	MERKEZ	57	SIVAS	3	MERKEZ GURUN SUSEHRI
36	KASTAMONU	1	MERKEZ	58	TEKIRDAG	2	MERKEZ CORLU
37	KAYSERI	1	MERKEZ	59	TOKAT	1	MERKEZ
38	KIRKLARELI	1	MERKEZ	60	TRABZON	2	MERKEZ CAYKARA
39	KIRSEHIR	1	MERKEZ	61	TUNCELI	1	MERKEZ
40	KOCAELI	3	MERKEZ GEBZE IZMIT	62	SANLIURFA	1	MERKEZ
				63	USAK	1	MERKEZ
41	KONYA	5	MERKEZ AKSEHIR BEYSEHIR CIHANBEYLI EREGLI	64	VAN	1	MERKEZ
				65	YOZGAT	1	MERKEZ
42	KUTAHYA	2	MERKEZ SIMAV	66	ZONGULDAK	1	MERKEZ
43	MALATYA	2	MERKEZ DARENDE	67	AKSARAY	1	MERKEZ
44	MANISA	3	MERKEZ ALASEHIR DEMIRCI	68	BAYBURT	1	MERKEZ
				69	KARAMAN	1	MERKEZ
45	KAHRAMANMARAS	1	MERKEZ	70	KIRIKKALE	1	MERKEZ
46	MARDIN	1	MERKEZ	71	BATMAN	1	MERKEZ
47	MUGLA	4	MERKEZ BODRUM FETHIYE MARMARIS	72	SIRNAK	1	MERKEZ
				73	BARTIN	1	MERKEZ
48	MUS	1	MERKEZ	74	ARDAHAN	1	MERKEZ
49	NEVSEHIR	1	MERKEZ	75	IGDIR	1	MERKEZ
50	NIGDE	1	MERKEZ	76	YALOVA	1	MERKEZ
51	ORDU	1	MERKEZ	77	KARABUK	1	MERKEZ
52	RIZE	1	MERKEZ	78	KILIS	1	MERKEZ
53	SAKARYA	1	MERKEZ	79	OSMANIYE	1	MERKEZ
54	SAMSUN	2	MERKEZ VEZIRKOPRU	80	DUZCE	1	MERKEZ

Item /Sayı	Adress /Adres	Variable /Parametre	Read /Write /Okuma /Yazma	Function /Fonksiyon	Data Type /Veri Tipi	Description /Açıklama	Example/Örnek	
							Value/ Değer	Description /Açıklama
Daylight Saving Time Settings / Yaz Saati Uygulaması Ayarları								
1	936	Mode / Mod	R/W	0x03 - 0x10	unsigned	0- Off / Kapalı 1- Europa / Avrupa 2- USA / Amerika 3- Custom / Özel	0-Daylight saving time is off. /Yaz saati uygulaması kapalı durumdadır. 1-2 -Values cannot be changed by user./Değerler sabit olarak gelir kullanıcı tarafından değiştirilemez. 3-Value cannot be changed by user. /Değerler kullanıcı tarafından ayarlanır.	
2	937	Start Month/Başlangıç Ay	R/W	0x03 - 0x10	unsigned	1 - 12	3	
3	938	Start Week/ Başlangıç Hafta	R/W	0x03 - 0x10	unsigned	0- Week 1 / 1. Hafta 1- Week 2 / 2. Hafta 2- Week 3 / 3. Hafta 3- Week 4 / 4. Hafta 4- Last week / Son Hafta	4	4.th week of March Sunday /Martın 4.haftası Pazar günü
4	939	Start Day / Başlangıç Gün	R/W	0x03 - 0x10	unsigned	1- 31	7	
5	940	Start Hour / Başlangıç Saat	R/W	0x03 - 0x10	unsigned	1 - 23	3	
6	941	Start Minute / Başlangıç Dakika	R/W	0x03 - 0x10	unsigned	0 - 59	0	03:00:00
7	942	Start Second / Başlangıç Saniye	R/W	0x03 - 0x10	unsigned	0 - 59	0	
8	943	End Month / Bitiş Ay	R/W	0x03 - 0x10	unsigned	1 - 12	10	
9	944	Start Week/ Başlangıç Hafta	R/W	0x03 - 0x10	unsigned	0- Week 1 / 1. Hafta 1- Week 2 / 2. Hafta 2- Week 3 / 3. Hafta 3- Week 4 / 4. Hafta 4- Last week / Son Hafta	4	4.th week of October Sunday/Ekimin 4.haftası Pazar günü
10	945	End Day / Bitiş Gün	R/W	0x03 - 0x10	unsigned	1- 31	7	
11	946	End Hour / Bitiş Saat	R/W	0x03 - 0x10	unsigned	1 - 23	3	
12	947	End Minute / Bitiş Dakika	R/W	0x03 - 0x10	unsigned	0 - 59	0	03:00:00
13	948	End Second / Bitiş Saniye	R/W	0x03 - 0x10	unsigned	0 - 59	0	

NOTE /NOT

These parameters should be read / written in groups of 13. Otherwise, the device will give an "Invalid data address" error. The start and end data should always be written. However, for data other than Custom, these values will be ignored.
/Bu sayfadaki parametreler 13 lü grup halinde okunmalıdır / yazılmalıdır. Aksi takdirde cihaz "Invalid data adres" hatası verecektir. Start ve end verileri her zaman yazılmalıdır. Ancak Custom seçeneği dışındaki verilerde bu değerler göz ardı edilecektir.

Item /Sayı	Adress /Adres	Variable /Parametre	Read /Write /Okuma /Yazma	Function /Fonksiyon	Data Type /Veri Tipi	Description /Açıklama	Example/Örnek	
							Value/ Değer	Description /Açıklama
Prayer Settings / Namaz Ayarları								
1	949	Calculation Angle Fajr Integer /Açı Hesaplama İmsak Tamsayı Kısım	R/W	0x03 - 0x10	unsigned	0 - 25		
2	950	Calculation Angle Fajr Fractional /Açı Hesaplama İmsak Kesirli Kısım	R/W	0x03 - 0x10	unsigned	0 - 99		
3	951	Calculation Angle Isha Integer /Açı Hesaplama Yatsı Tamsayı Kısım	R/W	0x03 - 0x10	unsigned	0 - 25		
4	952	Calculation Angle Fajr Fractional /Açı Hesaplama İmsak Kesirli Kısım	R/W	0x03 - 0x10	unsigned	0 - 99		
5	953	Calculation Method /Hesaplama Metodu	R/W	0x03 - 0x10	unsigned	0- MWL / MWL 1- ISNA / ISNA 2- EGYPT / MISIR 3- MAKKAH / MEKKE 4- KARACHI / KARACHI 5- TEHRAN / TAHRAN 6- JAFARI / CAFERI 7- CUSTOM / ELLE		
6	954	Shadow Factor /Gölge Faktörü	R/W	0x03 - 0x10	unsigned	0: 1 degree / 1 Derece 1: 2 degree / 2 Derece		
7	955	Fajr Margin Sign /İmsak Marjın İşareti	R/W	0x03 - 0x10	unsigned	0: + (Positive / Pozitif) 1: - (Negative / Negatif)		
8	956	Fajr Margin Minute /İmsak Marjın Dakika	R/W	0x03 - 0x10	unsigned	0: 1 degree / 1 Derece 1: 2 degree / 2 Derece		
9	957	Dhuhr Margin Sign /Öğle Marjın İşareti	R/W	0x03 - 0x10	unsigned	0: + (Positive / Pozitif) 1: - (Negative / Negatif)		
10	958	Dhuhr Margin Minute /Öğle Marjın Dakika	R/W	0x03 - 0x10	unsigned	0: 1 degree / 1 Derece 1: 2 degree / 2 Derece		
11	959	Asr Margin Sign /İkindi Marjın İşareti	R/W	0x03 - 0x10	unsigned	0: + (Positive / Pozitif) 1: - (Negative / Negatif)		
12	960	Asr Margin Minute /İkindi Marjın Dakika	R/W	0x03 - 0x10	unsigned	0: 1 degree / 1 Derece 1: 2 degree / 2 Derece		
13	961	Magrib Margin Sign /Akşam Marjın İşareti	R/W	0x03 - 0x10	unsigned	0: + (Positive / Pozitif) 1: - (Negative / Negatif)		
14	962	Magrib Margin Minute /Akşam Marjın Dakika	R/W	0x03 - 0x10	unsigned	0 - 15		

Item /Sayı	Adress /Adres	Variable /Parametre	Read /Write /Okuma /Yazma	Function /Fonksiyon	Data Type /Veri Tipi	Description /Açıklama	Example/Örnek	
							Value/ Değer	Description /Açıklama
Prayer Settings / Namaz Ayarları								
15	963	Isha Margin Sign /Yatsı Marjın İşareti	R/W	0x03 - 0x10	unsigned	0: + (Positive / Pozitif) 1: - (Negative / Negatif)		
16	964	Isha Margin Minute / Yatsı Marjın Dakika	R/W	0x03 - 0x10	unsigned	0 - 15		

NOTE /NOT

Prayer settings parameters should be read / written in groups of 18. Otherwise, the device will give an "Invalid data address" error. If "Calculation Method" selected as "Custom", values should be entered between 954-694.
/Namaz ayarlar parametreleri 18 li grup halinde okunmalıdır / yazılmalıdır. Aksi takdirde cihaz "Invalid data adress" hatası verecektir. "Hesaplama Metodu" "Elle" olarak seçilirse 954-964 arasındaki değerler girilmelidir.

Item /Sayı	Adress /Adres	Variable /Parametre	Read /Write /Okuma /Yazma	Function /Fonksiyon	Data Type /Veri Tipi	Description /Açıklama	Example/Örnek	
							Value/ Değer	Description /Açıklama
Programs / Programlar								
1	2000	Program 1 Time Value 1 / Program 1 Zaman Değeri 1	R/W	0x03 - 0x10	unsigned	Type Standart: Hour / Saat (1 - 23) Type Astro: 0: Sunrise / Gün Doğum 1: Sunset / Gün Batım Type Prayer: 0: Fajr / İmsak 1: Dhuh / Öğle 2: Asr / İkindi 3: Magrib / Akşam 4: Isha / Yatsı	0	Because of Standard Type /Program Standart Tip olduğu için
2	2001	Program 1 Time Value 2 / Program 1 Zaman Değeri 2	R/W	0x03 - 0x10	unsigned	Type Standart: Minute / Dakika (0 - 59) Type Astro: NA (0) Type Prayer: NA (0)	0	
3	2002	Program 1 Time Value 2 / Program 1 Zaman Değeri 2	R/W	0x03 - 0x10	unsigned	Type Standart: Minute / Dakika (0 - 59) Type Astro: NA (0) Type Prayer: NA (0)	1	00:00:01
4	2003	Program 1 Minute Offset / Program 1 Offset Dakika	R/W	0x03 - 0x10	signed	-720 .. 720	0	
5	2004	Program 1 Weekdays / Program 1 Günler	R/W	0x03 - 0x10	unsigned	2: Monday / Pazartesi 4: Tuesday / Salı 8: Wednesday / Çarşamba 16: Thursday / Perşembe 32: Friday / Cuma 64: Saturday / Cumartesi 128: Sunday / Pazar	Value: 00000000 11111110	The bits that are 1 express the day of the week. The data in the example means that all days of the week are selected. The selected days can be found by adding or by bit operations. /1 olan bitler haftanın günün ifade eder. Örnekteki veri haftanın tüm günlerinin seçildiği anlamındadır. Seçilen günler toplanarak veya bit işlemleri ile bulunabilir.

Item /Sayı	Adress /Adres	Variable /Parametre	Read /Write /Okuma /Yazma	Function /Fonksiyon	Data Type /Veri Tipi	Description /Açıklama	Example/Örnek	
							Value/ Değer	Description /Açıklama
Programs / Programlar								
6	2005	Program 1 Type / Program 1 Tip	R/W	0x03 - 0x10	unsigned	0: Standart 1: Astro 2: Prayer	0	
7	2006	Program 1 Relay Number / Program 1 Röle Numarası	R/W	0x03 - 0x10	unsigned	0: Relay 1 1: Relay 2	0	Relay 1/Röle1
8	2007	Program 1 Relay State / Program 1 Röle Durumu	R/W	0x03 - 0x10	unsigned	0: Relay Deactive / Röle Kapalı 1: Relay Active / Röle Açık	1	Activate program /Program açık
9	2008	Program 1 Program State / Program 1 Program Durumu	R/W	0x03 - 0x10	unsigned	0: Deactive Program / Program Kapalı 1: Activate Program / Program Açık	1	Activate program /Program açık
10	2009	Program 2 Time Value 1 / Program 2 Zaman Değeri 1	R/W	0x03 - 0x10	unsigned	Type Standart: Hour / Saat (1 - 23) Type Astro: 0: Sunrise / Gün Doğum 1: Sunset / Gün Batım Type Prayer: 0: Fajr / İmsak 1: Dhuhr / Öğle 2: Asr / İkinci 3: Magrib / Akşam 4: Isha / Yatsı		
11	2010	Program 2 Time Value 2 / Program 2 Zaman Değeri 2	R/W	0x03 - 0x10	unsigned	Type Standart: Minute / Dakika (0 - 59) Type Astro: NA (0) Type Prayer: NA (0)		
12	2011	Program 2 Time Value 3 / Program 2 Zaman Değeri 3	R/W	0x03 - 0x10	unsigned	Type Standart: Minute / Dakika (0 - 59) Type Astro: NA (0) Type Prayer: NA (0)		
13	2012	Program 2 Time Value 3 / Program 2 Zaman Değeri 3	R/W	0x03 - 0x10	unsigned	-720 .. 720		
14	2013	Program 1 Weekdays / Program 1 Günler	R/W	0x03 - 0x10	unsigned	2: Monday / Pazartesi 4: Tuesday / Salı 8: Wednesday / Çarşamba 16: Thursday / Perşembe 32: Friday / Cuma 64: Saturday / Cumartesi 128: Sunday / Pazar		
15	2014	Program 2 Type / Program 2 Tip	R/W	0x03 - 0x10	unsigned	0: Standart 1: Astro 2: Prayer		
16	2015	Program 2 Relay Number / Program 2 Röle Numarası	R/W	0x03 - 0x10	unsigned	0: Relay 1 1: Relay 2		

Item /Sayı	Adress /Adres	Variable /Parametre	Read /Write /Okuma /Yazma	Function /Fonksiyon	Data Type /Veri Tipi	Description /Açıklama	Example/Örnek	
							Value/ Değer	Description /Açıklama
Programs / Programlar								
17	2016	Program 2 Relay State / Program 2 Röle Durumu	R/W	0x03 - 0x10	unsigned	0: Relay Deactive / Röle Kapalı 1: Relay Active / Röle Açık		
18	2017	Program 2 Program State / Program 2 Program Durumu	R/W	0x03 - 0x10	unsigned			
Up to 100 programs can be written. / 100 programa kadar yazılabilir.								
NOTE /NOT	All programs are the same as the First Program descriptions. The difference between the start address of the Modbus query and the address of the program must be 9 times. Otherwise, the device will give an "Invalid data address" error. Program parameters should be read in groups of 9. Otherwise, the device will give an "Invalid data address" error. /Tüm programlar 1. Programın açıklamaları ile aynıdır. Program parametreleri 9 lu gruplar halinde okunmalıdır. Aksi takdirde cihaz "Invalid data adress" hatası verecektir. Modbus sorgu başlangıç adresi ile program ilk adresi arasındaki fark 9 un katı olmak zorundadır. Aksi takdirde cihaz "Invalid data adress" hatası verecektir.							
Item /Sayı	Adress /Adres	Variable /Parametre	Read /Write /Okuma /Yazma	Function /Fonksiyon	Data Type /Veri Tipi	Description /Açıklama	Example/Örnek	
							Value/ Değer	Description /Açıklama
Programs / Programlar								
892	2891	Program 100 Time Value 1/ Program 100 Zaman Değeri 1	R/W	0x03 - 0x10	unsigned	Type Standart: Hour / Saat (1 - 23) Type Astro: 0: Sunrise / Gün Doğum 1: Sunset / Gün Batım Type Prayer: 0: Fajr / İmsak 1: Dhuhr / Öğle 2: Asr / İkindi 3: Magrib / Akşam 4: Isha / Yatsı		
893	2892	Program 100 Time Value 2 / Program 100 Zaman Değeri 2	R/W	0x03 - 0x10	unsigned	0: Deactive Program / Program Kapalı 1: Activate Program / Program Açık		
894	2893	Program 100 Time Value 3/ Program 100 Zaman Değeri 3	R/W	0x03 - 0x10	unsigned	Type Standart: Minute / Dakika (0 - 59) Type Astro: NA (0) Type Prayer: NA (0)		
895	2894	Program 100 Minute Offset/ Program 100 Offset Dakika	R/W	0x03 - 0x10	unsigned	-720 .. 720		
896	2895	Program 100 Weekdays / Program 100 Günler	R/W	0x03 - 0x10	unsigned	2: Monday / Pazartesi 4: Tuesday / Salı 8: Wednesday / Çarşamba 16: Thursday / Perşembe 32: Friday / Cuma 64: Saturday / Cumartesi 128: Sunday / Pazar		
897	2896	Program 100 Type / Program 100 Tip	R/W	0x03 - 0x10	unsigned	0: Standart 1: Astro 2: Prayer		

Item /Sayı	Adress /Adres	Variable /Parametre	Read /Write /Okuma /Yazma	Function /Fonksiyon	Data Type /Veri Tipi	Description /Açıklama	Example/Örnek	
							Value/ Değer	Description /Açıklama
Programs / Programlar								
898	2897	Program 100 Relay Number/ Program 100 Röle Numarası	R/W	0x03 - 0x10	unsigned	0: Relay 1 1: Relay 2		
899	2898	Program 100 Relay State / Program 100 Röle Durumu	R/W	0x03 - 0x10	unsigned	0: Relay Deactive / Röle Kapalı 1: Relay Active / Röle Açık		
900	2899	Program 100 Program State/ Program 100 Program Durumu	R/W	0x03 - 0x10	unsigned	0: Deactivate Program / Program Kapalı 1: Activate Program / Program Açık		

NOTE /NOT

All programs are the same as the First Program descriptions. The difference between the start address of the Modbus query and the address of the program must be 9 times. Otherwise, the device will give an "Invalid data address" error. Program parameters should be read in groups of 9. Otherwise, the device will give an "Invalid data address" error.
Tüm programlar 1. Programın açıklamaları ile aynıdır. Program parametreleri 9 lu gruplar halinde okunmalıdır. Aksi taktirde cihaz "Invalid data adress" hatası verecektir. Modbus sorgu başlangıç adresi ile program ilk adresi arasındaki fark 9 un katı olmak zorundadır. Aksi taktirde cihaz "Invalid data adress" hatası verecektir.

Item /Sayı	Adress /Adres	Variable /Parametre	Read /Write /Okuma /Yazma	Function /Fonksiyon	Data Type /Veri Tipi	Description /Açıklama	Example/Örnek	
							Value/ Değer	Description /Açıklama
Programs / Programlar								
1	3000	General Commdar / Genel Komutlar	W/O	0x06	unsigned	13568: Save Programs Programlar Kayıt 13569: Save Location / Konum Kayıt 13570: Save Prayer / Namaz Kayıt 13571: Save Daylight Saving / Yaz Saati Kayıt 13572: Save Holiday 1 / Tatil 1 Kayıt 13573: Save Holiday 2 / Tatil 2 Kayıt 13574: Save Device Setting / Cihaz Ayarları Kayıt 13575: Save Serial Conf. Seri Haberleşme Kayıt 13576: Clear Programs Programları Sil 13577: Clear Logs / Kayıtları Sil 13578: Relay1 Counters / Röle 1 Sayıcı 13579: Relay2 Counters / Röle 2 Sayıcı 13580: Factory Settings / Fabrika Ayarları		
2	3001	Program Clear / Program Sil	W/O	0x06	unsigned	Program Number / Program Numarası (1 - 100)		

Item /Sayı	Adress /Adres	Variable /Parametre	Read /Write /Okuma /Yazma	Function /Fonksiyon	Data Type /Veri Tipi	Description /Açıklama	Example/Örnek	
							Value/ Değer	Description /Açıklama
Programs / Programlar								
3	4000	Operation Mode / Operasyon Modu	W/O	0x06	unsigned	13568: Manual / Manuel 13569: Automatic / Otomatik		
4	4001	Relay 1 State (Operates only Manual Mode) Röle 1 Durum (Sadece Manuel Mod İçin)	W/O	0x06	unsigned	13568: Relay off /Röle Kapalı 13569: Relay on /Röle Açık		
5	4002	Relay 2 State (Operates only Manual Mode) Röle 2 Durum (Sadece Manuel Mod İçin)	W/O	0x06	unsigned	13568: Relay off /Röle Kapalı 13569: Relay on /Röle Açık		



Kızılızüm Mahallesi Kemalpaşa Kızılızüm Cad. No:15 - 35730
Kemalpaşa - İzmir / TURKEY Tel: (+90 232) 877 08 00 Fax: (+90 232) 877 08 06

www.klemsan.com / info@klemsan.com.tr

Klemsan[®]
Revizion No: 08022021