

Inclinometers

For dynamic applications 1- and 2-axis measurement	IN78	CANopen
---	-------------	----------------



The inclinometers of the IN78 series are used to determine 2-axis inclinations in the measuring range of $\pm 85^\circ$ or 1-axis inclinations up to 360° via a sensor fusion of acceleration and rotation rate measuring cell (gyroscope). Various parameters can be customized for individual requirements. Thanks to their high robustness, the inclinometers are also ideally suited for outdoor use.



Features and benefits

- **Individual setting options**
 - Reset to factory setting
 - Center of the measurement as well as start and end point for 1-axis measurement
 - Switching the spirit level function on/off
 - Settings on the measuring range
 - Filter settings
- **Fast measurement result and high accuracy**

Thanks to sensor fusion of acceleration and rotation rate measuring cell (gyroscope). This also minimizes the effects of vibrations and interfering accelerations.
- **Simple start-up and diagnostics**

LED display for operating status and CANopen communication as well as for setting the center point position (spirit level function).
- **Precise measurement even under harsh environmental conditions**
 - Temperature range $-40^\circ\text{C} \dots +85^\circ\text{C}$ and protection level IP68 / IP69k
 - Protection against the influence of salt spray and rapid temperature changes

Order code 1-axis	<table border="1" style="border-collapse: collapse; width: 100%;"> <tr> <td style="width: 20%; text-align: center;">8.IN78</td> <td style="width: 5%; text-align: center;">.</td> <td style="width: 5%; text-align: center;">1</td> <td style="width: 5%; text-align: center;">7</td> <td style="width: 5%; text-align: center;">2</td> <td style="width: 5%; text-align: center;">1</td> <td style="width: 5%; text-align: center;">.</td> <td style="width: 5%; text-align: center;">11</td> <td style="width: 5%; text-align: center;">X</td> </tr> <tr> <td style="text-align: center; font-size: small;">Type</td> <td></td> <td></td> <td style="text-align: center; font-size: x-small;">a</td> <td style="text-align: center; font-size: x-small;">b</td> <td></td> <td></td> <td></td> <td style="text-align: center; font-size: x-small;">c</td> </tr> </table>	8.IN78	.	1	7	2	1	.	11	X	Type			a	b				c
8.IN78	.	1	7	2	1	.	11	X											
Type			a	b				c											
<p>a Measuring range 7 = $0^\circ \dots 360^\circ (\pm 180^\circ)$</p> <p>b Interface 2 = CANopen</p> <p>c Type of connection 2 = 1 x M12 connector, 5-pin 3 = 2 x M12 connector, 5-pin</p> <p style="font-size: small;">Stock types IN78.1721.113</p>																			

Order code 2-axis	<table border="1" style="border-collapse: collapse; width: 100%;"> <tr> <td style="width: 20%; text-align: center;">8.IN78</td> <td style="width: 5%; text-align: center;">.</td> <td style="width: 5%; text-align: center;">2</td> <td style="width: 5%; text-align: center;">6</td> <td style="width: 5%; text-align: center;">2</td> <td style="width: 5%; text-align: center;">1</td> <td style="width: 5%; text-align: center;">.</td> <td style="width: 5%; text-align: center;">11</td> <td style="width: 5%; text-align: center;">X</td> </tr> <tr> <td style="text-align: center; font-size: small;">Type</td> <td></td> <td></td> <td style="text-align: center; font-size: x-small;">a</td> <td style="text-align: center; font-size: x-small;">b</td> <td></td> <td></td> <td></td> <td style="text-align: center; font-size: x-small;">c</td> </tr> </table>	8.IN78	.	2	6	2	1	.	11	X	Type			a	b				c
8.IN78	.	2	6	2	1	.	11	X											
Type			a	b				c											
<p>a Measuring range 6 = $\pm 85^\circ$</p> <p>b Interface 2 = CANopen</p> <p>c Type of connection 2 = 1 x M12 connector, 5-pin 3 = 2 x M12 connector, 5-pin</p> <p style="font-size: small;">Stock types IN78.2721.113</p>																			

Inclinometers

For dynamic applications 1- and 2-axis measurement		IN78	CANopen
Accessories			Order no.
Adapter plate	For using existing mounting holes when replacing with an IS40 inclinometer	8.0010.4066.0000	
EMC shield terminal	For an EMC-compliant installation of the cable - top-hat rail mounting - spring steel, galvanized - shield diameter 3.0 ... 12.0 mm	8.0000.4G06.0312	
Cables and connectors			Order no.
Preassembled cables	M12 female connector with coupling nut for Bus in, 5-pin, A coded, straight single ended 5 m [16.40'] PVC cable	05.00.6091.A211.005M	
	M12 male connector with external thread for Bus out, 5-polig, A coded, straight single ended 5 m [16.40'] PVC cable	05.00.6091.A411.005M	
	M12 female connector with coupling nut for Bus in, 5-polig, A coded, straight Deutsch connector, 6-pin, DT04 1 m [3.28'] PVC cable	05.00.6091.22C7.001M	
Connectors	M12 female conn. with coupling nut for Bus in, 5-pin, A coded, straight (metal/plastic)	05.B-8151-0/9	
	M12 male conn. with external thread for Bus out, 5-pin, A coded, straight (metal/plastic)	05.BS-8151-0/9	

Further Kübler accessories can be found at: kuebler.com/accessories
 Further Kübler cables and connectors can be found at: kuebler.com/connection-technology

Inclinometers

For dynamic applications 1- and 2-axis measurement	IN78	CANopen
---	-------------	----------------

Technical data

General data 1-axis measurement	
Measuring range	0 ... 360°
Resolution	0.01°
Repeat accuracy	≤ 0.1°
Temperature drift	≤ ±0.02 %/K
Linearity deviation	≤ ±0.15%
Accuracy (at 25°C)	≤ ±0.54°

General data 2-axis measurement	
Measuring range (max.)	-85 ... +85°
Resolution	0.01°
Repeat accuracy	≤ 0.1°
Temperature drift	≤ ±0.02 %/K
Linearity deviation	≤ ±0.15%
Accuracy (at 25°C)	≤ ±0.1° depending on the measuring range

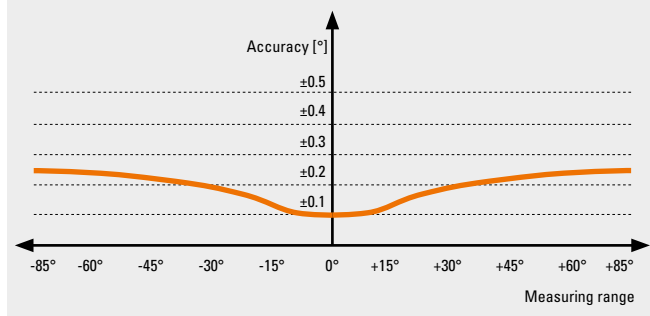

Mechanical characteristics	
Electrical connection	M12 connectors, 5-pin
Weight	89 g [3.14 oz]
Protection acc. to EN 60529	IP68 / IP69k
Working temperature range	-40 °C ... +85 °C [-40 °F ... +185 °F]
Material	housing Plastic, polyetherimide
Vibration resistance (EN 60068-2-6)	20 g; 5 h/axis; 3 axes
Shock resistance (EN 60068-2-27)	150 g; 4 ms 1/2 sine
MTTF	339 years acc. to SN 29500 (Ed. 99) 40 °C
Dimensions	71.6 x 62.6 x 20 mm [2.82 x 2.46 x 0.79"]

Electrical characteristics	
Supply voltage	8 ... 36 V DC
Residual ripple	≤ 10 % U _{ss}
Isolation test voltage	≤ 0.5 kV
Wire breakage / Reverse polarity protection	yes
Current consumption	max. 50 mA

Interface characteristics CANopen	
Communication protocol	CANopen
Node ID	1 ... 127; factory setting: 10
Baud rate	125 / 250 / 500 / 1000 kbit/s factory setting 500 kbit/s

Approvals	
UL compliant in accordance with	File-Nr. E539414
CE compliant in accordance with	
EMV Directive	2014/30/EU
RoHS Directive	2011/65/EU

Inclinometers

For dynamic applications 1- and 2-axis measurement	IN78	CANopen
---	-------------	----------------

Terminal assignment

Interface	2 x M12 connector, male contacts, 5-pin					
2 CANopen	Bus OUT					
	Signal:	+V	0 V	CAN_GND	CAN_H	CAN_L
	Pin:	2	3	1	4	5
	Bus IN					
	Signal:	+V	0 V	CAN_GND	CAN_H	CAN_L
	Pin:	2	3	1	4	5

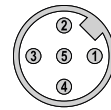
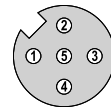
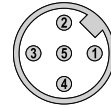

Dimensions

Dimensions in mm [inch]

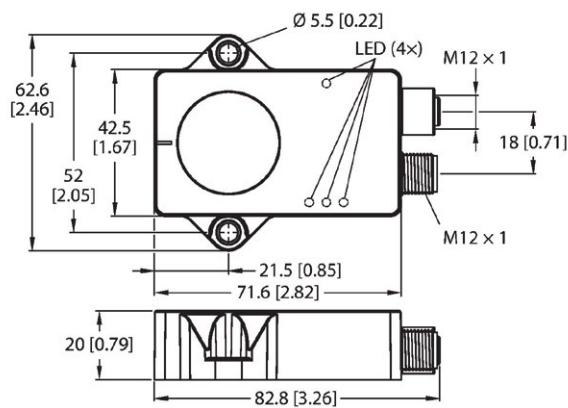

Inclinometers

For dynamic applications 1- and 2-axis measurement	IN78	CANopen
---	-------------	----------------

Technology in detail

Fast measurement results and maximum accuracy thanks to sensor fusion of acceleration and rotation rate measurement

Acceleration measurement

In the acceleration measuring cell, the absolute angular position is determined capacitively in relation to the gravity acceleration \vec{g} .

The displacement **2** of a test mass **1** changes the distance and therefore also the capacity **F** between fixed **3** and moving **4** electrodes in the measuring cell. This measured capacity is directly related to the inclination of the sensor.

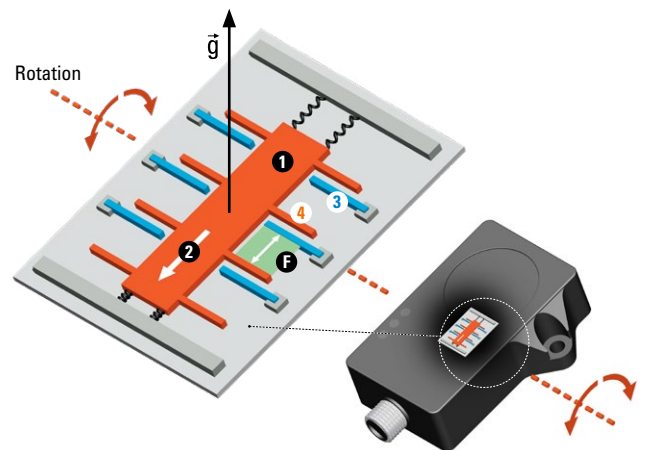
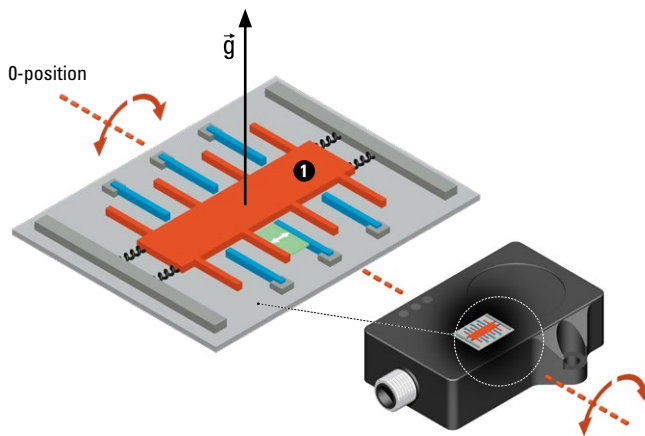

Rotation rate measurement

In the rotation rate measuring cell (gyroscope), the Coriolis force resulting from a rotation is evaluated in order to determine the angle of rotation in relation to the starting position.

This displacement is also determined by the change in capacity **F** between fixed and moving electrodes and is directly related to the rotational speed (rotation rate).

An arrangement of frame **2** and test mass **1** is in a permanent linear movement **3** (oscillating).

The angle of rotation is determined from the speed of rotation and the duration of rotation.

If this system is brought into rotation, this results in a force (Coriolis force) **4** that leads to a displacement of the test mass.

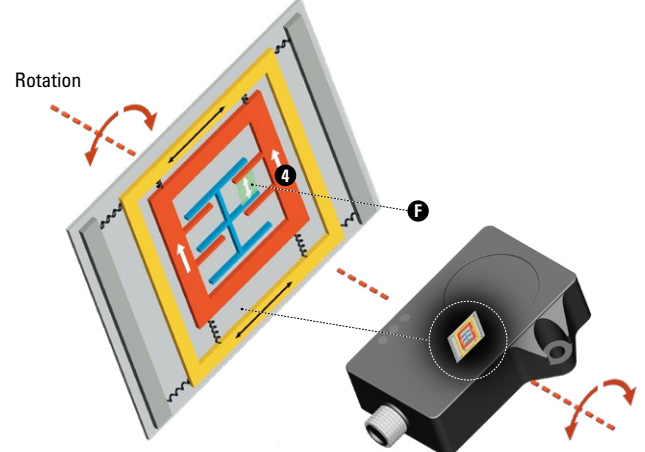
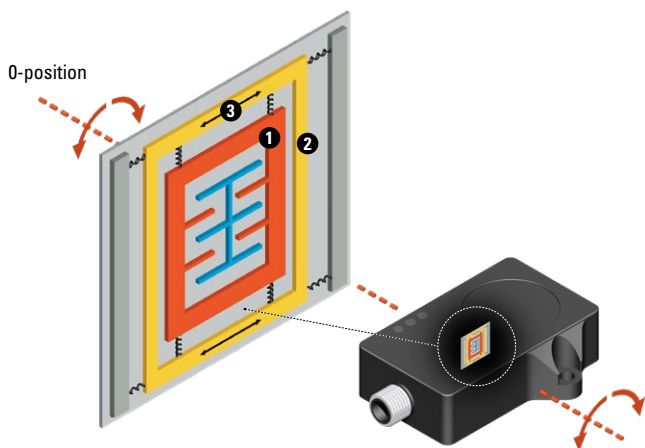

Intelligent sensor fusion of acceleration and rotation rate measurement

Both measured values are combined in the inclinometers for dynamic applications. The effect is even faster and more accurate output results.



Inclinometers

For dynamic applications
1- and 2-axis measurement

IN78

CANopen

Technology in detail

Comparison static inclinometer (accelerometer only) - dynamic inclinometer (sensor fusion)

Fast measurement

Inaccuracies due to the inertia of the test mass can be compensated for in acceleration measurement via filters. However, there is a time delay Δt for the output of the measurement result. This time delay is minimized with sensor fusion.

Acceleration measuring cell (static)

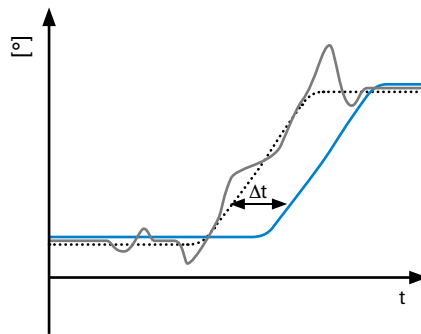

Sensor fusion (dynamic)

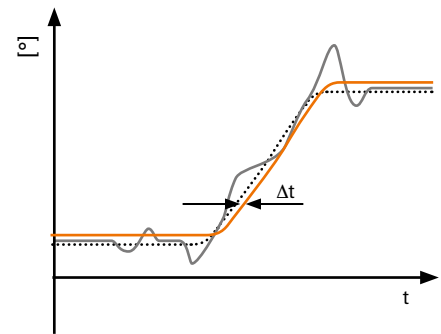

Accurate measurement

The sensor fusion leads to more accurate measurement results when changing direction quickly.

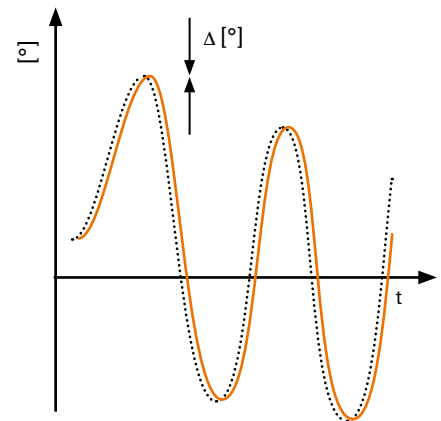
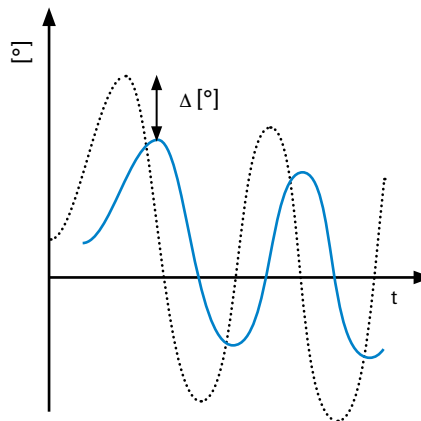

- Actual movement
- Detected data of the acceleration measurement
- Filtered measurement results of the acceleration measurement
- Result sensor fusion of acceleration and rotation rate measurement

Easy start-up

Operating status – LED green / red

Permanent light green	Appliance ready for operation Staus CANopen
Permanent light red	Error CANopen



1-axis = 3 LEDs

Spirit level function – LED(s) yellow

Permanent light	Center position reached
Blinking with increasing frequency	Approaching the center position
Blinking with decreasing frequency	Move away from center position



2-axis = 4 LEDs

