

N01R550-MC1526 (Order no. 091001)

Precision single limit switch N01, roller plunger, plug connector M12

- ▶ Plunger material stainless steel
- ▶ For plug connector with LED display

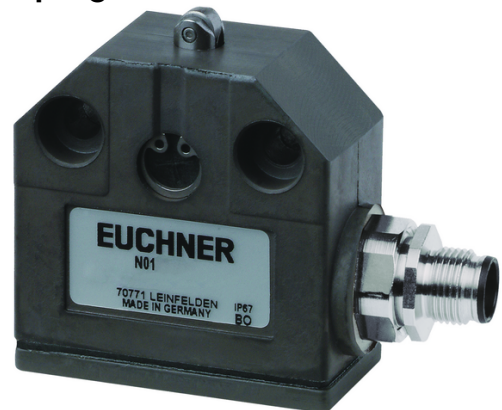

Dimensional drawings

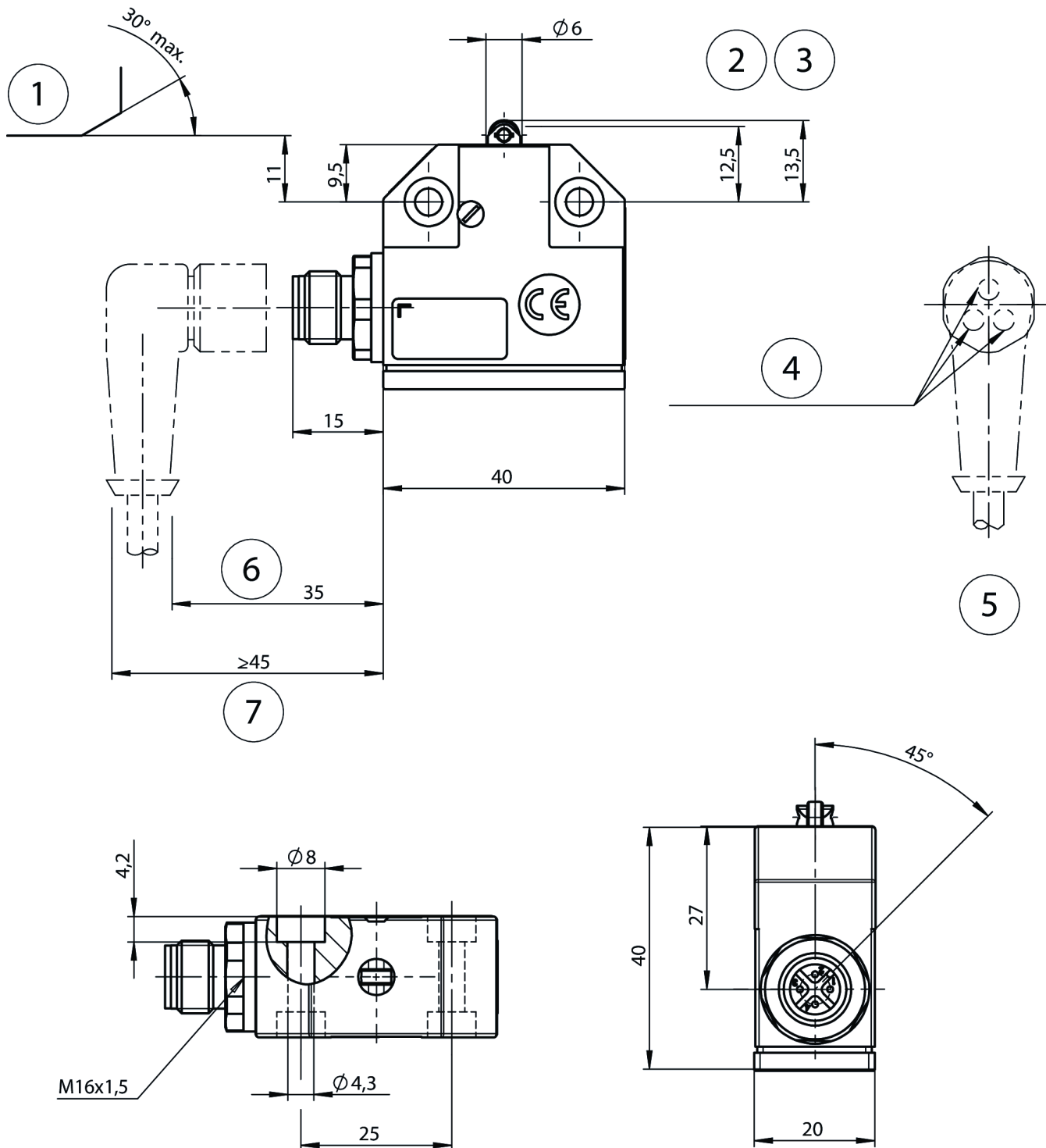

- 1 Dog
- 2 Operating point
- 3 Free position
- 4 Indicator light right-angle plug connector
- 5 Guide lug aligned
- 6 In the inserted and screwed tight state
- 7 Right-angle plug connector

Connection examples

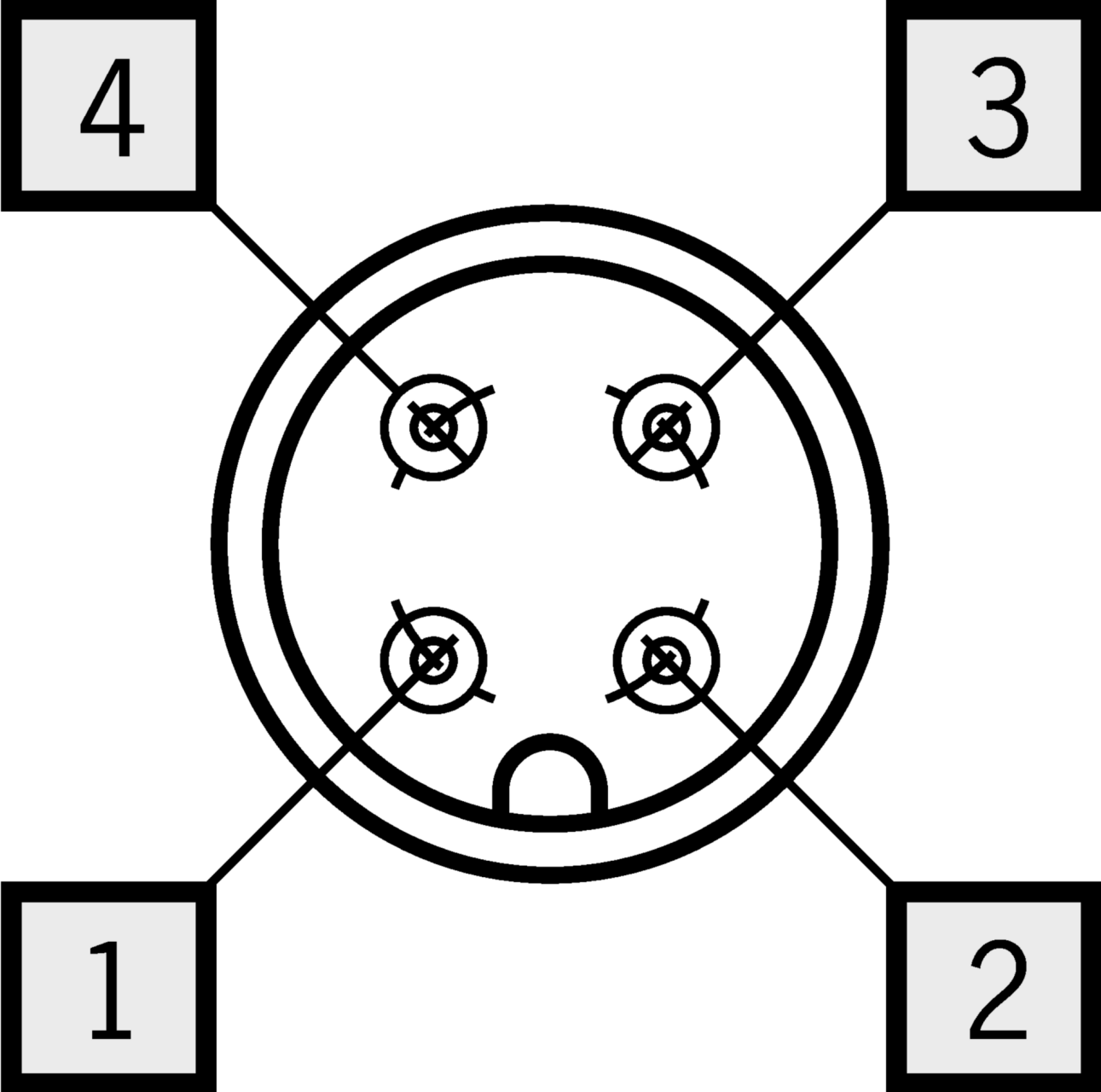

Connection examples

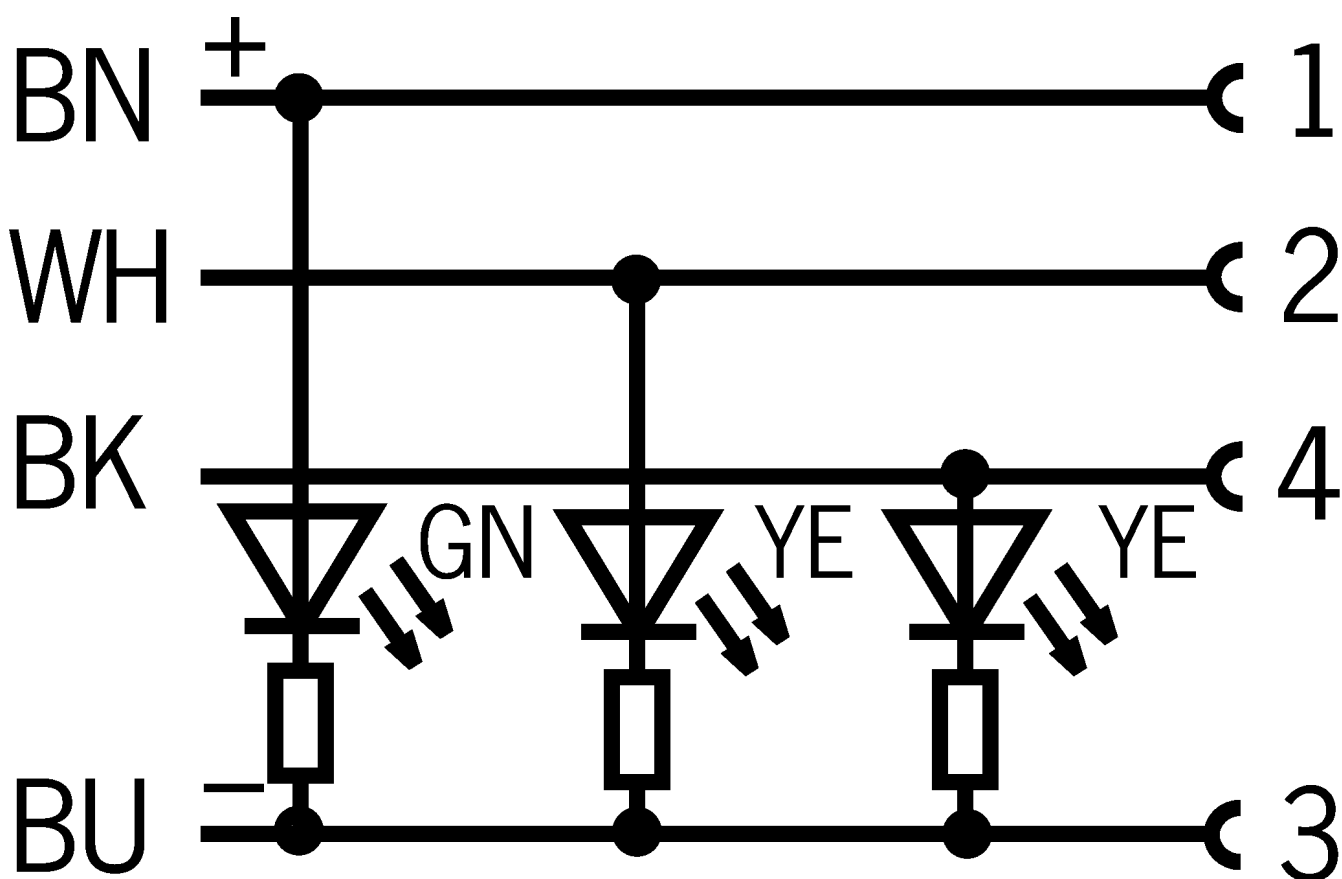

Connection examples

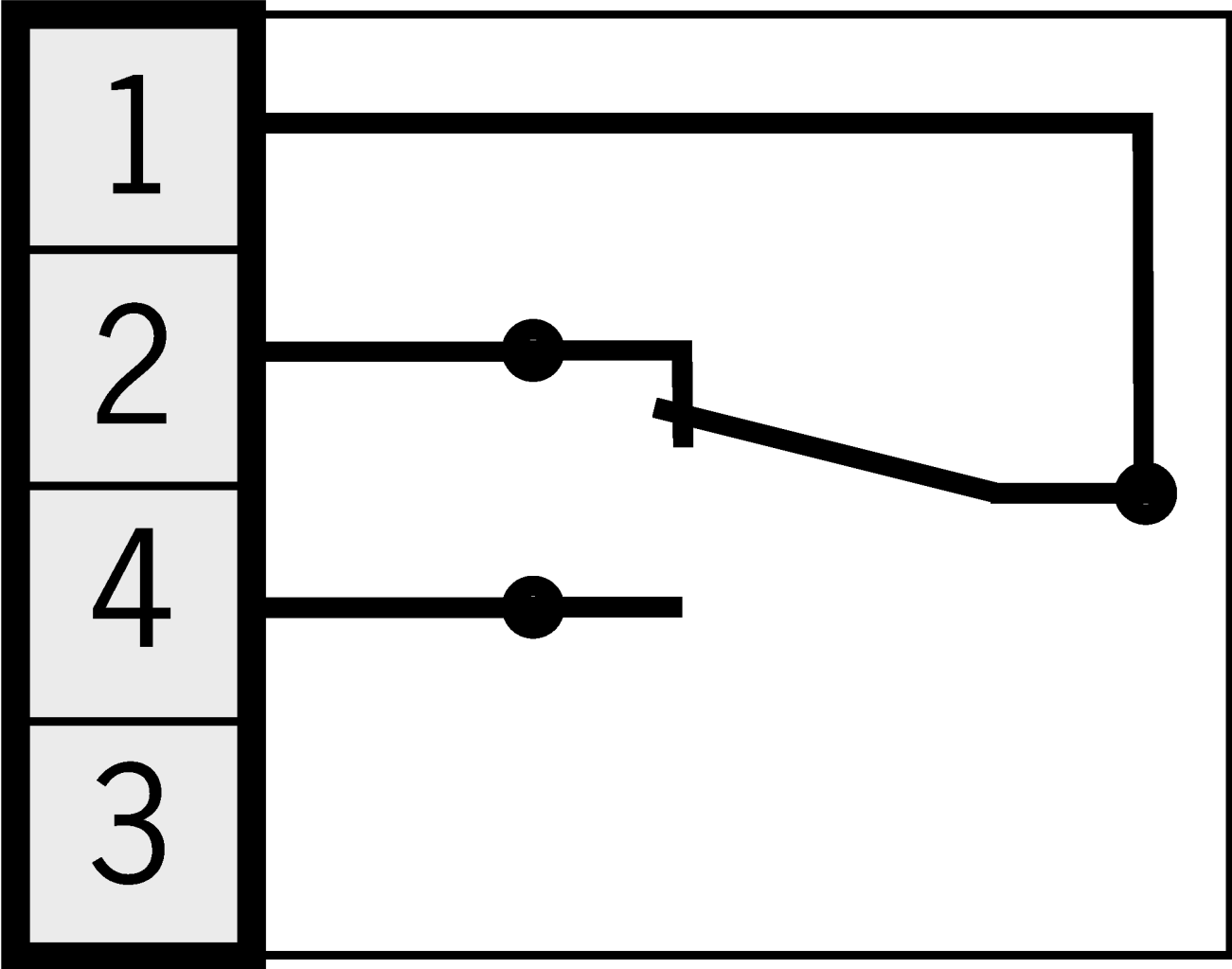

Technical data

Approvals



Electrical connection values

Fuse	max. 4 A gG
Rated insulation voltage U_i	50 V
Rated impulse voltage U_{imp}	2 kV
Utilization category	DC-13 2 A 24 V
Switching current	
min. at DC 24V	10 mA
thermal rated current I_{th}	4 A

Mechanical values and environment

Anfahrgeschwindigkeit	0.01 ... 50 m/min
Connection type	1 x Plug connector M12 (4-pin)
Number of door position NC contacts	1 Changeover contact
Number of door position NO contacts	1 (Changeover contact)
Actuating element	Slide bearing metal Roller plunger (d roller = 5 mm)
Actuating force	15 ... 20 N
Installation orientation	any
Storage temperature	-25 ... 80 °C
Mechanical life	10 x 10 ⁶
Switching principle	Changeover contact with snap-action function
Degree of protection	IP67

Ambient temperature -5 ... 80 °C

Material

Housing Anodized die-cast alloy

Contact Silver alloy, gold flashed

Miscellaneous

C number

C1526

Downloads

All documentation for this material can be found on our website:

<https://www.euchner.de/en-us/a/091001/?#downloads-tab>

Ordering data

Ordernumber	091001
Item designation	N01R550-MC1526
Gross weight	0,094kg
Customs tariff number	85365019000
ECLASS	27-27-06-01 Position switch (Type 1)