



Tablet Mount Safety Device HT3P



Safety Commander™

Enable industrial tablets to provide operation safety



IDEC CORPORATION

Tablet use on the production floor is on the rise, and safety is an issue

Tablets are more often used as control terminals at manufacturing sites. From the standpoint of ISO/IEC safety standards, when tablets or other operation devices are used near sources of danger from machinery, the tablets need to be equipped with safety devices, such as an enabling switch and an emergency stop switch for immediately shutting down the machinery.



Safety device easily attaches to tablet

With Safety Commander™, a tablet can be readily equipped with a safety device



Improves safety and operability

With Safety Commander™, tablets now come with safety. Operability is also improved by the ergonomic design. Furthermore, lower equipment cost and higher work efficiency can be achieved.

Adapts to both vertical and horizontal use

With Safety Command™, a tablet can be used in both vertical and horizontal orientation, thanks to a rotating holder. The emergency stop switch, which must be accessed instantly, can also be positioned for ease of use.

Vertical right-hand and left-hand use



Horizontal left-hand use



Horizontal right-hand use



Operability regardless of handedness

The ergonomic holder design and enabling switch position result in ease of holding and operability.

Held with left hand



Held with right hand





Tablet size: 8 to 11 inches

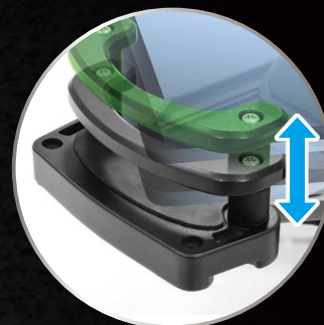

Thickness: up to 24mm (*1)

Fit tablets of various sizes

The adjustable docking structure fits screen sizes of 8 to 11 inches. Safety Commander™ can also be attached to rugged tablets with thicknesses of 10 to 24mm (*1) by using a spacer accessory.

*1) Standard thickness: up to 10mm
 When accessory "tablet thickness adjustment kit A" is used: up to 18mm
 When accessory "tablet thickness adjustment kit B" is used: up to 24mm

Emergency stop switch with LED indicator

Equipped with a safety lock mechanism, safe break action structure, and direct opening action. LED indicators enable the connection status of the e-stop switches to be visually recognized.

NEW

Newly available with an emergency stop switch

(button color: white, illuminated color: red) compliant with ISO 13850:2015)

In addition to IDEC's unique features, such as "Safety lock mechanism" and "Reverse energy structure", the illuminated E-stop switch allows intuitive visibility of the active/inactive status.



Inactive (Non-illuminated)



Active (Illuminated)

Three-position enabling switch

Safety during work operations is assured by the ergonomically designed three-position action (OFF→ON→OFF) for avoiding danger.



Rugged construction with drop resistance of 1.2 meters

Designed for assurance, the product has passed drop tests assuming accidental drop or impact while carrying. (*1)

*1) Drop resistance has been tested for tablet weights up to 1.1 kilogram. Note: Drop protection of the product or tablet is not guaranteed.



IP54 protection

Usable even in dusty environments or when exposed to splashing or spraying.



USB charging port

For charging the tablet, with no worries about losing battery power during use.

* 5V DC-1.5A output

USB port: Type-C

Key locking function

Locks down the telescope brackets.



- Photo shows the product mounted on a commercially-available tablet.
- The tablet is not included with this product and must be prepared separately by the customer.

Combining Safety Commander™ with a tablet solves common problems on the work floor

Can the need for dedicated terminal development be eliminated?

BEFORE

Creating dedicated terminal devices in house can be costly, including the development costs. Keeping up with changing needs as features are removed or upgraded is also a burden.



AFTER

Combining Safety Commander™ with a tablet results in a low-cost dedicated control terminal. **Hardware development is unnecessary**, and discontinuations or upgrades can be **handled readily at the software level**. Safety and security are also maintained.



Is there a way to improve touch panel functions?

BEFORE

A dedicated touch panel is used for equipment control. We would like to increase the functions but also want to keep costs down.

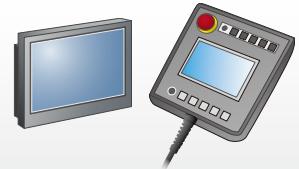

AFTER

Combining Safety Commander™ with a tablet enables use for process control, viewing of drawings, and operation log checking. Along with **safety assurance**, **on-site work efficiency is improved**. **Costs have also been kept low**.



Can the number of different touch panels on panel boards be reduced?

BEFORE

Individual touch panels are installed on multiple panel boards, but this is inefficient as the panels are used infrequently.

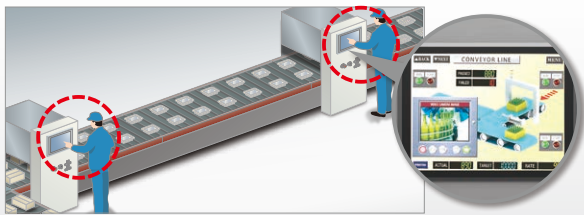

AFTER

Using one detachable **Safety Commander™** and tablet, operations can be performed in **multiple workplaces**. It is no longer necessary to install permanent touch panels in each workplace. **Safety is also improved**, since the safety features are right at hand.

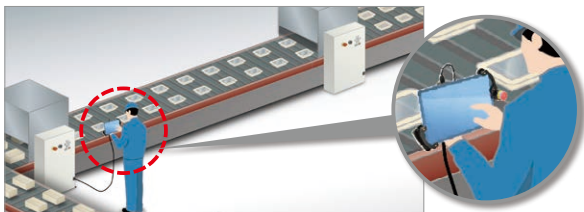

Can an existing tablet be used for equipment control?

BEFORE

We already have a tablet for process control and would like to use it also for controlling equipment, but are concerned about safety.



AFTER

By simply attaching safety features onto the tablet, we were able to use it for **equipment control**. We also **saved on equipment costs**.



Application examples



Robot teaching

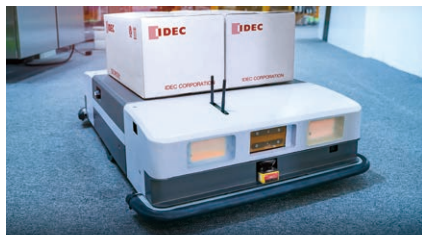

Manual control of AGVs and AMRs



Control of automobile production lines and conveyor lines



Add safety to tablets used on the factory floor

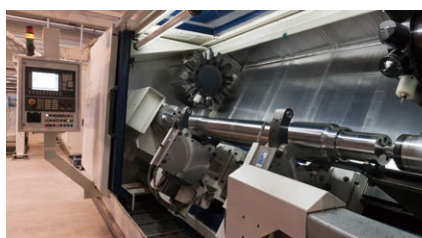

Control of large equipment or equipment operations



Control of semiconductor manufacturing equipment, and chip placement machines.



Maintain automated car parking systems



Utilize Web browser functions on PLCs



Safer use of industrial tablets

The story of Safety Commander™ development

For more than 20 years, IDEC has been engaged in development of devices that merge SUI (*1) and GUI (*2). As tablets have come into wide use, we developed the Safety Commander™, aiming to add easy-to-use touch panels and reliable switches while maintaining high ergonomics and ruggedness.

*1) SUI (Solid User Interface)
Human/machine interface based on operation of physical switches, buttons and other such parts.

*2) GUI (Graphical User Interface)
Human/machine interface based on operation of virtual parts displayed on a screen, such as figures and icons.

1997 ~

2003 ~

2019

2021

Development of control & teaching pendants that combine the operating/display devices of each era with the concept of merging SUI and GUI



HG2R / S

Large LCD touch panel. Equipped with "CC click" providing operating feedback



HG1T



HG1H



HG1U

Small LCD + mechanical switches. Membrane and mechanical switches became mainstream



HG1P

High-resolution touch panel + mechanical switches



HT3P

Tablet + mechanical switches
Merged tablet with emergency stop switch/enabling switch

HT3P Safety Commander™

Enhance safety and usability

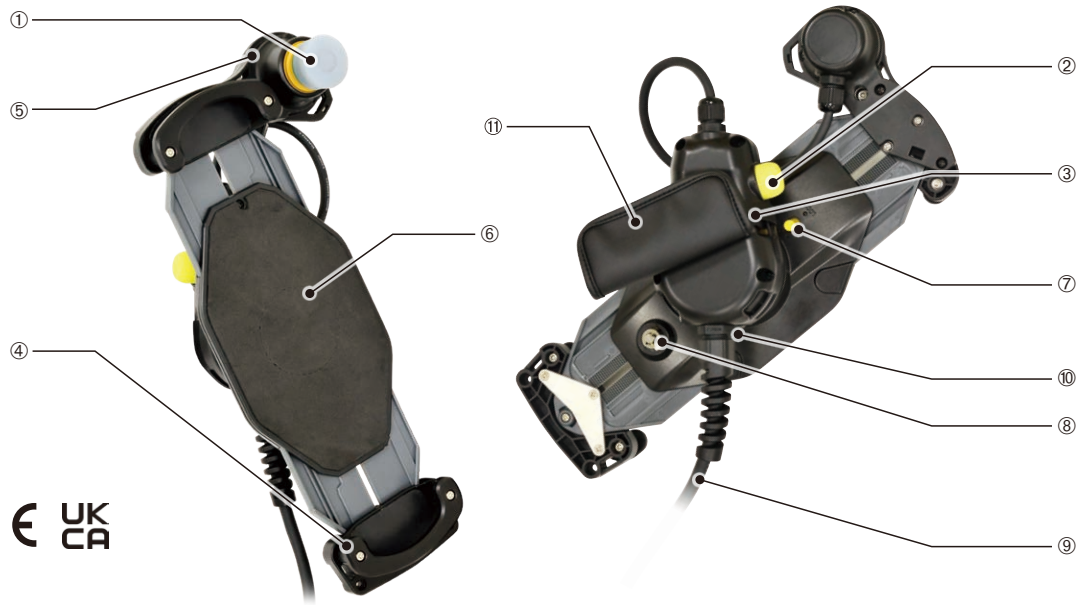

No.	Name	Details
1	Emergency stop switch	XA1E-LV3SG02Q4WR (IDEC)
2	Enabling switch	HE5B-M2PY (IDEC)
3	Hand grip	Grip of the product
4	Hook	Tablet holding part
5	Emergency stop switch unit	Tablet holding part
6	Support pad	Tablet holding part
7	Extendable lock lever	Extendable lever for tablet holder
8	Extendable lock key	Key lock for extendable lever
9	Cable	5m wire
10	USB interface	USB charging port USB port: Type-C
11	Hand strap	Accessory

HT3P

Main unit

Quantity: 1





Name	Table size	Part no. (Ordering no.)	Switch	
			Emergency stop switch	Enabling switch
Safety Commander™ Illuminated E-stop switch model (button: white, illumination color: red)	8 to 11 inches	HT3P-SLNP-5M-W	XA1E-LV3SG02Q4WR (Button: white, illumination color: red)	HE5B-M2PY

Maintenance Parts

Name	Shape	Specification	Part no. (Ordering no.)	Quantity	Remarks
Hand strap		Artificial leather	HT9Z-3PS1	1	Back hand hold type
Extendable lock release key		Metal	HT9Z-3PK01	2	-
Sponge sheet for thickness adjustment		EVA foam Height: 4mm	HT9Z-3PHA04	1	Used when there is a gap between the tablet and tablet holder
Hook		Frame: Plastic Spacer: Aluminum Rubber tube: Rubber	HT9Z-3PHZ	1	Hook to hold the tablet

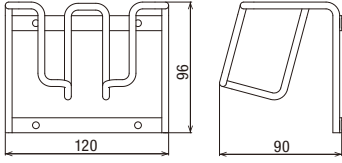
Accessories

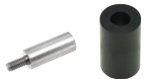
Dimensions in mm.

Name	Shape	Material	Part no. (Ordering no.)	Quantity	Remarks
Wall mount bracket		Stainless steel	HT9Z-3PF1	1	For mounting on walls The mounting centers of the screws comply with VESA standards 
Tablet thickness adjustment kit A		Spacer: Aluminum Rubber tube: Rubber	HT9Z-3PHB08	Spacer: 4 Rubber tube: 4	For tablets with 11 to 18mm thickness tablets
Tablet thickness adjustment kit B		Spacer: Aluminum Rubber tube: Rubber	HT9Z-3PHB14	Spacer: 4 Rubber tube: 4	For tablets with 19 to 24mm thickness
Neck strap		Artificial leather	HT9Z-3PS2	1	To wear around the neck. For safety, the strap will loosen when a certain amount of load is applied.

General Specifications

Environmental specifications	Operating temperature	-20 to +55°C (USB power supplied while holding the grip: -20 to +35°C)
	Operating temperature	-20 to +55°C
	Operating humidity	45 to 85%RH (without condensation)
	Storage humidity	45 to 85%RH (without condensation)
	Pollution degree	3
Electrical specifications (*2)	Rated input voltage	XA1E illuminated part: 24V DC±10% USB power input: 24V DC -15%/+20% (*1)
	Rated input voltage	60V
	Contact rating (*3)	XA1E-LV3SG02Q4WR (Button: white, illumination color: red)
		2A/30V DC (resistive load) 1A/30V DC (inductive load)
		HE5B-M2PY
		1A/30V DC (resistive load) 0.7A/30V DC (inductive load)
EMC	Immunity Zone	Zone A
Mechanical specification	Vibration	5 to 8.4Hz: amplitude: 3.5mm 8.4 to 150Hz acceleration: 9.8m/s ² (2 hours on each of 3 directions)
	Shock	147m/s ² , 11ms (5 times on each of 6 directions)
Construction Specifications	Degree of protection	IP54 (*4)
	Table size	Tablet diagonal length: 234 to 300mm (when expanded: up to 320mm) Screen size : 8 to 11 inch
	Compatible tablet thickness (*5)	Standard thickness: up to 10mm (*6)
	Weight (approx.) (*7)	530g (Approx.) (Excluding Cable) 980g (Approx.) (Including Cable)
	Tablet holder rotation angle	200° Approx.
	Housing	Black
USB specifications	Interface	USB Type-C connector Power supply only: 5V DC-1.5A output
Applicable standards		IEC/EN 60947-5-1 IEC/EN 60947-5-5 (XA1E-LV3SG02Q4WR) IEC/EN 60947-5-8 (HE5B-M2PY) UL 508 UL 60947-1 UL 60947-5-1 UL 60947-5-5
	Safety standards	IEC/EN 61010-1 IEC/EN 61010-2-201
	Applicable standards for use	ISO 12100 IEC/EN 60204-1 ISO 10218-1 ISO 10218-2
	EMC standards	IEC/EN 61131-2
Certification standard		UL508 UL60947-5-5

*1) If there is a risk of malfunction or destruction to the USB power supply or tablet due to noise from the connected power supply, use a dedicated USB power supply power supply that is independent of other power supplies.

*2) Safety approval ratings

UL certification Overall Device: Rated Class 2
Switch Contact: 30V DC/0.7A Resistive
Illumination for Switch: 24V DC/11mA
USB Power Supply Input: 24V DC/0.5A
USB Power Output: 5V DC/1.5A
Maximum ambient temperature: 40°C
Environmental rating: Type 1
Certified with a maximum tablet weight of 1.1 kg

*3) Product specifications of consisting items

*4) Except when connecting a USB cable.

*5) Some tablets may not apply depending on the shape.

*6) If the tablet does not have enough thickness, use a sponge sheet for adjusting the thickness.

When the tablet thickness is 11 to 18mm, use HT9Z-3PHB08, when the thickness is 19 to 24mm, use HT9Z-3PHB14 as additional parts.

*7) Excluding hand strap and other accessories.

Dimensions

Dimensions in mm

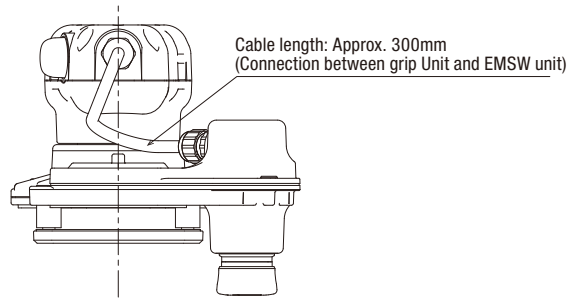

Tablet holder unit
Maximum expansion

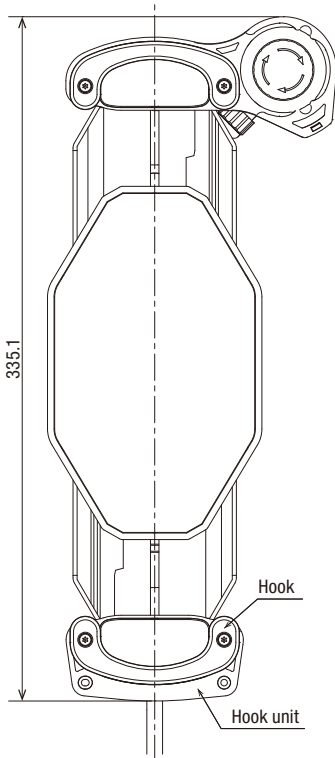

Tablet holder unit
Minimum expansion

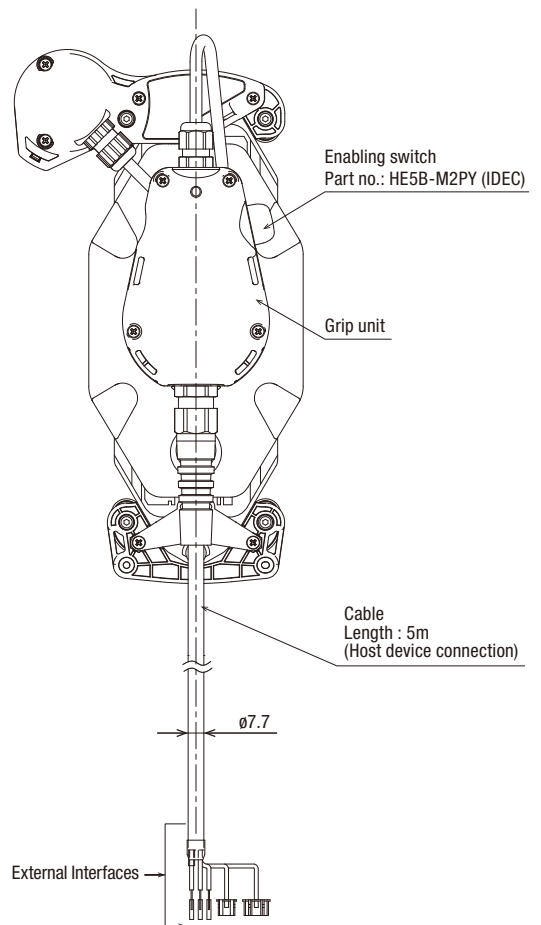
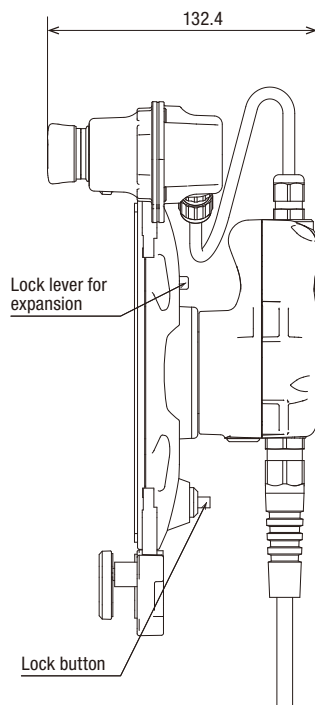
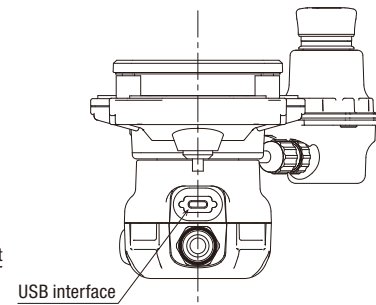
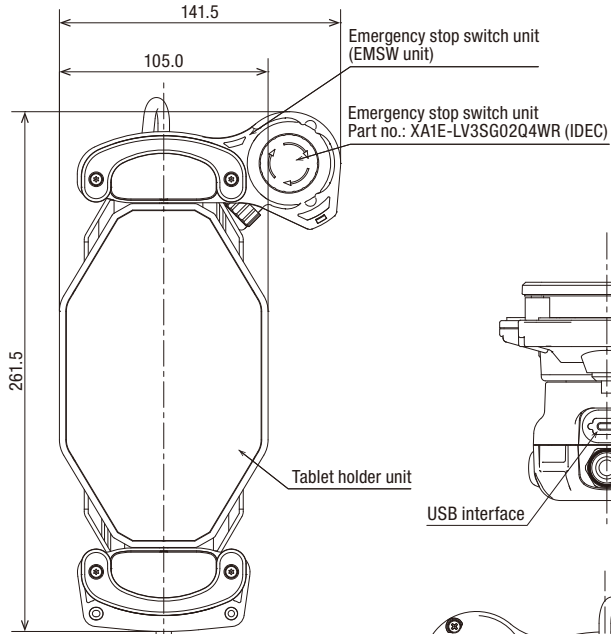

External Interface

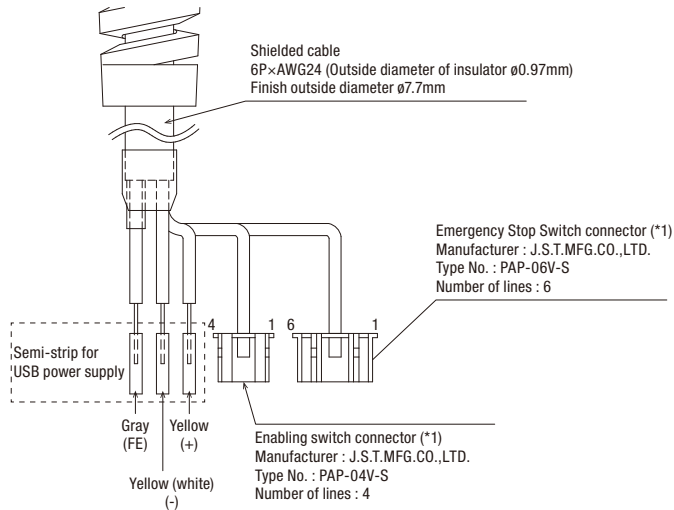

*1) Disconnect the connector if it is not necessary.

When mounting the connector to the end of the cable, select the connector depending on the specifications of the cable and the operating environment.

Recommended connector: CA-12PIN128007-1619709 (PHOENIX CONTACT)

The connector part is not UL approved.

	Connector terminal no.	Wire color	Function name
Emergency stop switch	1	Red	LED lamp (24V DC)
	2	Black	LED lamp (0V DC)
	3	Green	Contact 1 (NC)
	4	Green (white)	Contact 1 (NC)
	5	Red (white)	Contact 2 (NC)
	6	Black (white)	Contact 2 (NC)
Enabling switch	1	Brown	Contact 1 (NC)
	2	Brown (white)	Contact 1 (NC)
	3	Blue	Contact 2 (NC)
	4	Blue (white)	Contact 2 (NC)
USB power supply	-	Yellow	+ (24V DC)
		Yellow (white)	- (0V)
		Gray	FE

System Configuration

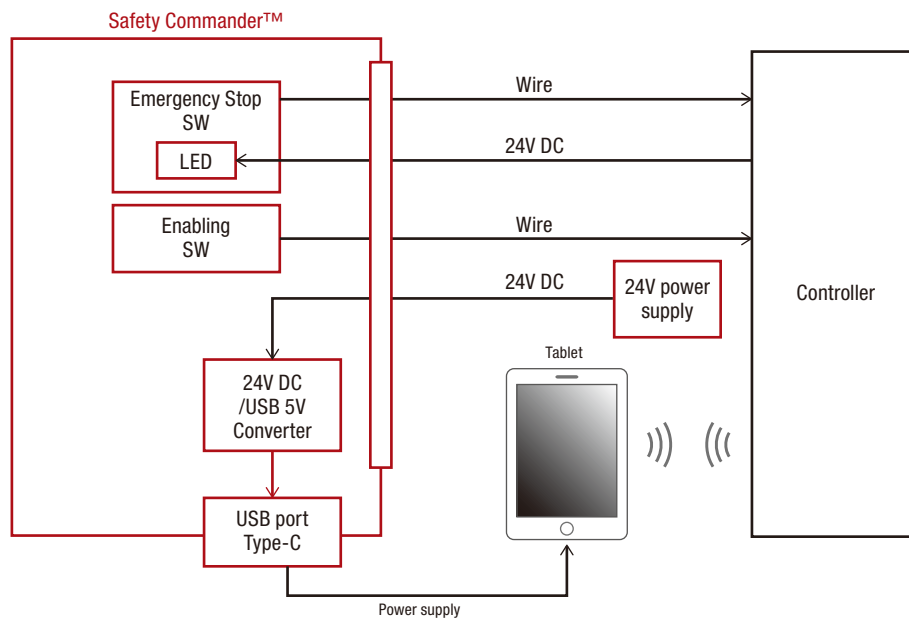

Tablet holder unit rotating mechanism

- Tablet base installing position

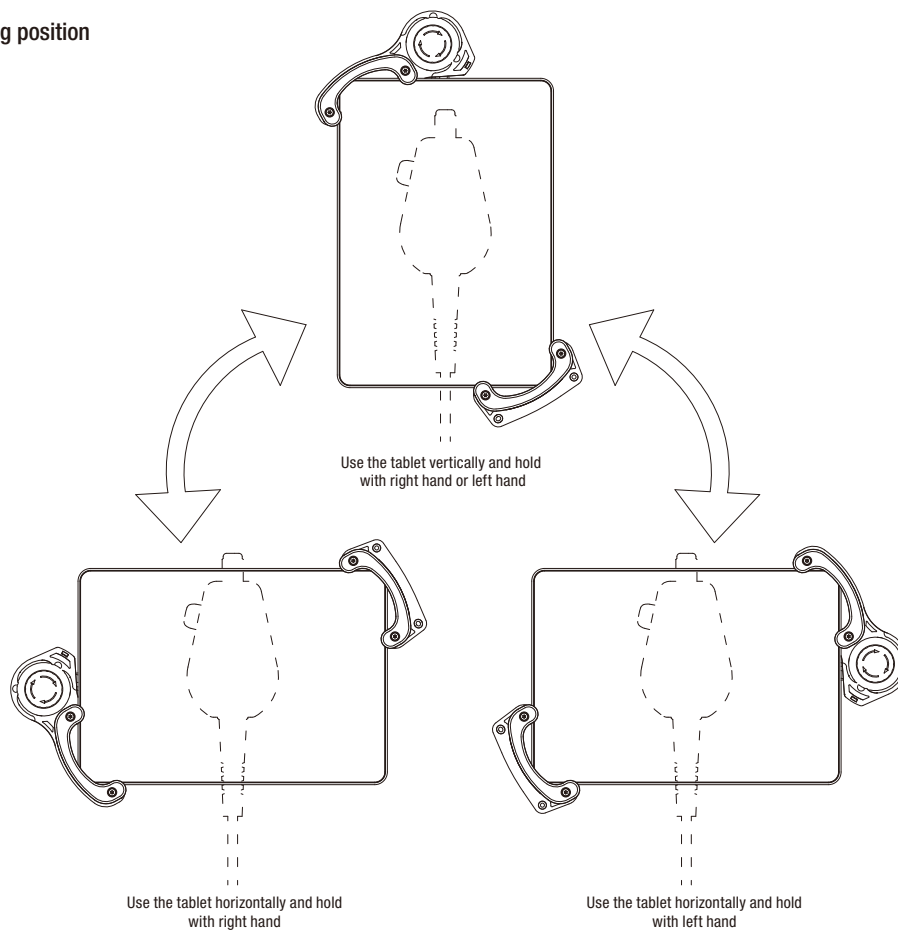

- Rotatable angle of the tablet holder unit relative to the grip unit (*1)

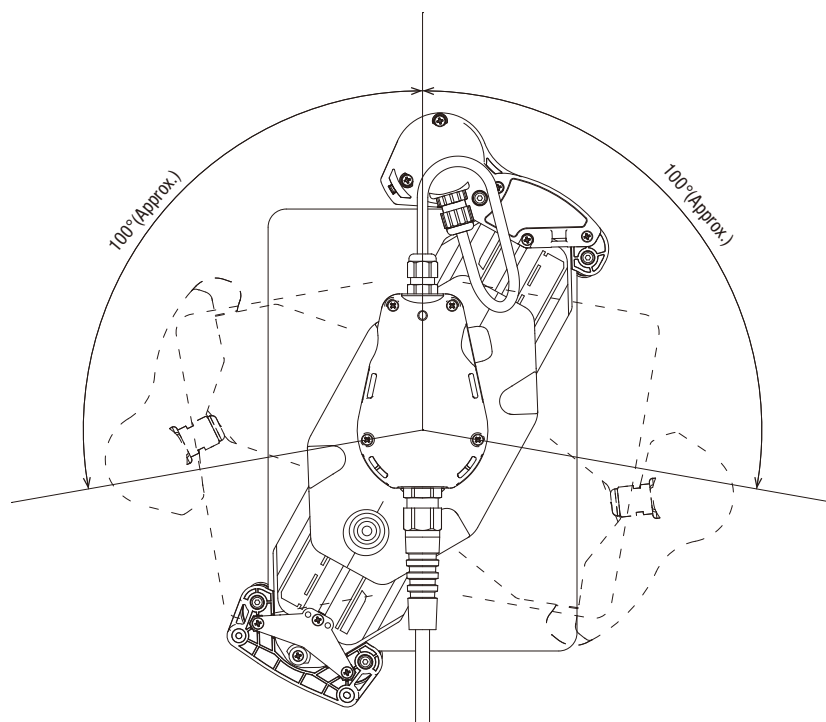

*1) Do not force the tablet holder to rotate. Otherwise, damage may occur..

⚠ Safety Precautions

Turn off the power before installation, removal, wiring, maintenance, and inspection. Failure to turn power off may cause electrical shock or fire hazard.

Instructions

Be sure to read the instruction sheet before installation, wiring, operation, and maintenance of the product.

For details on installation, wiring, and maintenance, see the Instruction sheet and User's Manual from the URL below.
URL: <https://product.idec.com/?product=HT3P>



- When using the HT3P in applications which require high level of safety, add a fail-safe or backup functionality, and verify an adequate level of safety using the product specifications.
- Turn off the power to the HT3P before installation, removal, wiring, maintenance, and inspection of HT3P. Failure to turn power off may cause electrical shock or fire hazard.
- Special expertise is required to install and wire the HT3P. Users without such expertise must not perform installation or wiring.
- Take appropriate safety measures according to the safety requirements of the machine or system used and the results of the risk assessment. The control system for the emergency stop function and the enabling function should be configured the circuit to satisfy the required performance level (PLr) / control category / Safety Integrity Level (SIL) required by the requirements of the application standard and the risk assessment result. The emergency stop pushbutton switch mounted on the HT3P should be configured the circuit according to the stop category 0 or 1 based on the applicable standard IEC60204-1.
- If the HT3P and the machine are removable, be sure to install one or more emergency stop devices on the machine. If you remove HT3P, store it properly so that the user does not accidentally operate the disabled emergency stop pushbutton switch.
- Do not, under any circumstances, hold the enabling switch on the HT3P in position 2 with tape, string, or deform the rubber cover. The intrinsic function of the enabling switch will be lost, and the enabling switch may not work in case of an emergency situation.
- When using the HT3P, place your finger firmly on the enabling switch.
- Perform regular checks to confirm that the emergency stop switch and enabling switch work properly. It is extremely dangerous if the enabling switch no longer returns to position 1 due to a foreign object becoming lodged in the switch because position 2 will be maintained even when you remove your hand.
- Stop using the HT3P if it is accidentally dropped or exposed to significant shocks, check for damage, and confirm that its various functions work safely and correctly.
- Malfunction may result due to noise. Follow the instructions below
 - Set the FE terminals to class D grounding (Class 3 grounding : Grounding resistance: 100Ω or less).
 - Do not connect the grounding conductor to the grounding conductor of the power unit.
- Do not supply power to the USB with foreign matter or water on the product.
- Do not pull or apply load to the cable, USB cable, or the connector. Otherwise, fire or malfunction may occur.
- Use a dedicated optional neck strap. Be careful not to get neck straps getting caught in machines during operation.
- If a plug or connector is attached to the cable of the product so that it can be connected or disconnected, at least one permanently fixed emergency stop device must be installed on the machine. Furthermore, if the product is removed, it must be stored out of sight or otherwise managed in an appropriate storage location to prevent operators from mistakenly operating an inactive emergency stop pushbutton switch as if it is active.
- HT3P is designed for indoor use only (Not for outdoor use)
- Use of the product in high temperature or high-humidity environments, or in locations where it is exposed to condensation, corrosive gas or large shock loads, can create the risk of electric shock or fire.
- Be sure to prevent metal fragments or wire chips from dropping inside the HT3P housing. Ingress of such fragments and chips may cause fire hazard, damage, and malfunction.
- Use a power supply of the rated value. Using a wrong power supply or wiring in reverse polarity may cause fire hazard and damage.
- Install according to the instructions. Improper installation may result in, failure, electrical shock, fire hazard, or malfunction.
- Use the HT3P only for its intended purpose. Otherwise functions of the product may be impaired.
- Please note that some tablets may interfere with power or volume buttons at installation.
- Use within the range of use of the tablet and HT3P.
- Make sure of safety before starting and stopping HT3P. Incorrect operation of HT3P may cause mechanical damage or accidents.
- Do not attempt to disassemble, repair or modify HT3P. This can create the risk of fire or electrical shock.

3-position operation of enabling switch

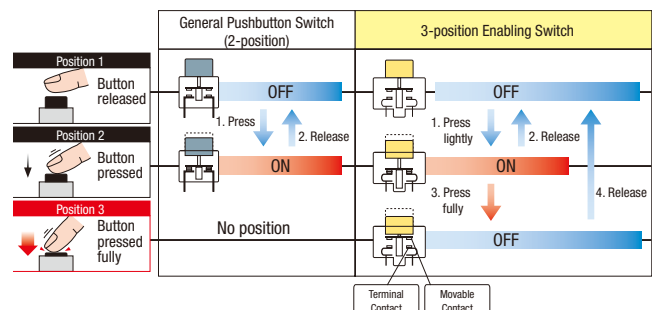

Ordering Terms and Conditions

Thank you for using IDEC Products.

By purchasing products listed in our catalogs, datasheets, and the like (hereinafter referred to as "Catalogs") you agree to be bound by these terms and conditions. Please read and agree to the terms and conditions before placing your order.

1. Notes on contents of Catalogs

- (1) Rated values, performance values, and specification values of IDEC products listed in this Catalog are values acquired under respective conditions in independent testing, and do not guarantee values gained in combined conditions.
Also, durability varies depending on the usage environment and usage conditions.
- (2) Reference data and reference values listed in Catalogs are for reference purposes only, and do not guarantee that the product will always operate appropriately in that range.
- (3) The specifications / appearance and accessories of IDEC products listed in Catalogs are subject to change or termination of sales without notice, for improvement or other reasons.
- (4) The content of Catalogs is subject to change without notice.

2. Note on applications

- (1) If using IDEC products in combination with other products, confirm the applicable laws / regulations and standards.
Also, confirm that IDEC products are compatible with your systems, machines, devices, and the like by using under the actual conditions. IDEC shall bear no liability whatsoever regarding the compatibility with IDEC products.
- (2) The usage examples and application examples listed in Catalogs are for reference purposes only. Therefore, when introducing a product, confirm the performance and safety of the instruments, devices, and the like before use. Furthermore, regarding these examples, IDEC does not grant license to use IDEC products to you, and IDEC offers no warranties regarding the ownership of intellectual property rights or non-infringement upon the intellectual property rights of third parties.
- (3) When using IDEC products, be cautious when implementing the following.
 - i. Use of IDEC products with sufficient allowance for rating and performance
 - ii. Safety design, including redundant design and malfunction prevention design that prevents other danger and damage even in the event that an IDEC product fails
 - iii. Wiring and installation that ensures the IDEC product used in your system, machine, device, or the like can perform and function according to its specifications
- (4) Continuing to use an IDEC product even after the performance has deteriorated can result in abnormal heat, smoke, fires, and the like due to insulation deterioration or the like. Perform periodic maintenance for IDEC products and the systems, machines, devices, and the like in which they are used.
- (5) IDEC products are developed and manufactured as general-purpose products for general industrial products. They are not intended for use in the following applications, and in the event that you use an IDEC product for these applications, unless otherwise agreed upon between you and IDEC, IDEC shall provide no guarantees whatsoever regarding IDEC products.
 - i. Use in applications that require a high degree of safety, including nuclear power control equipment, transportation equipment (railroads / airplanes / ships / vehicles / vehicle instruments, etc.), equipment for use in outer space, elevating equipment, medical instruments, safety devices, or any other equipment, instruments, or the like that could endanger life or human health
 - ii. Use in applications that require a high degree of reliability, such as provision systems for gas / waterworks / electricity, etc., systems that operate continuously for 24 hours, and settlement systems
 - iii. Use in applications where the product may be handled or used deviating from the specifications or conditions / environment listed in the Catalogs, such as equipment used outdoors or applications in environments subject to chemical pollution or electromagnetic interference
If you would like to use IDEC products in the above applications, be sure to consult with an IDEC sales representative.

3. Inspections

We ask that you implement inspections for IDEC products you purchase without delay, as well as thoroughly keep in mind management/maintenance regarding handling of the product before and during the inspection.

4. Warranty

(1) Warranty period

The warranty period for IDEC products shall be one (1) year after purchase or delivery to the specified location. However, this shall not apply in cases where there is a different specification in the Catalogs or there is another agreement in place between you and IDEC.

(2) Warranty scope

Should a failure occur in an IDEC product during the above warranty period for reasons attributable to IDEC, then IDEC shall replace or repair that product, free of charge, at the purchase location / delivery location of the product, or an IDEC service base. However, failures caused by the following reasons shall be deemed outside the scope of this warranty.

- i. The product was handled or used deviating from the conditions / environment listed in the Catalogs
- ii. The failure was caused by reasons other than an IDEC product
- iii. Modification or repair was performed by a party other than IDEC
- iv. The failure was caused by a software program of a party other than IDEC
- v. The product was used outside of its original purpose
- vi. Replacement of maintenance parts, installation of accessories, or the like was not performed properly in accordance with the user's manual and Catalogs
- vii. The failure could not have been predicted with the scientific and technical standards at the time when the product was shipped from IDEC
- viii. The failure was due to other causes not attributable to IDEC (including cases of force majeure such as natural disasters and other disasters)

Furthermore, the warranty described here refers to a warranty on the IDEC product as a unit, and damages induced by the failure of an IDEC product are excluded from this warranty.

5. Limitation of liability

The warranty listed in this Agreement is the full and complete warranty for IDEC products, and IDEC shall bear no liability whatsoever regarding special damages, indirect damages, incidental damages, or passive damages that occurred due to an IDEC product.

6. Service scope

The prices of IDEC products do not include the cost of services, such as dispatching technicians. Therefore, separate fees are required in the following cases.

- (1) Instructions for installation / adjustment and accompaniment at test operation (including creating application software and testing operation, etc.)
- (2) Maintenance inspections, adjustments, and repairs
- (3) Technical instructions and technical training
- (4) Product tests or inspections specified by you

The above content assumes transactions and usage within your region. Please consult with an IDEC sales representative regarding transactions and usage outside of your region. Also, IDEC provides no guarantees whatsoever regarding IDEC products sold outside your region.

IDEC CORPORATION

Head Office 6-64, Nishi-Miyahara-2-Chome, Yodogawa-ku, Osaka 532-0004, Japan

USA IDEC Corporation
EMEA APEM SAS

Singapore IDEC Izumi Asia Pte. Ltd.
Thailand IDEC Asia (Thailand) Co., Ltd.
India IDEC Controls India Private Ltd.

China IDEC (Shanghai) Corporation
IDEC Izumi (H.K.) Co., Ltd.
Taiwan IDEC Taiwan Corporation

Japan IDEC Corporation

 www.idec.com

Specifications and other descriptions in this brochure are subject to change without notice.
Information in this brochure is current as of November, 2024.
2024 IDEC Corporation, All Rights Reserved.

EP1746-7-EMEA

