

# Klemsan

## EMD2 Series User Manual



**Section 1 GENERAL INFORMATION**

1.General Information	.....	01-03
-----------------------	-------	-------

**Section 2 INSTALLATION**

2.1 Preparation for Installation	.....	04-05
2.2 Mounting	.....	05
2.3 Terminals and Wiring	.....	06-07
2.3.1 Products with Direct Connection	.....	08
2.3.2 Product with Current Transformer Connection	.....	08
2.3.3 Common Connections	.....	08
2.4 Icons and LED Notifications	.....	09

**Section 3 MENU**

3.1 Measurement	.....	10-13
3.2 Settings	.....	14-18
3.3 Date&Time	.....	19
3.4 Info	.....	19
3.5 Login	.....	19

**Section 4 TARIFF CONFIGURATION**

4. Tariff Configuration	.....	20-22
-------------------------	-------	-------

**Section 5 RS485 COMMUNICATION**

5. RS485 Communication	.....	23-36
------------------------	-------	-------

**Section 6 TECHNICAL SPECIFICATIONS**

6.1 Technical Specifications	.....	37-38
6.2 Dimensions	.....	39

**EMD2 Series**

---

**SECTION 1**  
GENERAL  
INFORMATION

Klemsan EMD2 series devices are energy meters that measure and record the basic electrical parameters required for monitoring single-phase power lines.

The following parameters are optionally measured in the devices.

- Voltage
- Current
- Frequency
- Active power
- Reactive power
- Apparent power
- Power factor
- THDV
- THDI
- 4 quadrants energy



Cihaz Modeli	580-1M-V4CT	180-0M-V1CT	180-0W-01	580-1M-V3	180-0M-02	180-1M-V2
Sipariş Numarası	606370	606371	606372	606373	606374	606375
Montaj Tipi	Ray Monte	Ray Monte	Ray Monte	Ray Monte	Ray Monte	Ray Monte
Ekran Tipi	Custom LCD	Custom LCD	Custom LCD	Custom LCD	Custom LCD	Custom LCD
Ölçüm Kalitesi (IEC 62053-21)	Class 0.5	Class 1	Class 1	Class 0.5	Class 1	Class 1
Akım Ölçümü	CT Bağlantılı	CT Bağlantılı	80 A Direkt Bağlantı	80 A Direkt Bağlantı	80 A Direkt Bağlantı	80 A Direkt Bağlantı
Ölçülen Parametreler	Tüm Ölçümler*	Tüm Ölçümler*	Tüm Ölçümler*	Tüm Ölçümler*	Tüm Ölçümler*	Tüm Ölçümler*
Demand Ölçümleri	√	-	-	√	-	√
Tarife Sayısı	4	2	4	2	1	1
Pals çıkışı	-	2 (Ayarlanabilir)	1 (Sabit)	2 (Ayarlanabilir)	2 (Ayarlanabilir)	-
RS485 Haberleşmesi	√	-	-	√	-	√

All measurements\*: are measured with the parameters mentioned above.

In addition to the measurement features, the devices have the following functions depending on its model;

- Support for direct connections of up to 80 amps
- Import active, export active, import reactive, export reactive
- Calculates the demand values for current, active power, reactive power and apparent power and stores them in its memory
- Determines the maximum and minimum values of current, voltage, frequency, PF and power values and stores them in its memory
- 2 tariff options
- Unauthorized-access protection with user password
- Adjustable digital output for alarm and pulse output optionally
- LCD display (energy measurement, instant measurements and device information)
- Modbus RTU communication via RS485 interface
- Backlight on time setting

**EMD2 Series**

---

**SECTION 2**  
INSTALLATION

## 2.1 Preparation for Installation

- Assembly and related connections of the product must be implemented by authorized persons in accordance with the instructions of the user manual. The device should not be operated without making the correct connections.
- Before connecting the device to the mains, make sure that the power is cut off.
- Use a dry cloth to clean and dust the device. Do not use alcohol, thinner or any abrasive material.
- The device should only be commissioned after all connections have been made.
- Do not open or dismantle the cover of the device. There are no user-serviceable parts inside.
- The device should be kept away from humid, wet, vibrating and dusty environments.

! The manufacturer is not responsible for any undesirable situations that may arise as a result of not applying the above precautions.

## 2.2 Mounting

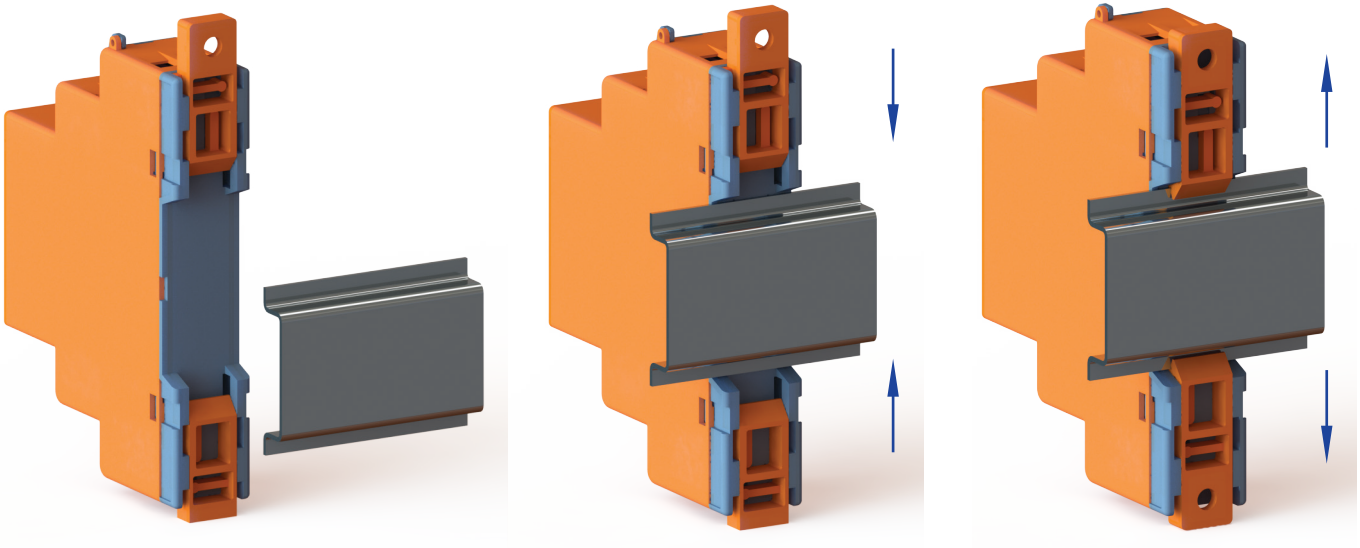

2.3 Terminals and Wiring

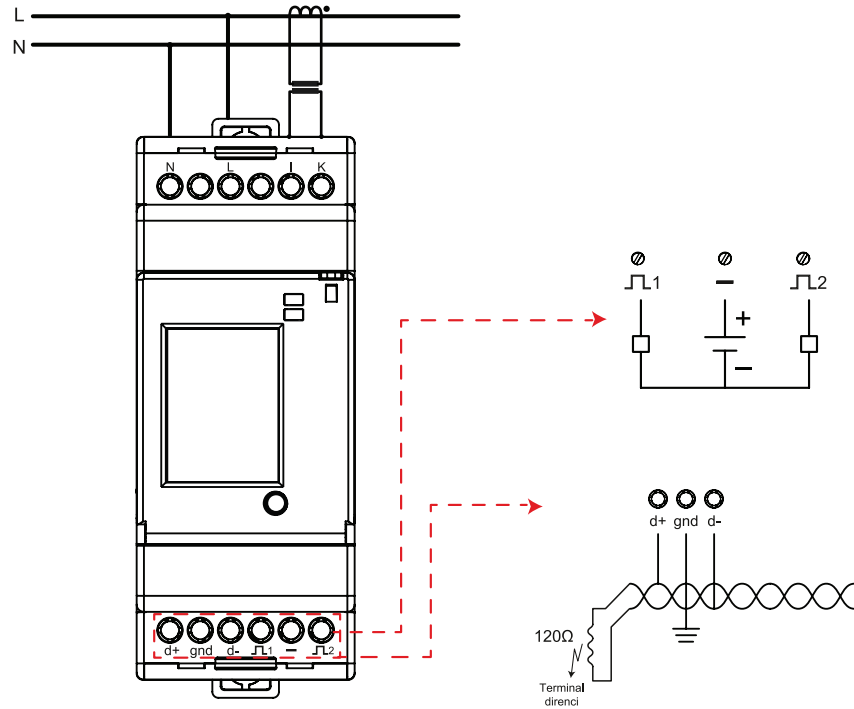

The connection diagram above is for devices with transformer connection.

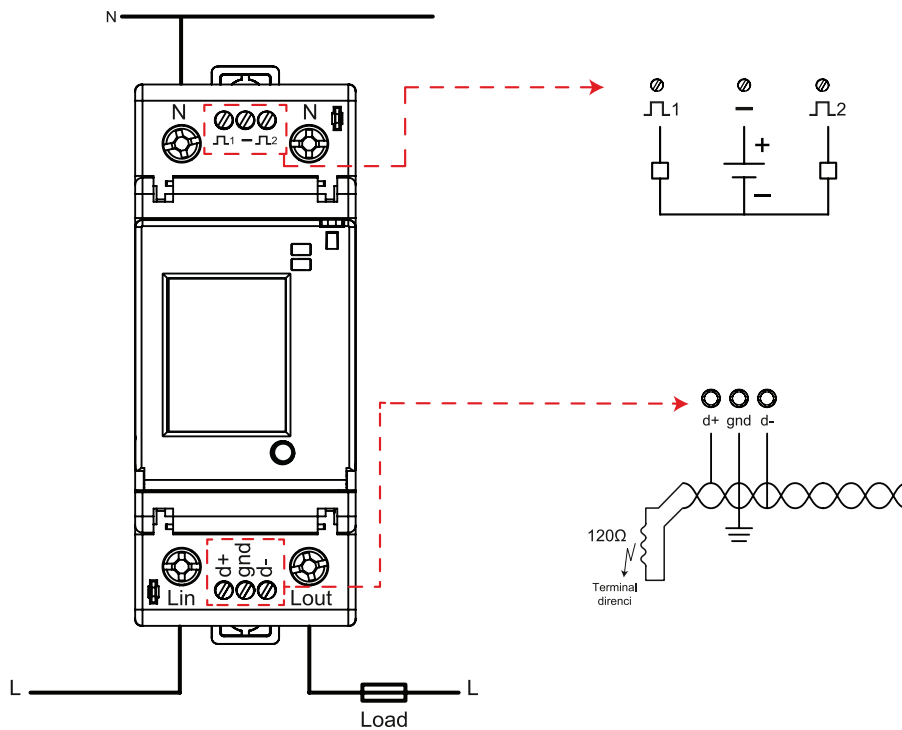

The connection diagram above is for devices with direct connection.

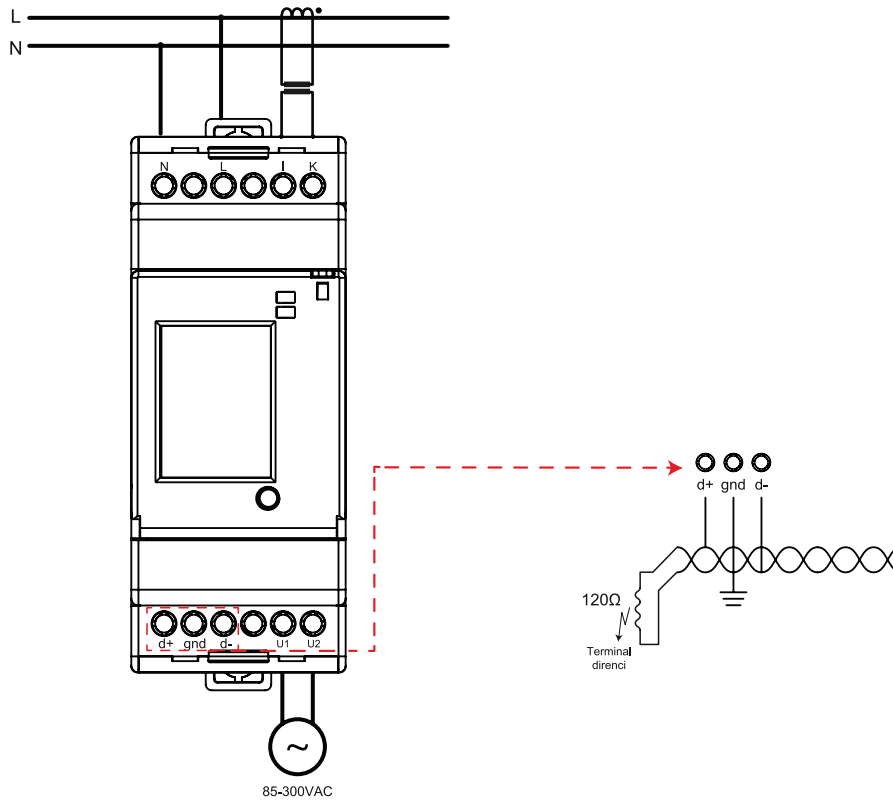

The connection diagram above is for devices with external power supply.

### 2.3.1 Products with Direct Connection

**Lin:** It is the terminal where the phase input of the device is connected.

**Lout:** Phase entering from “Lin” terminal exits from “Lout” terminal. From here it must be connected to the load.

**N:** It is the terminal where the neutral connection of the line is connected.

! The supply and measurement inputs of the device are common and are made through the “Lin” and “N” terminals. The supply voltage of the device is in the range of 85 ... 300 V AC.

### 2.3.2 Products with Transformer Connection

**La input:** Phase input of the AC voltage being measured.

**Lb output:** Neutral input of the AC voltage being measured.

**k:** Input connection of the AC current being measured.

**I:** Output connection of AC current being measured.

**U1 and U2:** Supply voltage (AC voltage) inputs of the device. (85-300V AC)

### 2.3.3 Common Connections

**Pulse1 Output “”:** It is the output terminal of the DC voltage applied to the “-” terminal when digital output 1. By default, the pulse 1 output gives 1000 impulses (1000 imp/kWh) for each measured kWh. Pulse duration is 100 ms.

**Pulse2 Output “”:** It is the output terminal of the DC voltage applied to the “-” terminal when digital output 2. By default, the pulse 2 output gives 1000 impulses (1000 imp/kWh) for each measured kWh. Pulse duration is 100 ms.

**com Input:** It is the terminal to which the positive end of the DC voltage to be digitally switched will be connected (common).

**d+:** It is the data+ input of the RS-485 interface.

**gnd:** It is the input where the ground connection of the RS-485 interface is made.

**d-:** It is the data- input of the RS-485 interface.

! The terminal descriptions are general and vary according to the models.

### 2.4 Icons and LED Notifications

The descriptions of the icons that appear on the device screen are shown below.

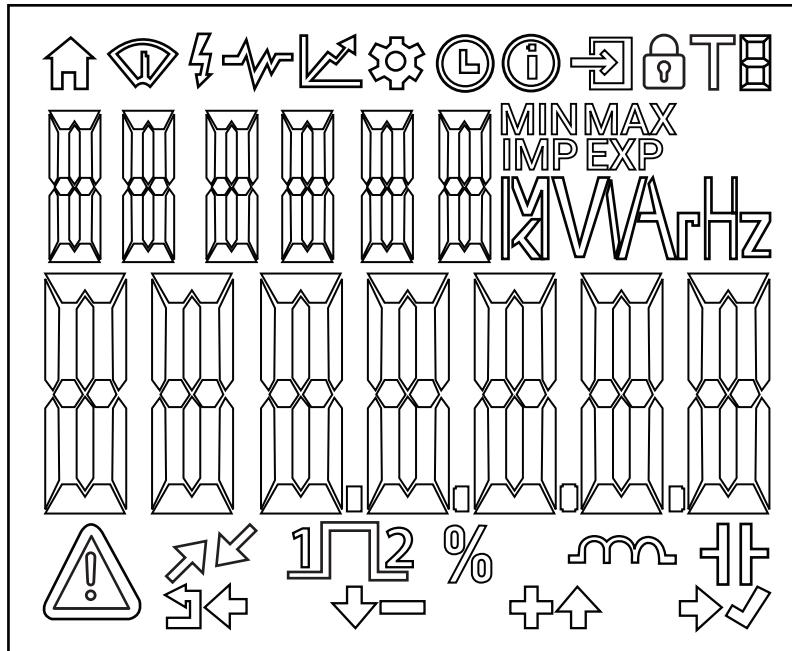

	Main Page Icon
	Measurement Page Icon
	Energy Page Icon
	Instant Values Page Icon
	Demand Page Icon
	Settings Page Icon
	Date-Time Page Icon
	Device Info Page Icon
	Input Page Icon
	Error and Warning Icon
	Communication Icons
	Pulse Icons
	Button Function Icons

**!** The icons on the screen are general and vary according to the devices.

**EMD2 Series**

---

**SECTION 3**  
**MENU**

There are 5 main menus on the device.



### 3.1 Measurement

The following data is displayed under the Measurement tab.

<b>MEASUREMENT (MEASURE)</b>	Import Active Energy	Total	Minimum	Voltage		
		T1		Current		
		T1-1		Export Active Power		
		T1-2		Import Active Power		
		T1-3		Export Reactive Power		
		T1-4		Import Reactive Power		
		T2		Apparent Power		
				Export PF		
	Export Active Energy	Total		Import PF	Maximum	Voltage
		T1		Frequency		Current
		T1-1		Export Active Power		
		T1-2		Import Active Power		
		T1-3		Export Reactive Power		
		T1-4		Import Reactive Power		
	T2	Apparent Power				
	Import Reactive Energy	Total	Export PF	Harmonic		THD
		T1	Voltage			Current
		T1-1	Demand			Current
		T1-2				Import Active Power
		T1-3				Export Active Power
		T1-4				Import Reactive Power
		T2				Export Reactive Power
		Apparent Power				
	Export Reactive Energy	Total	Max. Demand	Current		
		T1		Import Active Power		
		T1-1		Export Active Power		
		T1-2		Import Reactive Power		
		T1-3		Export Reactive Power		
		T1-4		Apparent Power		
		T2		Frequency		
		Runtime	Voltage			
	Current					
Active Power						
Reactive Power						
Apparent Power						
PF						
Frequency						

**Import Active Energy**

Under this tab, there is import active energy data measured in the device. According to the number of tariffs available in the device, the total and tariff values are displayed.

**Export Active Energy**

Under this tab there is the export active energy data measured in the device. According to the number of tariffs available in the device, the total and tariff values are displayed.

**Import Reactive Energy**

Under this tab, there is import reactive energy data measured in the device. According to the number of tariffs available in the device, the total and tariff values are displayed.

**Export Reactive Energy**

Under this tab is the export reactive energy data measured in the device. According to the number of tariffs available in the device, the total and tariff values are displayed.

**Runtime Values**

This tab shows the instant values of the following parameters.

- Voltage
- Current
- Active power
- Reactive power
- Apparent power
- Power Factor
- Frequency

**Minimum Values**

Under this tab, the minimum values of the following parameters are kept.

- Voltage
- Current
- Export Active Power
- Import Active Power
- Export Reactive Power
- Import Reactive Power
- Apparent Power
- Export PF
- Import PF
- Frequency

**Maximum Values**

Under this tab, the maximum values of the following parameters are kept.

- Voltage
- Current
- Export Active Power
- Import Active Power
- Export Reactive Power

- Import Reactive Power
- Apparent Power
- Export PF
- Import PF
- Frequency

#### Harmonic

The harmonic data is displayed under this tab. In addition to the total harmonic disturbances, odd harmonics up to 31 are also measured for current and voltage.

#### Demand

Under this tab, the current measured in the device, import active power, export active power, import reactive power, export reactive power and instantaneous demand values of apparent power are displayed.

NOT: 580-1M-V4CT ve 580-1M-V3 ürünleri demand tahmini yapılmaktadır. Demand tahmini, ayarlar kısmından yapılan demand hesaplama metoduna göre tahminleme yapmaktadır. Tahmini demand verileri sadece haberleşme üzerinden görüntülenmektedir.

- ! The products 580-1M-V4CT and 580-1M-V3 have demand estimation. They can make estimations according to the demand calculation method in the settings section. Estimated demand data is only displayed via communication.

#### Maximum Demand

The previous demand values of the current, import active power, export active power, import reactive power, export reactive power and apparent power are displayed in this tab.

- ! The menu features mentioned above are general and vary according to the device models.

## 3.2 Settings

SETTINGS	Serial Communication	Slave ID	1 .. 247
		Baudrate	1200 2400 4800 9600 19200 38400 57600 115200
		Parity	(None) (Odd) (Even)
		Stop Bit	1 2
		Data Type	Big Endian (BE) Little Endian (LE) Big Endian Byte Swap (BE SWAP) Little Endian Byte Swap (LE SWAP)
	Demand	Method	Slide Rolling Fixed
		Period	1 .. 60 mins
		Sub-interval	1 .. 60 mins
	Pulse 1	Source	Import Active Energy Export Active Energy Import Reactive Energy Export Reactive Energy Off
		Mode	Energy Alarm
		Energy	1 .. 9
		Multiplier	1 10 (MUL10) 100 (MUL100) 1000 (MUL1000) 1/1000 (DIV1000) 1/100 (DIV100) 1/10 (DIV10)
		Duration	30 .. 2500 msec
	Puls 2 (PALS 2)	Source	Import Active Energy Export Active Energy Import Reactive Energy Export Reactive Energy Off
		Mode	Energy Alarm
		Energy	1 .. 9
		Multiplier	1 10 (MUL10) 100 (MUL100) 1000 (MUL1000) 1/1000 (DIV1000) 1/100 (DIV100) 1/10 (DIV10)
		Duration	30 .. 2500 msec

SETTING (SET)	Device Settings	Language	Türkçe English
		Backlight	On Off Time Dependent
		Time	01 ... 60 sec
		Scroll	On Off
		Period	01 ... 60 sec
		Start Page	Voltage Current Active Power Reactive Power Apparent Power PF Frequency
	Date and Time	Year	00...99
		Month	1...12
		Day	1...31
		Hour	00...23
		Minute	00...59
		Second	00...59
	Network	CT Primary	5...9999
		CT Secondary	1 / 5
		VT Primary	100...1000000
		VT Secondary	100...500
		Ratio	With Without
		System Frequency	50 / 60 Hz
	Security	Protection	On Off
		Password	00000000...99999999
	Clear	Setting	
		Energy	
		Demand	
		Min&Max All	

! The tariff configuration in devices is done via communication and explained under the title of "Tariff Configuration"

### Serial Communication Settings

The devices have an optional RS485 serial communication interface. "Slave ID", "Baudrate", "Parity", "Stop Bit" and "Data Type" settings of devices with this interface are made under this tab.

The default values are as follows.

- Slave ID:1
- Baudrate:38400
- Parity: None
- Stop Bit: 1
- Data Type: Big-Endian (BE)

### Demand Settings

Under this tab, the demand calculation method and period are entered. The device has 3 different demand calculation methods.

**Sliding Method:** Demand values are calculated in blocks of time determined according to the set time. Time blocks are the value in seconds of demand time intervals set in minutes. In other words, the demand measurements of a device with a demand time of 15 minutes are updated with time blocks of each 15 seconds. The device updates the demand value at the end of the time interval.

**Rolling Method:** Demand values are calculated in adjusted lower time intervals. If the demand calculation method is selected as Rolling, "Sub-interval" should also be determined. The sub-interval must be equally divisible by the period. If a non-divisible sub-interval is set to the period, the sub-interval value is calculated as 1 minute. The device updates the demand value at the end of the time interval.

The default values are as follows.

- Method: Sliding
- Period: 15 min.
- Sub-interval: 1 min. (It is unimportant in demand calculation because its method is "Sliding")

### Pulse Settings

The pulse outputs are used to receive output according to the counted energy value or to assign alarms to the parameters on the "Instant Measurements" page. The devices have 2 optional pulse outputs.

These pulse outputs can be fixed or interchangeable depending on the model.

Constant pulse outputs only give output according to the "Total Import Active Energy" value measured in the device, giving 1 (1000imp/kWh) output per 1Wh. The active duration of the pulse outputs, which are fixed, is fixed and 100 ms.

The adjustable pulse outputs operate in 2 different modes: energy mode and alarm mode.

#### 1. Energy Mode

Pulse outputs in energy mode are used as energy indicators such as fixed pulse outputs and the energy parameter and value to be shown are adjustable. Adjustable values;

Pulse outputs are used to get output according to the energy value counted. The devices have 2 optional pulse outputs.

The 2nd pulse output, which is optionally available in the devices, is adjustable and the energy source desired to be pulsed is the 1st pulse output in the devices, and it gives 1 (1000imp / kWh) output for every 1Wh. The active duration of the fixed pulse outputs is constant and is 100 ms.

The 2nd pulse output, which is optionally available in the devices, is adjustable, and the energy source to be pulsed, the amount of energy to be counted for one pulse output and the pulse duration must be entered.

4 different selections can be made for "source". The source of the energy to be output should be selected here.

- Import Active Energy
- Export Active Energy
- Import Reactive Energy
- Export Reactive Energy

An integer from 1 to 9 must be entered for "Energy". It is multiplied by the parameter selected from the "Multiplier" section and it is determined how much energy will be counted for a pulse. The duration that the pulse will remain active is set with the "Time" parameter. For example,

Pulse 2 Source -> Import Active Energy

Pulse 2 Energy -> 5

Pulse 2 Multiplier -> MUL10 (means it will be multiplied by 10.)

Pulse 2 Time -> 1000 (its unit is milliseconds.)

Suppose the parameters are selected as above.

The device will give 1 pulse for  $5 \times 10 = 50$  Wh energy. The pulse will remain active for 1 second.

NOTE: By default, Pulse 2 output gives 1 (1000 imp/kVArh) output at 1VArh.

## 2. Alarm Mode

With this mode, the pulse outputs are used to assign alarms to the parameters shown in the instantaneous measurements menu.

- Voltage
- Current
- Frequency
- Active Power
- Reactive Power
- Apparent Power
- Power Factor

Limit values (High and Low), Delay, Hysteresis and Alarm Output can be set for each parameter above for which alarm assignment is desired.

For example, if the alarm parameters for the Voltage alarm are set as follows;

! Alarm configuration in the devices is made only through communication. Alarm configuration cannot be made on devices without communication interface (RS485).

High Voltage: 250 V  
 Low Voltage: 200 V  
 Voltage Delay: 5 (means 5 sec)  
 Voltage Hysteresis: 10 (means 10%)  
 Voltage Alarm Output: 1 (0: Off/ 1: 1. Output / 2: 2. Output)

If the measured voltage is above 250 V, after 5 seconds, the alarm will be activated and the alarm flag (1) will be active and the 1st digital output will be active. Since the hysteresis is set to 10%, the alarm condition disappears when the voltage drops below 225 V (250 x 0.9).



The "Alarm Output" configuration parameter in the alarm mode differs according to the hardware of the device. For example, "Alarm Output" parameter can be set as 0 (Off) or 2 (2nd Output) in devices with only 2nd pulse output adjustable.

#### Device Settings

Under this tab, the language and backlight status of the device are set. The device has 2 different language settings, Turkish and English.

The backlight, on the other hand, can be adjusted in 3 different options: always on (on), always off (off) and depending on time. If it is selected depending on the time, how long it will remain active (Time) should be selected.

#### Date&Time

It is the date and time setting section of the device. The 6 different parameters must be entered separately:

- Year
- Month
- Day
- Hour
- Minute
- Second

#### Network Settings

There are 2 different options in the devices as direct connection and current transformer connection. Under this tab, transformer ratios of current transformer connected products are entered. Also under this tab, it is selected to include CT-VT ratios in the index values shown in the "Measurements" menu.

By default, rates are included in the index calculation. (WITH RATIO) For example, let the mentioned parameters be as follows;

- Current transformer ratio (CTR)= 100
- Voltage transformer ratio (VTR)= 1
- Ratio= WITH RATIO
- Total Import Active Energy= 1000

If "Ratio" = WITHOUT RATIO" selected; it will be displayed as  
 Total Import Active Energy = 10 (1000/100) on the screen.

#### Güvenlik Ayarları



- 1) The "Ratio" parameter can be changed continuously. The energy value to be displayed will differ according to the selected option.
- 2) CT / VT ratios are not included in the pulse output calculations in the devices.

**Security Settings**

Password protection is set on the device under this tab.  
The default values are as follows:

- **Protection:** Off
- **Password:** 0000001

**Clear**

5 different parameters can be cleared under this tab.

**Settings:** Used to return to factory settings.

**Energy:** Used to clear energy values.

**Demand:** Demand data is cleared under this tab

**All:** Used for all parameters mentioned above.

**3.3 Date&Time**

The devices with a real time clock (RTC) have this menu. The date and time settings of the device are displayed under this menu.

**3.4 Info**

The information about the device is shown under this tab.

Device Info (INFO)	Order Number (ORDER NO)
	Serial Number (SERIAL NO)
	Firmware Version (FIRMWARE)
	Hardware Version (HARDWARE)
	Modbus Version (MODBUS VER)

**Order Number**

The order number for the device is displayed.

**Serial Number**

The serial number of the device is displayed.

**Firmware Version**

The firmware version of the device is displayed.

**Hardware Version**

The hardware version of the device is displayed.

**Modbus Version**

The Modbus version of the device is displayed.

**3.5 Login**

This is the section where the password is entered. When the password is entered successfully, the text "SUCCESS" appears on the screen.

**EMD2 Series**

---

**SECTION 4**  
TARIFF  
CONFIGURATION

Tariff and sub-tariff configurations in devices are made via communication.

There are 2 tariffs as T1 and T2 as an option, and there are 4 sub-tariffs as T1-1, T1-2, T1-3 and T1-4 under the T1 tariff as optional.

**! The values calculated under the T1 tariff are the sum of the T1-1, T1-2, T1-3 and T1-4 tariffs.**

If we give an example over Import Active Energy;

Suppose that T1-1 = 10 kWh

T1-2 = 15 kWh

T1-3 = 20 kWh

T1-4 = 25 kWh.

Then the value that will appear in the T1 tariff will be 70 kWh.

In order to change the tariff counted by the device (from T1 to T2 or vice versa), the change active tariff command must be sent via communication.

For 4-tariff products, sub-tariff changes can be made with 10 different settings depending on time. According to these 10 different settings, which tariff is set in which time zone, the counter of the newly adjusted tariff will be active from that time on. For example, if the following settings are made:

While the configuration and reading operations of the devices can be done via the device, the reading and configuration processes of the devices with RS485 communication interface are also performed via the user interface program "Klemsan Configuration Wizard" and/or various Modbus test interfaces.

Settings	Tariff	Start Time
#1	T1-1	00:00
#2	T1-2	02:00
#3	T1-3	04:00
#4	T1-4	05:00
#5	T1-2	08:30
#6	T1-4	09:00
#7	T1-1	11:00
#8	T1-2	15:00
#9	T1-4	19:30
#10	T1-3	22:00

The activity of tariffs will be as in the table below. In the table painted in red, T1 tariffs are active over time, but where there is a T2 tariff, T1 tariffs will not be active. In cases painted with green, the corresponding T1 tariffs are counted.

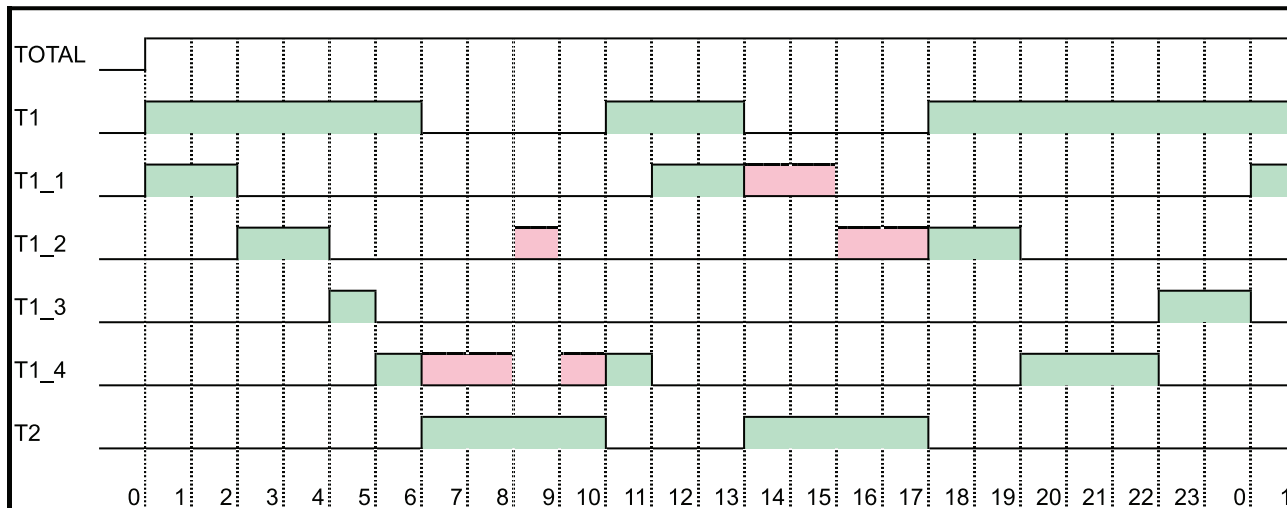

**EMD2 Series**

---

**SECTION 5**  
RS485  
COMMUNICATION

In order for the device to be configured via the Klemsan Configuration Wizard, the relevant file must be downloaded from the Klemsan web page. (Product page linking can be done.)

You can find the support document (KlemsanConfigurationWizard\_Yardıı) for the interface program here.

EMD2 series devices communicate using the “Modbus RTU” protocol, thanks to the optional RS485 interface on it. Supported functions are:

- Function 03H: This function reads the readable addresses in the Modbus table.
- Function 10H: This function writes the writable addresses in the Modbus table.

The Modbus tables below are for the products **580 -1M-V4CT** and **580 -1M-V3**.

Item	Address	Variable	Type	Read / Write	Function	Description	Default
1	0	Gerilim	float	r	03H		
2	2	Akım	float	r	03H		
3	4	Aktif Güç	float	r	03H		
4	6	Reaktif Güç	float	r	03H		
5	8	Görünür Güç	float	r	03H		
6	10	Power Faktör	float	r	03H		
7	12	Frekans	float	r	03H		
8	14	THDV	float	r	03H		
9	16	THDI	float	r	03H		
10	18	Ø	float	r	03H		
11	20	Gerilim Harmoniği 1	float	r	03H		
12	22	Gerilim Harmoniği 3	float	r	03H		
13	24	Gerilim Harmoniği 5	float	r	03H		
14	26	Gerilim Harmoniği 7	float	r	03H		
15	28	Gerilim Harmoniği 9	float	r	03H		
16	30	Gerilim Harmoniği 11	float	r	03H		
17	32	Gerilim Harmoniği 13	float	r	03H		
18	34	Gerilim Harmoniği 15	float	r	03H		
19	36	Gerilim Harmoniği 17	float	r	03H		
20	38	Gerilim Harmoniği 19	float	r	03H		
21	40	Gerilim Harmoniği 21	float	r	03H		
22	42	Gerilim Harmoniği 23	float	r	03H		
23	44	Gerilim Harmoniği 25	float	r	03H		
24	46	Gerilim Harmoniği 27	float	r	03H		
25	48	Gerilim Harmoniği 29	float	r	03H		
26	50	Gerilim Harmoniği 31	float	r	03H		
27	52	Akım Harmoniği 1	float	r	03H		
28	54	Akım Harmoniği 3	float	r	03H		
29	56	Akım Harmoniği 5	float	r	03H		
30	58	Akım Harmoniği 7	float	r	03H		
31	60	Akım Harmoniği 9	float	r	03H		
32	62	Akım Harmoniği 11	float	r	03H		
33	64	Akım Harmoniği 13	float	r	03H		
34	66	Akım Harmoniği 15	float	r	03H		
35	68	Akım Harmoniği 17	float	r	03H		
36	70	Akım Harmoniği 19	float	r	03H		
37	72	Akım Harmoniği 21	float	r	03H		
38	74	Akım Harmoniği 23	float	r	03H		
39	76	Akım Harmoniği 25	float	r	03H		
40	78	Akım Harmoniği 27	float	r	03H		
41	80	Akım Harmoniği 29	float	r	03H		
42	82	Akım Harmoniği 31	float	r	03H		
43	84	Minimum Gerilim	float	r	03H		
44	86	Maksimum Gerilim	float	r	03H		
45	88	Minimum Akım	float	r	03H		
46	90	Maksimum Akım	float	r	03H		
47	92	Minimum Import Aktif Güç	float	r	03H		
48	94	Maksimum Import Aktif Güç	float	r	03H		
49	96	Minimum Export Aktif Güç	float	r	03H		

Item	Address	Variable	Type	Read / Write	Function	Description	Default
50	98	Maksimum Export Aktif Güç	float	r	03H		
51	100	Minimum Import Reaktif Güç	float	r	03H		
52	102	Maksimum Import Reaktif Güç	float	r	03H		
53	104	Minimum Export Reaktif Güç	float	r	03H		
54	106	Maksimum Export Reaktif Güç	float	r	03H		
55	108	Minimum Görünür Güç	float	r	03H		
56	110	Maksimum Görünür Güç	float	r	03H		
57	112	Minimum Import Güç Faktörü	float	r	03H		
58	114	Maksimum Import Güç Faktörü	float	r	03H		
59	116	Minimum Export Güç Faktörü	float	r	03H		
60	118	Maksimum Export Güç Faktörü	float	r	03H		
61	120	Minimum Frekans	float	r	03H		
62	122	Maksimum Frekans	float	r	03H		
63	300	Toplam İmport Aktif Enerji	double	r	03H		
64	304	T1 İmport Aktif Enerji	double	r	03H		
65	308	T1-1 İmport Aktif Enerji	double	r	03H		
66	312	T1-2 İmport Aktif Enerji	double	r	03H		
67	316	T1-3 İmport Aktif Enerji	double	r	03H		
68	320	T1-4 İmport Aktif Enerji	double	r	03H		
69	324	T2 İmport Aktif Enerji	double	r	03H		
70	328	Toplam Eksport Aktif Enerji	double	r	03H		
71	332	T1 Eksport Aktif Enerji	double	r	03H		
72	336	T1-1 Eksport Aktif Enerji	double	r	03H		
73	340	T1-2 Eksport Aktif Enerji	double	r	03H		
74	344	T1-3 Eksport Aktif Enerji	double	r	03H		
75	348	T1-4 Eksport Aktif Enerji	double	r	03H		
76	352	T2 Eksport Aktif Enerji	double	r	03H		
77	356	Toplam İmport Reaktif Enerji	double	r	03H		
78	360	T1 İmport Reaktif Enerji	double	r	03H		
79	364	T1-1 İmport Reaktif Enerji	double	r	03H		
80	368	T1-2 İmport Reaktif Enerji	double	r	03H		
81	372	T1-3 İmport Reaktif Enerji	double	r	03H		
82	376	T1-4 İmport Reaktif Enerji	double	r	03H		
83	380	T2 İmport Reaktif Enerji	double	r	03H		
84	384	Toplam Eksport Reaktif Enerji	double	r	03H		
85	388	T1 Eksport Reaktif Enerji	double	r	03H		
86	392	T1-1 Eksport Reaktif Enerji	double	r	03H		
87	396	T1-2 Eksport Reaktif Enerji	double	r	03H		
88	400	T1-3 Eksport Reaktif Enerji	double	r	03H		
89	404	T1-4 Eksport Reaktif Enerji	double	r	03H		
90	408	T2 Eksport Reaktif Enerji	double	r	03H		
91	500	Akım Demand	float	r	03H		
92	502	İmport Aktif Güç Demandı	float	r	03H		
93	504	Export Aktif Güç Demandı	float	r	03H		
94	506	İmport Reaktif Güç Demand	float	r	03H		
95	508	Export Reaktif Güç Demand	float	r	03H		
96	510	Görünür Güç Demand	float	r	03H		
97	512	Max Akım Demandı	float	r	03H		
98	514	Max İmport Aktif Güç Demandı	float	r	03H		

Item	Address	Variable	Type	Read / Write	Function	Description	Default
99	516	Max Export Aktif Güç Demandı	float	r	03H		
100	518	Max Import Reaktif Güç Demandı	float	r	03H		
101	520	Max Export Reaktif Güç Demandı	float	r	03H		
102	522	Max Görünür Güç Demandı	float	r	03H		
103	524	Akım Tahmini Demandı	float	r	03H		
104	526	Import Aktif Güç Tahmini Demandı	float	r	03H		
105	528	Export Aktif Güç Tahmini Demandı	float	r	03H		
106	530	Import Reaktif Güç Tahmini Demandı	float	r	03H		
107	532	Export Reaktif Güç Tahmini Demandı	float	r	03H		
108	534	Görünür Güç Tahmini Demandı	float	r	03H		
109	600	Gün	uint32_t	r / w	03H / 10H	01-31	
110	602	Ay	uint32_t	r / w	03H / 10H	01-12	
111	604	Yıl	uint32_t	r / w	03H / 10H	00-99	
112	606	Saat	uint32_t	r / w	03H / 10H	00-23	
113	608	Dakika	uint32_t	r / w	03H / 10H	00-59	
114	610	Saniye	uint32_t	r / w	03H / 10H	00-59	
115	700	Slave ID	uint32_t	r / w	03H / 10H	1-247	1
116	702	Baudrate	uint32_t	r / w	03H / 10H	0 = 1200 1 = 2400 2 = 4800 3 = 9600 4 = 19200 5 = 38400 6 = 57600 7 = 115200"	5
117	704	Parite	uint32_t	r / w	03H / 10H	0 = None 1 = Tek 2 = ift	0
118	706	Stopbit	uint32_t	r / w	03H / 10H	0 = Stop Bit 1 1 = Stop Bit 2	0
119	708	Endian	uint32_t	r / w	03H / 10H	0 = Big Endian 1 = Little Endian 2 = Big Endian Byte Swap 3 = Little Endian Byte Swap	1
120	710	Demand Metodu	uint32_t	r / w	03H / 10H	0 = Fixed 1 = Sliding 2 = Rolling	1
121	712	Demand Periyodu	uint32_t	r / w	03H / 10H	1 - 60 sec.	15
122	714	Alt Aralık	uint32_t	r / w	03H / 10H	1 - 60 sec.	1
123	716	Pals 1 Kaynak	uint32_t	r / w	03H	0 = Kapalı 1 = Import Aktif 2 = Export Aktif 3 = Import Reaktif 4 = Export Reaktif	1
124	718	Pals 1 Mod	uint32_t	r / w	03H	0 = Energy 1 = Alarm	0
125	720	Pals 1 Enerji	uint32_t	r / w	03H	1-9	1
126	722	Pals 1 Çarpanı	uint32_t	r / w	03H	0 = 1 / 1000 1 = 1 / 100 2 = 1 / 10 3 = 1 4 = 10 5 = 100 6 = 1000	3

Item	Address	Variable	Type	Read / Write	Function	Description	Default
127	724	Pals 1 Zaman	uint32_t	r / w	03H	50-2500 msec.	100
128	726	Pals 2 Kaynak	uint32_t	r / w*	03H / 10H	0 = Kapalı 1 = Import Aktif 2 = Export Aktif 3 = Import Reaktif 4 = Export Reaktif	3
129	728	Pals 2 Mod	uint32_t	r / w*	03H / 10H	0 = Energy 1 = Alarm	0
130	730	Pals 2 Enerji	uint32_t	r / w*	03H / 10H	1-9	1
131	732	Pals 2 Çarpanı	uint32_t	r / w*	03H / 10H	0 = 1 / 1000 1 = 1 / 100 2 = 1 / 10 3 = 1 4 = 10 5 = 100 6 = 1000	3
132	734	Pals 2 Zaman	uint32_t	r / w*	03H / 10H	50-2500 msec.	100
142	754	Düşük Gerilim Limiti	float	r / w	03H / 10H	0 - 10000	200
143	756	Yüksek Gerilim Limiti	float	r / w	03H / 10H	0 - 10000	250
144	758	Gerilim Gecikme	uint32_t	r / w	03H / 10H	1 - 600 sn	5
145	760	Gerilim Histeresiz	float	r / w	03H / 10H	0 - 20	2
146	762	Gerilim Alarm Çıkışı	uint32_t	r / w	03H / 10H	0 = Kapalı 1 = 1. Çıkış 2 = 2. Çıkış	0
147	764	Düşük Akım Limiti	float	r / w	03H / 10H	0 - 10000	1
148	766	Yüksek Akım Limiti	float	r / w	03H / 10H	0 - 10000	6
149	768	Akım Gecikme	uint32_t	r / w	03H / 10H	1 - 600 sn	5
150	770	Akım Histeresiz	float	r / w	03H / 10H	0 - 20	5
151	772	Akım Alarm Çıkışı	uint32_t	r / w	03H / 10H	0 = Kapalı 1 = 1. Çıkış 2 = 2. Çıkış	0
152	774	Düşük Aktif Güç Limiti	float	r / w	03H / 10H	0 - 10000	0
153	776	Yüksek Aktif Güç Limiti	float	r / w	03H / 10H	0 - 10000	1500
154	778	Aktif Güç Gecikme	uint32_t	r / w	03H / 10H	1 - 600 sn	5
155	780	Aktif Güç Histeresiz	float	r / w	03H / 10H	0 - 20	5
156	782	Aktif Güç Alarm Çıkışı	uint32_t	r / w	03H / 10H	0 = Kapalı 1 = 1. Çıkış 2 = 2. Çıkış	5
157	784	Düşük Reaktif Güç Limiti	float	r / w	03H / 10H	0 - 100000	0
158	786	Yüksek Reaktif Güç Limiti	float	r / w	03H / 10H	0 - 100000	250
159	788	Reaktif Güç Gecikme	uint32_t	r / w	03H / 10H	1 - 600 sn	5
160	790	Reaktif Güç Histeresiz	float	r / w	03H / 10H	0 - 20	5
161	792	Reaktif Güç Alarm Çıkışı	uint32_t	r / w	03H / 10H	0 = Kapalı 1 = 1. Çıkış 2 = 2. Çıkış	0
162	794	Düşük Görünür Güç Limiti	float	r / w	03H / 10H	0 - 100000	0
163	796	Yüksek Görünür Güç Limiti	float	r / w	03H / 10H	0 - 100000	1500
164	798	Görünür Güç Gecikme	uint32_t	r / w	03H / 10H	1 - 600 sn	5
165	800	Görünür Güç Histeresiz	float	r / w	03H / 10H	0 - 20	5
166	802	Görünür Güç Alarm Çıkışı	uint32_t	r / w	03H / 10H	0 = Kapalı 1 = 1. Çıkış 2 = 2. Çıkış	0
167	804	Düşük Güç Faktörü Limiti	float	r / w	03H / 10H	0 - 1	0
168	806	Yüksek Güç Faktörü Limiti	float	r / w	03H / 10H	0 - 1	1
169	808	Güç Faktörü Gecikme	uint32_t	r / w	03H / 10H	1 - 600	5
170	810	Güç Faktörü Histeresiz	float	r / w	03H / 10H	0 - 20	5

Item	Address	Variable	Type	Read / Write	Function	Description	Default
171	812	Güç Faktörü Alarm Çıkışı	uint32_t	r / w	03H / 10H	0 = Kapalı 1 = 1. Çıkış 2 = 2. Çıkış	0
172	814	Düşük Frekans Limiti	float	r / w	03H / 10H	45-65	45
173	816	Yüksek Frekans Limiti	float	r / w	03H / 10H	45-65	60
174	818	Frekans Gecikme	uint32_t	r / w	03H / 10H	1 - 600	5
175	820	Frekans Histeresiz	float	r / w	03H / 10H	0 - 20	5
176	822	Frekans Alarm Çıkışı	uint32_t	r / w	03H / 10H	0 = Kapalı 1 = 1. Çıkış 2 = 2. Çıkış	0
177	836	Tarife Ayarı 1	uint32_t	r / w	03H / 10H	1= T1-1 2= T1-2 3= T1-3 4= T1-4	1
178	838	Saat 1	uint32_t	r / w	03H / 10H	00-24	0
179	840	Dakika 1	uint32_t	r / w	03H / 10H	00-59	0
180	842	Tarife Ayarı 2	uint32_t	r / w	03H / 10H	0= Pasif 1= T1-1 2= T1-2 3= T1-3 4= T1-4	0
181	844	Saat 2	uint32_t	r / w	03H / 10H	00-24	0
182	846	Dakika 2	uint32_t	r / w	03H / 10H	00-59	0
183	848	Tarife Ayarı 3	uint32_t	r / w	03H / 10H	0= Pasif 1= T1-1 2= T1-2 3= T1-3 4= T1-4	0
184	850	Saat 3	uint32_t	r / w	03H / 10H	00-24	0
185	852	Dakika 3	uint32_t	r / w	03H / 10H	00-59	0
186	854	Tarife Ayarı 4	uint32_t	r / w	03H / 10H	0= Pasif 1= T1-1 2= T1-2 3= T1-3 4= T1-4	0
187	856	Saat 4	uint32_t	r / w	03H / 10H	00-24	0
188	858	Dakika 4	uint32_t	r / w	03H / 10H	00-59	0
189	860	Tarife Ayarı 5	uint32_t	r / w	03H / 10H	0= Pasif 1= T1-1 2= T1-2 3= T1-3 4= T1-4	0
190	862	Saat 5	uint32_t	r / w	03H / 10H		0
191	864	Dakika 5	uint32_t	r / w	03H / 10H		0
192	866	Tarife Ayarı 6	uint32_t	r / w	03H / 10H	0= Pasif 1= T1-1 2= T1-2 3= T1-3 4= T1-4	0
193	868	Saat 6	uint32_t	r / w	03H / 10H	00-24	0
194	870	Dakika 6	uint32_t	r / w	03H / 10H	00-59	0
195	872	Tarife Ayarı 7	uint32_t	r / w	03H / 10H	0= Pasif 1= T1-1 2= T1-2 3= T1-3 4= T1-4	0
196	874	Saat 7	uint32_t	r / w	03H / 10H	00-24	0
197	876	Dakika 7	uint32_t	r / w	03H / 10H	00-59	0

Item	Address	Variable	Type	Read / Write	Function	Description	Default
198	878	Tarife Ayarı 8	uint32_t	r / w	03H / 10H	0= Pasif 1= T1-1 2= T1-2 3= T1-3 4= T1-4	0
199	880	Saat 8	uint32_t	r / w	03H / 10H	00-24	0
200	882	Dakika 8	uint32_t	r / w	03H / 10H	00-59	0
201	884	Tarife Ayarı 9	uint32_t	r / w	03H / 10H	0= Pasif 1= T1-1 2= T1-2 3= T1-3 4= T1-4	0
202	886	Saat 9	uint32_t	r / w	03H / 10H	00-24	0
203	888	Dakika 9	uint32_t	r / w	03H / 10H	00-59	0
204	890	Tarife Ayarı 10	uint32_t	r / w	03H / 10H	0= Pasif 1= T1-1 2= T1-2 3= T1-3 4= T1-4	0
205	892	Saat 10	uint32_t	r / w	03H / 10H	00-24	0
206	894	Dakika 10	uint32_t	r / w	03H / 10H	00-59	0

The alarm Flags are as follows:

Alarm Status Flags																
31	30	29	28	27	26	25	24	23	22	21	20	19	18	17	16	Maximum
									F	PF	S	Q	P	I	V(L-N)	
15	14	13	12	11	10	9	8	7	6	5	4	3	2	1	0	Minimum
									F	PF	S	Q	P	I	V(L-N)	

Bit	Description
0	V(L-N) Low phase-neutral Voltage Alarm
1	I – Low Current Alarm
2	P – Low Active Power Alarm
3	Q – Low Reactive Power Alarm
4	S – Low Apparent Power Alarm
5	PF – Low Power Factor Alarm
6	F – Low Frequency Alarm
16	V(L-N) High phase-neutral Voltage Alarm
17	I - High Current Alarm
18	P - High Active Power Alarm
19	Q – High Reactive Power Alarm
20	S - High Apparent Power Alarm
21	PF - High Power Factor Alarm
22	F - High Frequency Alarm

Address	Function	Type	Read (r) / Write (w)	Description
2000	6H	uint16_t	wo	Location Address
<b>Value</b>		<b>Command</b>		<b>Description</b>
100		Save Configuration		
110		Return to Default		
120		Restart		
200		Clear Demand Data		
300		Clear Min / Max Data		
400		Clear Energy Data		

Address	Function	Type	Read(r) / Write (w)	Description
2000	6H	uint16_t	wo	Location Address
<b>Value</b>		<b>Command</b>		<b>Description</b>
220		Change Active Tariff		

**!** In order to activate the writable addresses of the device, the device's password must be entered into the following addresses. Otherwise, the device cannot be configured.

Item	Address	Variable	Type	Read / Write	Function
1	6000	Password 0-2	3 byte char	r/w	03H/10H
2	6002	Password 3-7	4 byte char	r/w	03H/10H

The default password for the device is 0000001. The ASCII equivalent of each character must be entered in the relevant addresses as hex. For example, for a device with a password 1234567, a data entry should be made to the relevant registers as follows.

Address	Value (hex)	Value (dec)
6000	0x0037	'NULL' '7'
6001	0x3635	6' '5'
6002	0x3433	5' '3'
6003	0x3231	2' '1'

The Modbus tables below are for the product **180-1M-V2**.

Item	Address	Variable	Type	Read / Write	Function	Description	Default
1	0	Gerilim	float	r	03H		
2	2	Akım	float	r	03H		
3	4	Aktif Güç	float	r	03H		
4	6	Reaktif Güç	float	r	03H		
5	8	Görünür Güç	float	r	03H		
6	10	Power Faktör	float	r	03H		
7	12	Frekans	float	r	03H		
8	14	THDV	float	r	03H		
9	16	THDI	float	r	03H		
10	18	Ø	float	r	03H		
11	20	Gerilim Harmoniği 1	float	r	03H		
12	22	Gerilim Harmoniği 3	float	r	03H		
13	24	Gerilim Harmoniği 5	float	r	03H		
14	26	Gerilim Harmoniği 7	float	r	03H		
15	28	Gerilim Harmoniği 9	float	r	03H		
16	30	Gerilim Harmoniği 11	float	r	03H		
17	32	Gerilim Harmoniği 13	float	r	03H		
18	34	Gerilim Harmoniği 15	float	r	03H		
19	36	Gerilim Harmoniği 17	float	r	03H		
20	38	Gerilim Harmoniği 19	float	r	03H		
21	40	Gerilim Harmoniği 21	float	r	03H		
22	42	Gerilim Harmoniği 23	float	r	03H		
23	44	Gerilim Harmoniği 25	float	r	03H		
24	46	Gerilim Harmoniği 27	float	r	03H		
25	48	Gerilim Harmoniği 29	float	r	03H		
26	50	Gerilim Harmoniği 31	float	r	03H		
27	52	Akım Harmoniği 1	float	r	03H		
28	54	Akım Harmoniği 3	float	r	03H		
29	56	Akım Harmoniği 5	float	r	03H		
30	58	Akım Harmoniği 7	float	r	03H		
31	60	Akım Harmoniği 9	float	r	03H		
32	62	Akım Harmoniği 11	float	r	03H		
33	64	Akım Harmoniği 13	float	r	03H		
34	66	Akım Harmoniği 15	float	r	03H		
35	68	Akım Harmoniği 17	float	r	03H		
36	70	Akım Harmoniği 19	float	r	03H		
37	72	Akım Harmoniği 21	float	r	03H		
38	74	Akım Harmoniği 23	float	r	03H		
39	76	Akım Harmoniği 25	float	r	03H		
40	78	Akım Harmoniği 27	float	r	03H		
41	80	Akım Harmoniği 29	float	r	03H		
42	82	Akım Harmoniği 31	float	r	03H		
43	84	Minimum Gerilim	float	r	03H		
44	86	Maksimum Gerilim	float	r	03H		
45	88	Minimum Akım	float	r	03H		
46	90	Maksimum Akım	float	r	03H		
47	92	Minimum Import Aktif Güç	float	r	03H		
48	94	Maksimum Import Aktif Güç	float	r	03H		
49	96	Minimum Export Aktif Güç	float	r	03H		

Item	Address	Variable	Type	Read / Write	Function	Description	Default
50	98	Maksimum Export Aktif Güç	float	r	03H		
51	100	Minimum Import Reaktif Güç	float	r	03H		
52	102	Maksimum Import Reaktif Güç	float	r	03H		
53	104	Minimum Export Reaktif Güç	float	r	03H		
54	106	Maksimum Export Reaktif Güç	float	r	03H		
55	108	Minimum Görünür Güç	float	r	03H		
56	110	Maksimum Görünür Güç	float	r	03H		
57	112	Minimum Import Güç Faktörü	float	r	03H		
58	114	Maksimum Import Güç Faktörü	float	r	03H		
59	116	Minimum Export Güç Faktörü	float	r	03H		
60	118	Maksimum Export Güç Faktörü	float	r	03H		
61	120	Minimum Frekans	float	r	03H		
62	122	Maksimum Frekans	float	r	03H		
63	300	Toplam İmport Aktif Enerji	double	r	03H		
64	304	T1 İmport Aktif Enerji	double	r	03H		
65	308	T2 İmport Aktif Enerji	double	r	03H		
66	312	Toplam Eksport Aktif Enerji	double	r	03H		
67	316	T1 Eksport Aktif Enerji	double	r	03H		
68	320	T2 Eksport Aktif Enerji	double	r	03H		
69	324	Toplam İmport Reaktif Enerji	double	r	03H		
70	328	T1 İmport Reaktif Enerji	double	r	03H		
71	332	T2 İmport Reaktif Enerji	double	r	03H		
72	336	Toplam Eksport Reaktif Enerji	double	r	03H		
73	340	T1 Eksport Reaktif Enerji	double	r	03H		
74	344	T2 Eksport Reaktif Enerji	double	r	03H		
75	500	Akım Demand	float	r	03H		
76	502	İmport Aktif Güç Demandı	float	r	03H		
77	504	Export Aktif Güç Demandı	float	r	03H		
78	506	İmport Reaktif Güç Demand	float	r	03H		
79	508	Export Reaktif Güç Demand	float	r	03H		
80	510	Görünür Güç Demand	float	r	03H		
81	512	Max. Akım Demand	float	r	03H		
82	514	Max. İmport Aktif Güç Demandı	float	r	03H		
83	516	Max. Export Aktif Güç Demandı	float	r	03H		
84	518	Max. İmport Reaktif Güç Demand	float	r	03H		
85	520	Max. Export Reaktif Güç Demand	float	r	03H		
86	522	Max. Görünür Güç Demand	float	r	03H		
87	700	Slave ID	uint32_t	r / w	03H / 10H	1-247	1
88	702	Baudrate	uint32_t	r / w	03H / 10H	0 = 1200 1 = 2400 2 = 4800 3 = 9600 4 = 19200 5 = 38400 6 = 57600 7 = 115200	5
89	704	Parite	uint32_t	r / w	03H / 10H	0 = None 1 = Tek 2 = Çift	0
90	706	Stopbit	uint32_t	r / w	03H / 10H	0 = Stop Bit 1 1 = Stop Bit 2	0

Item	Address	Variable	Type	Read / Write	Function	Description	Default
91	708	Endian	uint32_t	r / w	03H / 10H	0 = Big Endian 1 = Little Endian 2 = Big Endian Byte Swap 3 = Little Endian Byte Swap	1
92	710	Demand Metodu	uint32_t	r / w	03H / 10H	0 = Fixed 1 = Sliding 2 = Rolling	1
93	712	Demand Periyodu	uint32_t	r / w	03H / 10H	1 - 60 sec.	15
94	714	Alt Aralık	uint32_t	r / w	03H / 10H	1 - 60 sec.	1
102	754	Düşük Gerilim Limiti	uint32_t	r / w	03H / 10H	0 - 10000	200
103	756	Yüksek Gerilim Limiti	uint32_t	r / w	03H / 10H	0 - 10000	250
104	758	Gerilim Gecikme	uint32_t	r / w	03H / 10H	1 - 600 sn	5
105	760	Gerilim Histeresiz	float	r / w	03H / 10H	0 - 20	2
106	762	Düşük Akım Limiti	float	r / w	03H / 10H	0 - 10000	1
107	764	Yüksek Akım Limiti	float	r / w	03H / 10H	0 - 10000	6
108	766	Akım Gecikme	uint32_t	r / w	03H / 10H	1 - 600 sn	5
109	768	Akım Histeresiz	float	r / w	03H / 10H	0 - 20	5
110	770	Düşük Aktif Güç Limiti	float	r / w	03H / 10H	0 - 10000	0
111	772	Yüksek Aktif Güç Limiti	float	r / w	03H / 10H	0 - 10000	1500
112	774	Aktif Güç Gecikme	uint32_t	r / w	03H / 10H	1 - 600 sn	5
113	776	Aktif Güç Histeresiz	float	r / w	03H / 10H	0 - 20	5
114	778	Düşük Reaktif Güç Limiti	float	r / w	03H / 10H	0 - 100000	0
115	780	Yüksek Reaktif Güç Limiti	float	r / w	03H / 10H	0 - 100000	250
116	782	Reaktif Güç Gecikme	uint32_t	r / w	03H / 10H	1 - 600 sn	5
117	784	Reaktif Güç Histeresiz	float	r / w	03H / 10H	0 - 20	5
118	786	Düşük Görünür Güç Limiti	float	r / w	03H / 10H	0 - 100000	0
119	788	Yüksek Görünür Güç Limiti	float	r / w	03H / 10H	0 - 100000	1500
120	790	Görünür Güç Gecikme	uint32_t	r / w	03H / 10H	1 - 600 sn	5
121	792	Görünür Güç Histeresiz	float	r / w	03H / 10H	0 - 20	5
122	794	Düşük Güç Faktörü Limiti	float	r / w	03H / 10H	0 - 1	0
123	796	Yüksek Güç Faktörü Limiti	float	r / w	03H / 10H	0 - 1	1
124	798	Güç Faktörü Gecikme	uint32_t	r / w	03H / 10H	1 - 600 sn	5
125	800	Güç Faktörü Histeresiz	float	r / w	03H / 10H	0 - 20	5
126	802	Düşük Frekans Limiti	float	r / w	03H / 10H	45-65	45
127	804	Yüksek Frekans Limiti	float	r / w	03H / 10H	45-65	60
128	806	Frekans Gecikme	uint32_t	r / w	03H / 10H	1 - 600 sn	5
129	808	Frekans Histeresiz	float	r / w	03H / 10H	0 - 20	5

The Alarm Flags are as follows:

Alarm Status Flags																
31	30	29	28	27	26	25	24	23	22	21	20	19	18	17	16	Maximum
									F	PF	S	Q	P	I	V(L-N)	
15	14	13	12	11	10	9	8	7	6	5	4	3	2	1	0	Minimum
									F	PF	S	Q	P	I	V(L-N)	

Bit	Description
0	V(L-N) Low phase-neutral Voltage Alarm
1	I – Low Current Alarm
2	P – Low Active Power Alarm
3	Q – Low Reactive Power Alarm
4	S – Low Apparent Power Alarm
5	PF – Low Power Factor Alarm
6	F – Low Frequency Alarm
16	V(L-N) High phase-neutral Voltage Alarm
17	I - High Current Alarm
18	P - High Active Power Alarm
19	Q – High Reactive Power Alarm
20	S - High Apparent Power Alarm
21	PF - High Power Factor Alarm
22	F - High Frequency Alarm

Address	Function	Type	Read (r) / Write (w)	Description
2000	6H	uint16_t	wo	Location Address
<b>Value</b>		<b>Command</b>		<b>Description</b>
100		Save Configuration		
110		Return to Default		
120		Restart		
200		Clear Demand Data		
300		Clear Min / Max Data		
400		Clear Energy Data		

Address	Function	Type	Read(r) / Write (w)	Description
2000	6H	uint16_t	wo	Location Address
<b>Value</b>		<b>Command</b>		<b>Description</b>
220		Change Active Tariff		

- ! In order to activate the writable addresses of the device, the password of the device must be entered into the following addresses. Otherwise, the device cannot be configured.

Item	Address	Variable	Type	Read / Write	Function
1	6000	Password 0-2	3 byte char	r/w	03H/10H
2	6002	Password 3-7	4 byte char	r/w	03H/10H

The default password for the device is 0000001. The ASCII equivalent of each character must be entered in the relevant addresses as hex. For example, for a device with a password 1234567, a data entry should be made to the relevant registers as follows.

Address	Value (hex)	Value (dec)
6000	0x0037	'NULL' '7'
6001	0x3635	6' '5'
6002	0x3433	5' '3'
6003	0x3231	2' '1'

**EMD2 Series**

---

**SECTION 6**  
**TECHNICAL**  
**SPECIFICATIONS**

Technical Specifications	
<b>General Specifications</b>	
Supply Voltage	Via measurement inputs
Supply Voltage <sub>ei</sub> (CT Connection)	85 - 300 VAC/DC
Power Consumption (Direct Connection)	<2VA
Power Consumption (For External Supply)	0.97 VA & 0.47 W
<b>Current Measurement</b>	
Input Consumption	0.2VA
Starting Current (I <sub>st</sub> )	20mA
Minimum Current (I <sub>min</sub> )	0,25A (0,15A for Class C)
Transition Current (I <sub>tr</sub> )	0.5A
Reference Current (I <sub>ref</sub> )	5A
Maximum Current (I <sub>max</sub> )	80A
<b>Current Measurement</b>	
Input Consumption	0.2VA
Starting Current (I <sub>st</sub> )	10mA
Minimum Current (I <sub>min</sub> )	0,05A
Transition Current (I <sub>tr</sub> )	0.25A
Reference Current (I <sub>ref</sub> )	5A
Maximum Current (I <sub>max</sub> )	6A
<b>Voltage Measurement</b>	
Measurement Range	220-240 VAC / 100-120 VAC
Consumption	<3VA
<b>Frequency Measurement</b>	
Frequency Measurement	45-65 Hz
<b>Energy Measurement</b>	
Active Energy	Class C & Class B (EN 50470)
Reactive Energy	Class 2 (IEC 62053-23)
Resolution	1Wh & 1VArh
<b>Pulse Output</b>	
Type	Opto-isolated 5..27VDC
Switching Current	50mA
Isolation	5000Vrms optical isolation
Max. contact separation time	18μs
Max. contact engagement time	18μs
<b>Screen</b>	
Type	7-digit LCD with backlight
Refreshing Time	1 sec.
Display Backlight Activation Time	Adjustable 10 - 600 sec.
Active Energy	00000.00 - 9999999 MWh
Reactive Energy	00000.00 - 9999999 MVarh
<b>Communication</b>	
Interface	RS485 2 wires/half duplex
Protocol	Modbus, RTU mode
Baudrate	1200 - 115200
Isolation	2500Vrms
<b>Environmental Factors</b>	
Operating Temperature	-25°C to +55°C
Storage Temperature	-25°C to +70°C
Humidity	<80% non condensing
Assembly	Internal (box/cabinet)
<b>Device Casing</b>	
Sizes WxHxD (mm)	36 x 90 x 67,5
Assembly	DIN rail
Protection Class	Front IP51 - Casing IP20
Insulation Class	Class II

6.1 Dimensions

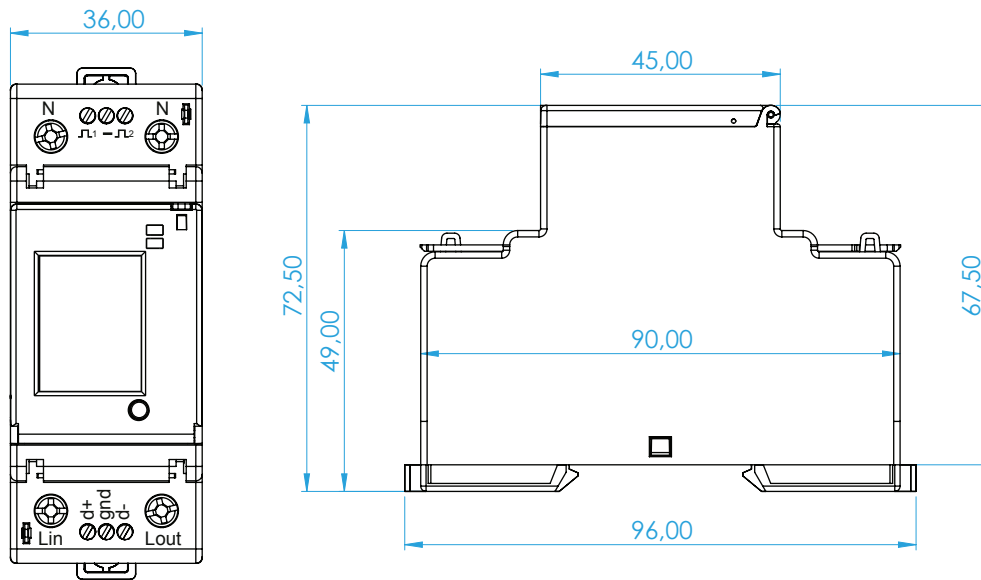

# Klemsan



Scan the QR code for all branches in TÜRKİYE and abroad.

## HEADQUARTERS - FACTORY

Kızılızüm Caddesi No:15  
35700 Kemalpaşa - İzmir

T: +90 232 877 08 00  
F: +90 232 877 08 06

info@klemsan.com.tr  
[www.klemsan.com.tr](http://www.klemsan.com.tr)

Revision No: 29032024